



HOLDEN

SANDMAN
Car club of Australia Inc

SERIES
FEATURES BOOK

PREPARED AND ISSUED BY
PRODUCT INFORMATION SECTION
ENGINEERING DEPARTMENT

HOLDEN 'HZ' FEATURES

INTRODUCTION

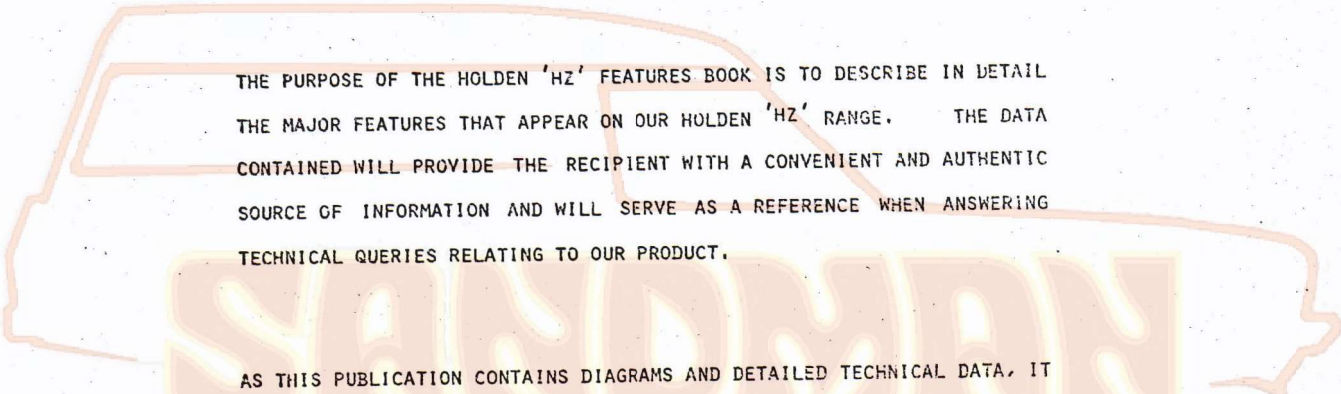

THE PURPOSE OF THE HOLDEN 'HZ' FEATURES BOOK IS TO DESCRIBE IN DETAIL THE MAJOR FEATURES THAT APPEAR ON OUR HOLDEN 'HZ' RANGE. THE DATA CONTAINED WILL PROVIDE THE RECIPIENT WITH A CONVENIENT AND AUTHENTIC SOURCE OF INFORMATION AND WILL SERVE AS A REFERENCE WHEN ANSWERING TECHNICAL QUERIES RELATING TO OUR PRODUCT.

AS THIS PUBLICATION CONTAINS DIAGRAMS AND DETAILED TECHNICAL DATA, IT IS IMPORTANT THAT IT BE TREATED AS STRICTLY CONFIDENTIAL AND HANDLED IN ACCORDANCE WITH COMPANY POLICY RELATING TO THE SECURITY OF ADVANCED INFORMATION.

IT IS REQUESTED THAT CHANGES IN CUSTODIANSHIP BE NOTIFIED PROMPTLY TO THE EXECUTIVE ENGINEER PROGRAM CONTROL, ENGINEERING DEPARTMENT, GENERAL MOTORS HOLDEN'S LIMITED.

F.R. Pound
F.R. POUND

Issued: APRIL, 1977

Revised:

HOLDEN 'HZ' FEATURES

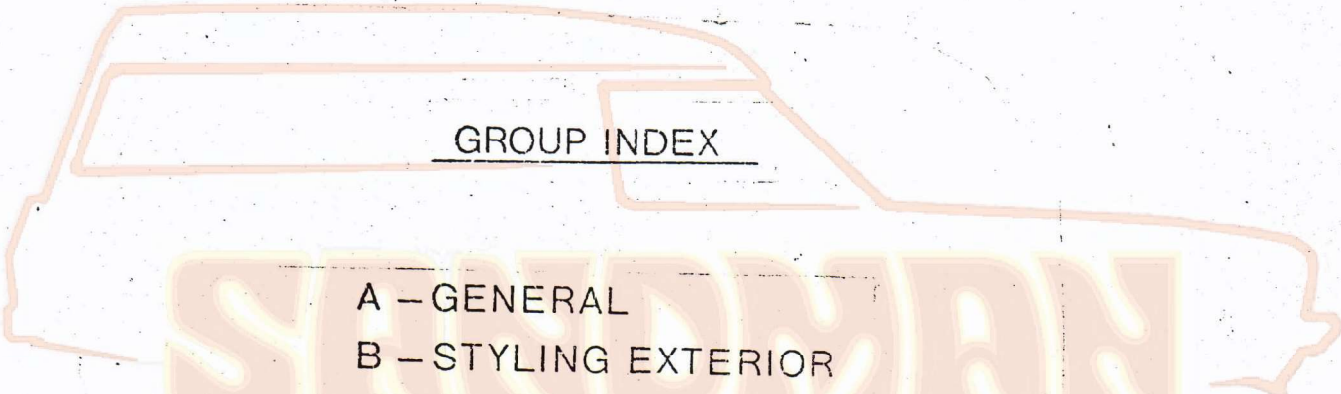

GROUP INDEX

A - GENERAL

B - STYLING EXTERIOR

C - STYLING INTERIOR

D - BODY

E - MECHANICAL

F - SPECIFICATIONS

SPINMAN
Car Club of Australia Inc

HOLDEN 'HZ' FEATURES

ALPHABETICAL INDEX

SUBJECT	PAGE NO.	SUBJECT	PAGE NO.
COVER SHEET		GENERATOR AND REGULATOR	F-35
GROUP INDEX		CLASS AREAS	F-11
ALPHABETICAL INDEX			
INTRODUCTION		HEATER	D-9
		HORNS	A-14 F-42
		HUB CAPS	B-31 TO B-33
AIR CLEANER	F-33	INSTRUMENTS / PANEL	E-11 C-17 TO C-20
AIRCONDITIONING	D-10, D-11	INTRODUCTION TO - SECTION B	B-1
ASH TRAYS	C-2 TO C-15	- SECTION C	C-1
ASSIST HANDLES	C-6 TO C-15	- SECTION D	D-1
ARMRESTS	C-2 TO C-15	- SECTION E	E-1
AXLE REAR	E-41 & 20		
BADGES	B-6 TO B-30	■ KEYS	E-8
BATTERY	F-42	LAMPS	E-11 E-12 F-42
BODY DIMENSIONS		LOCK - STEERING / IGNITION	E-8
INTERIOR	F-1 TO F-6	LOCKS - DOOR	D-4
EXTERIOR	F-7 TO F-10		
BRAKES	E-5 & F-24	MIRRORS	D-14 C-2 TO C-15
BRIEF DESCRIPTION OF 'HZ'	A-1	MODEL AVAILABILITY & BASE EQUIPMENT	A-2, A-3
BULBS	F-42	MOULDINGS	C-2 TO C-15
CAMSHAFT	F-32	PISTON AND PISTON PIN	F-30
CAPACITIES		POWER TRAIN COMBINATIONS	A-4 TO A-6
COOLING SYSTEM	F-35	PROPELLER SHAFTS	F-23
ENGINE OIL PAN	F-33		
FUEL TANK	F-39	RINGS - PISTON	F-30 F-31
OIL FILTER	F-33	SAFETY FEATURES	A-15
REAR AXLE	F-20	SERIAL NUMBERS	F-12 F-13
STEERING BOX	F-40	SEAT BELTS	D-12, D-13
TRANSMISSION		SEATING AND TRIM	C-2 TO C-15
AUTOMATIC	F-38	SPARK PLUGS	F-36
MANUAL	F-37	SKID HEADER PANEL	D-2
CAR PERFORMANCE DATA	F-27 F-28	STANDARD EQUIPMENT & OPTION SUMMARY	A-7 TO A-14
CARBURETTOR	F-33 F-34	STARTER MOTOR	F-36
CLUTCH	F-37	STEERING	E-9 F-40
COAT HOOKS	C-6 TO C-15	STEERING WHEELS	C-21 C-22
CONNECTING RODS	F-31	SUN VISORS	D-3
CONSOLE / SEAT SEPARATOR	C-6 TO C-15	SUSPENSION	E-3 F-17 TO F-19
COOLING SYSTEM	F-35	FRONT	E-3 F-17 TO F-19
CORROSION PROTECTION	D-4	REAR	E-4 F-20 TO F-22
CRANKCASE VENTILATION		TRANSMISSIONS	E-7 F-37 F-38
CRANKSHAFT	F-29	TRANSMISSION OUTPUT SPEEDS AUTOMATIC	F-38
CYLINDER BLOCK	F-29	TRUNK LUGGAGE CAPACITY	F-6
CYLINDER HEAD	F-29	TYRES	A-8 E-10 -41
DISTRIBUTOR	F-36	VALVE TRAIN	F-31 F-32
DIFFERENTIAL	F-20	VEHICLE PACKAGES	A-7 TO A-14
ENGINE	E-6 F-25 TO	WASHERS AND WIPERS	D-5
BASIC DATA	F-36 F-25 F-26	WEIGHTS - VEHICLE	F-14 F-15
EXHAUST SYSTEM	F-39	WEIGHTS - PRODUCTION OPTIONS	F-15 F-16
EMISSION CONTROL SYSTEMS	E-13 TO E-16	WHEELS	E-40 F-4
FLOOR COVERINGS	C-2 TO C-15	WHEEL ALIGNMENT	F-17
FLOW THRU VENTILATION	D-6 TO D-8	WHEEL COVERS	B-31 TO E-33
FLYWHEEL	F-30		
FRAME	E-2		
FUEL PUMP	F-33		
FUEL TANK	F-39		
FUSES	F-42		

HOLDEN 'HZ' FEATURES

GENERAL

INDEX TO SECTION "A"

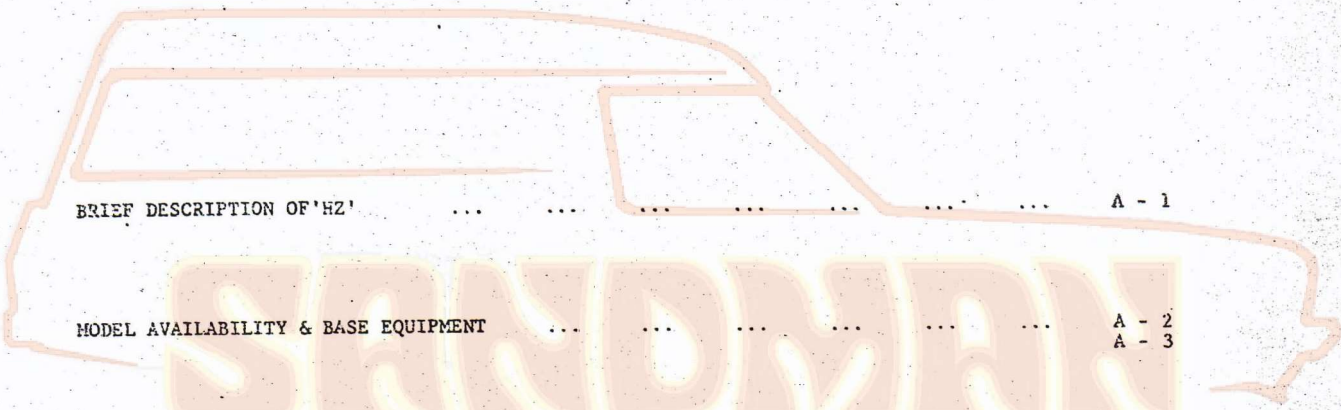

BRIEF DESCRIPTION OF 'HZ'	A - 1
MODEL AVAILABILITY & BASE EQUIPMENT	A - 2 A - 3
POWER TRAIN COMBINATIONS	A - 4 A - 5 A - 6
STANDARD EQUIPMENT & OPTION SUMMARY	A - 7 A - 8 A - 9 A - 10 A - 11 A - 12 A - 13 A - 14
SAFETY FEATURES	A - 15

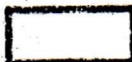

HOLDEN 'HZ' FEATURES

GENERAL

BRIEF DESCRIPTION OF 'HZ'

THE HOLDEN 'HZ' MODEL IS THE FOURTH REVISION TO THE 'W' BODY.
THE MOST NOTICEABLE VARIATIONS FROM 'HX' ARE :-

- * DELETION OF BELMONT MODELS,
KINGSWOOD PASSENGER MODELS UP-GRADED AND IDENTIFIED AS KINGSWOOD 'SL'.
- * IMPROVEMENTS TO RIDE AND HANDLING LEVELS.
- * INTRODUCTION OF 4 WHEEL DISC BRAKES ON 'GTS' AND STATESMAN.
- * MINOR APPEARANCE CHANGES (EXCEPT CHASSIS CAB).

THE BELMONT MODELS ARE DELETED FROM THE MODEL LINE-UP WHILE KINGSWOOD PASSENGER MODELS ARE UP-GRADED IN APPEARANCE AND EQUIPMENT LEVELS AND RE-DESIGNATED KINGSWOOD 'SL'. THE COMMERCIAL VEHICLE RANGE OF HOLDEN AND KINGSWOOD IS UNCHANGED EXCEPT FOR THE ADDITION OF A BENCH SEAT WITH CENTRE FOLDING ARMREST AS STANDARD EQUIPMENT.

THE INCREASING IMPORTANCE OF OPTIONAL 'VEHICLE PACKAGES' IS EMPHASIZED WITH THE AVAILABILITY OF A 'DELETE EQUIPMENT' OPTION ON KINGSWOOD 'SL' DESIGNATED AS 'KINGSWOOD'. THE 'KINGSWOOD' HAS A MUCH HIGHER EQUIPMENT LEVEL THAN THE 'HX' BELMONT AND ALMOST THE EQUIPMENT OF THE 'HX' KINGSWOOD.

AS THE KINGSWOOD, STATESMAN CALAIS AND THE IMPROVED CARRYOVER SANDMAN VEHICLES WILL BE AVAILABLE THROUGH THE MODEL LIFE AND ARE PRESENTED AS INDIVIDUAL MODELS THEY ARE NOW SHOWN IN VARIOUS SECTIONS OF THE FEATURES BOOK FOR THE FIRST TIME.

FOLLOWING PROGRESSIVE INTRODUCTION OF THE HIGHLY ACCEPTABLE CHANGES TO RIDE AND HANDLING ON THE TORANA MODELS THE NEW RIDE AND HANDLING DESIGN OBJECTIVES HAVE ALSO BEEN INTRODUCED ON ALL 'HZ' MODELS, THESE OBJECTIVES ARE - NEUTRAL HANDLING BEHAVIOUR, HIGH CORNERING FORCE CAPABILITY WITH REDUCED BODY ROLL, STIFFER BUT NO LESS COMFORTABLE RIDE, MAXIMUM STRAIGHT AHEAD STABILITY UNDER ALL LOAD AND DRIVING CONDITIONS, HIGH RESPONSE STEERING, OPTIMIZATION OF TYRE TRACTION AND SMOOTH RIDE UNDER FULL LOAD CONDITIONS.

BRAKE PERFORMANCE IS ALSO IMPROVED WITH THE INTRODUCTION OF 4 WHEEL DISC BRAKES AS STANDARD ON THE 'GTS' AND THE LONG WHEELBASE STATESMAN MODELS. REAR WHEEL DISC BRAKES ARE NOW AVAILABLE AS OPTIONAL EQUIPMENT TO PROVIDE A 4 WHEEL DISC BRAKE SYSTEM ON ALL OTHER MODELS EXCEPT CHASSIS CAB.

RADIAL PLY TYRES ON 6" WIDE WHEELS ARE FITTED ON ALL MODELS. STEEL BELTED RADIALS ARE STANDARD ON ALL PASSENGER MODELS AND CHASSIS CAB WHILE PANEL VAN, UTILITY AND KINGSWOOD (A9K) ARE FITTED WITH TEXTILE RADIALS.

▣ STATESMAN CALAIS MODEL IS CANCELLED
(PRODUCTION NOT COMMENCED)

Issued: APRIL, 1977 ▣ Revised: OCTOBER, 1977

HOLDEN 'HZ' FEATURES

GENERAL

MODEL AVAILABILITY AND BASE EQUIPMENT

BODY STYLE	MODEL		NO. OF DOORS	WB ins. (mm)	ENGINE	TRANSMISSION		AXLE RATIO : 1	TYRES	FRONT SEAT
	NUMBER	NAME				TYPE	SHIFT LOCATION			

AUSTRALIA AND EXPORT EXCLUDING GMNZ

SEDAN +	8WN69	KINGSWOOD SL	4	111.0 (2819)	3,3 L6 HC	3 SPEED MAN.	COLUMN	3.55	ER78S14	BUCKET
	8WP69	PREMIER			4,2 V8	AUTO. (TRIMATIC)	FLOOR (CONSOLE)	3.08		
	8WQ69	GTS			4 SPEED MAN.	3.36				
	8WS69	STATESMAN DEVILLE			5,0 V8	AUTO. (TURBO HYDRAMATIC)	3.08	FR78S14		
	8WT69	STATESMAN CAPRICE								
STATION WAGON	8WN35	KINGSWOOD SL	4	114.0 (2895)	3,3 L6 HC	3 SPEED MAN.	COLUMN	3.55	ER78S14	
	8WP35	PREMIER			4,2 V8	AUTO. (TRIMATIC)	FLOOR (CONSOLE)	3.08		
PANEL VAN	8WM70	HOLDEN	2	120.4 (3058)	3,3 L6 HC	3 SPEED MAN.	COLUMN	3.55	195SR14	CENTRE ARMREST BENCH
	8WN70	KINGSWOOD								
COUPE UTILITY	8WM80	HOLDEN	2	120.4 (3058)	3,3 L6 HC	3 SPEED MAN.	COLUMN	3.55	195R14LT	
	8WN80	KINGSWOOD								
CHASSIS CAB	8WM60	HOLDEN	2	120.4 (3058)						
PROD. OPT. VEHICLES	8WN69	KINGSWOOD	4	111.0 (2819)					195SR14	
	8WM70/80	SANDMAN	2	114.0 (2895)	4,2 V8 HC	4 SPEED MAN.	FLOOR (CONSOLE)		Ø	BUCKET

Ø SANDMAN TYRES SUBJECT TO GVM RESTRICTIONS

MAXIMUM GVM RATING - FR78S14

DERATED GVM 500 kg PAYLOAD - ER70H14

Issued: APRIL, 1977 Revised: JULY, 1978

HOLDEN 'HZ' FEATURES

GENERAL

MODEL AVAILABILITY AND BASE EQUIPMENT (CONTINUED)

BODY STYLE	MODEL		NO. OF DOORS	W.B. INS. (MM)	ENGINE TYPE	TRANSMISSION		AXLE RATIO : 1	TYRES	FRONT SEAT
	NUMBER	NAME				TYPE	SHIFT LOCATION			
GM - NEW ZEALAND										
SEDAN	8WN69	KINGSWOOD SL	4	111.0 (2819)	3300 L6 HC	AUTOMATIC TRIMATIC	COLUMN	3.08	ER78S14	CENTRE ARMREST BENCH
	8WP69	PREMIER			5.0L V8	AUTOMATIC TURBO HYDRAMATIC	FLOOR CONSOLE		ER70H14	BUCKET
	8WQ69	MONARO 'GTS'							FR78S14	
	8WS69	STATESMAN DEVILLE								
STATION WAGON	8WN35	KINGSWOOD SL	2	114.0 (2895)	3300 L6	AUTOMATIC TRIMATIC		3.08	ER78S14	
COUPE UTILITY	8WM80	HOLDEN			2850 L6 HC	3 SPEED MANUAL	COLUMN	3.90	F78L14	CENTRE ARMREST BENCH
	8WN80	KINGSWOOD			3300 L6 HC			3.55		
CHASSIS CAB	8WM60	HOLDEN		120.4 (3058)		4 SPEED MANUAL	FLOOR	4.44	F78-14	

Issued: APRIL, 1977

Revised:

HOLDEN 'HIZ' FEATURES

GENERAL

POWER TRAIN COMBINATIONS

PASSENGER

EFFECTIVE MODELS	ENGINE - TRANSMISSION	RECOMMENDED USAGE		
		COUNTRY/ HIGHWAY/ ECONOMY (HIGH RATIO)	CITY/ SUBURBAN/ BASE	TOWING/ PERFORMANCE (LOW RATIO)
SEDANS STATION WAGONS	3,3 - M15/M20	-	3.55	-
	3,3 - M22	-	3.55	-
	3,3 - M40	3.08	3.36	3.55
	4,2 - M15/M20	3.08	3.36	3.55
	4,2 - M21	3.36	3.55	-
	4,2 - M40	2.60	3.08	3.55
	5,0 - M21	3.08	3.36	3.55
	5,0 - M41	2.60	3.08	3.36

Issued: APRIL, 1977

Revised: JULY, 1978

HOLDEN 'HIZ' FEATURES

GENERAL INFORMATION

POWER TRAIN COMBINATIONS

COMMERCIAL

EFFECTIVE MODELS	ENGINE - TRANSMISSION	RECOMMENDED USAGE		
		COUNTRY/ HIGHWAY/ ECONOMY (HIGH RATIO)	CITY/ SUBURBAN/ BASE	TOWING/ PERFORMANCE (LOW RATIO)
UTILITY PANEL VAN	3,3 - M15/M20	-	3.55	-
	3,3 - M22	-	3.55	-
	3,3 - M40	3.08	3.55	-
	4,2 - M15/M20	3.08	3.36	3.55
	4,2 - M40	-	3.08	3.55
	5,0 - M21	3.08	3.36	3.55
	5,0 - M41	2.60	3.08	3.36
1 TON COMMERCIAL	3,3 - ALL	3.55	4.44	-
	4,2 - ALL	3.36	3.55	-

Issued: APRIL, 1977 ■ Revised: JULY, 1978

HOLDEN 'HZ' FEATURES

GENERAL

POWER TRAIN COMBINATIONS NEW ZEALAND PASSENGER AND COMMERCIAL

EFFECTIVE MODELS	ENGINE - TRANSMISSION	COUNTRY/ HIGHWAY/ ECONOMY (HIGH RATIO)	RECOMMENDED USAGE	
			CITY/ SUBURBAN/ BASE	TOWING/ PERFORMANCE (LOW RATIO)
UTILITY	2850 - M15	-	3.9	-
UTILITY KINGSWOOD SL	3300 - M15	-	3.55	-
KINGSWOOD SL PREMIER	3300 - M40	-	3.08	-
UTILITY	3300 - M40	-	3.36	-
MONARO GTS	5.0ℓ - M21	-	3.55	-
	5.0ℓ - M41	-	3.08	-
KINGSWOOD SL PREMIER KINGSWOOD UTILITY	5.0ℓ - M41	-	2.60	-
CHASSIS CAB	3300 - M15	3.55	4.44	-

Issued: APRIL, 1977

Revised:

HOLDEN 'HZ' FEATURES

GENERAL

GENERAL

STANDARD EQUIPMENT AND OPTION SUMMARY

THIS CHART SHOWS MAJOR ITEMS OF STANDARD EQUIPMENT AND OPTION VARIANCE BETWEEN MODELS FOR DOMESTIC (AUSTRALIA) PRODUCTION ONLY.

FOR FURTHER DETAILS OF REGULAR EQUIPMENT REFER TO GROUP OR ALPHABETICAL INDEX FOR COMPLETE OPTION AVAILABILITY AND QUALIFICATIONS REFER TO DRAWING NO.

EQUIPMENT	S A N D M A N	K / W O O D	8 W M			8 W N			8 W P		8 W Q		8 W S		8 W T	
			6 0	7 0	8 0	3 5	6 9	7 0	8 0	3 5	6 9	6 9	6 9	6 9	6 9	6 9
MECHANICAL																
SUSPENSION																
FRONT STABILIZER BAR	S	S	S	S	S	S	S	S	S	S	S	S	S	S	S	S
REAR STABILIZER BAR	S	S	S	S	S	S	S	S	S	S	S	S	S	S	S	S
REAR AXLE - SEE POWER TRAIN CHART FOR AVAILABILITY																
BRAKES																
POWER ASSISTED FRONT WHEEL VENTED DISC.	S	S	S	S	S	S	S	S	S	S	S	S	S	S	S	S
REAR WHEEL ANTI-LOCK															A	A
REAR WHEEL DISC	A	A	-	A	A	A	A	A	A	A	A	A	S	S	S	S
ENGINE																
3.3 L6 HIGH COMPRESSION			S	S	S	S	S	S	S	S	S	S	S	S		
3.3 L6 LOW COMPRESSION			A	A	A	A	A	A	A	A	A	A	A	A		
4.2 V8 HIGH COMPRESSION			S	A	A	A	A	A	A	A	A	A	S	S		
5.0 V8 HIGH COMPRESSION			A	A	-	A	A	A	A	A	A	A	A	S	S	S
TRANSMISSIONS - SEE POWER TRAIN AVAILABILITY CHARTS																
3 - SPEED MANUAL 3.07:1 1ST GEAR - (P/O M15)			S	S	S	S	S	S	S	S	S	S	S	S		
4 - SPEED MANUAL 3.05:1 1ST GEAR - (P/O M20)			S	A	A	A	A	A	A	A	A	A	A	A		
4 - SPEED MANUAL 2.54:1 1ST GEAR - (P/O M21)			A	A	-	A	A	A	A	A	A	A	A	A	S	
4 - SPEED MANUAL 3.74:1 1ST GEAR - (P/O M22)			A	A	A	A	A	A	A	A	A	A	A	A		
AUTOMATIC TRANSMISSION - TRIMATIC (P/O M40)			A	A	A	A	A	A	A	A	A	A	S	S	A	
AUTOMATIC TRANSMISSION - TURBO HYDRA-MATIC 400 (ONLY WITH 5.0L ENGINE)			A	A	-	A	A	A	A	A	A	A	A	A	S	S
CABLE CLUTCH CONTROL			S	S	S	S	S	S	S	S	S	S	S	S		
EXHAUST																
SINGLE			S	S	S	S	S	S	S	S	S	S	S	S	S	
DUAL - V8 ONLY			-	A	-	-	-	A	-	-	-	A	S	S	S	

S = STANDARD A = AVAILABLE - = NOT AVAILABLE

Issued: APRIL, 1977 Revised: JULY, 1978

HOLDEN 'HIZ' FEATURES

GENERAL

STANDARD EQUIPMENT AND OPTION SUMMARY (Continued..)

EQUIPMENT	S A N D M A N	K / W O O D	8 W M			8 W N			8 W P	8 W Q	8 W S	8 W T
			6 0	7 0	8 0	3 5	6 9	7 0	8 0	3 5	6 9	6 9
<u>MECHANICAL</u> CONT'D.....									■	■		
<u>STEERING</u>												
OVERALL RATIO	A	A	-	A	A	A	A	A	S	S	S	S
■ POWER STEERING RATIO 18.1:1 TO 11.0:1 (STANDARD WITH FITMENT OF V8)	S	S	S	S	S	S	S	S	A	A	S	-
■ STEERING RATIO 25.0:1 (NOT AVAILABLE WITH V8 ENGINE)												
<u>WHEELS</u>												
6.00JJ x 14 (HEAVY DUTY RIM)	-	-	S	-	-	-	-	-	-	-	-	-
6.00JJ x 14	-	S	-	S	S	S	S	S	S	S	-	S
* 6.00JJ x 14 RALLY TYPE (P/O N66)	S	A	-	A	A	-	A	A	A	-	A	S
* 7.00JJ x 14 "HONEYCOMB" POLYCAST (P/O PE1)	-	A	-	-	-	-	A	-	-	A	A	A
6.00JJ x 14 CHROME DUNLOP WIRE WHEEL	-	-	-	-	-	-	-	-	A	A	A	A
HUB CAPS	-	S	S	S	S	-	S	S	-	-	-	-
* 6.00JJ X 14 CAST ALLOY WHEEL	S	A	-	A	A	A	A	A	A	A	S	A
FULL WHEEL COVER	-	-	-	-	S	S	S	S	S	S	-	S
RIM MOUNTED TRIM RING (STANDARD ON N66 & PE1 WHEELS)	S	A	-	A	A	A	A	A	-	A	S	A
<u>TYRES</u> (STANDARD EQUIPMENT ONLY)												
ER78S14	-	-	-	-	S	S	-	S	S	-	-	-
ER70H14	∅	-	-	-	-	-	-	-	-	S	-	-
FR78S14	∅	-	-	-	-	-	-	-	-	-	S	S
195SR14	-	S	-	S	S	-	S	S	-	-	-	-
195SR14LT	-	-	S	-	-	-	-	-	-	-	-	-
∅ SANDMAN TYRES SUBJECT TO G.V.W. RESTRICTIONS.												
* RALLY & POLYCAST WHEELS ARE SUPERSEDED BY THE ALLOY WHEEL AFTER S.O.P.												
S = STANDARD A = AVAILABLE - = NOT AVAILABLE												

Issued: APRIL, 1977 ■ Revised: JULY, 1978

HOLDEN 'HZ' FEATURES

GENERAL

STANDARD EQUIPMENT AND OPTION SUMMARY (Continued..)

EQUIPMENT	CALAIS	SANDMAN	K/WOOD	8 W M			8 W N			8 W P		8 W Q		8 W S T		
				6	7	8	3	6	7	8	3	6	6	6	6	6
				0	0	5	5	9	0	5	9	9	9	9	9	9
<u>MECHANICAL CONT'D.....</u>																
<u>JACKING SYSTEM</u>																
BUMPER JACK	S	-	S	-	-	-	-	S	-	-	S	S	S	S		
SCISSOR JACK	-	-	-	-	-	-	S	-	-	S	-	-	-	-		
BOTTLE JACK	-	S	-	S	S	S	-	S	S	-	-	-	-	-		
<u>FUEL TANK CAPACITY</u>																
16.5 IMP. GALLONS (75 LITRES)	S	-	S	-	-	-	S	S	-	-	S	S	S	S	S	
15.5 IMP. GALLONS (70 LITRES)	-	S	-	S	S	S	-	S	S	-	-	-	-	-		
<u>EXTERNAL</u>																
<u>BUMPERS - FRONT</u>																
PAINTED	-	-	-	S	-	-	-	-	-	-	-	S	-	-		
CHROME	S	S	S	-	S	S	S	S	S	S	S	S	A	S	S	
BUMPER BAR RUB STRIP	S	A	A	-	A	A	A	A	A	S	S	S	S	S	S	
BUMPER BAR OVERRIDER	S	-	-	-	-	-	-	-	-	S	S	-	S	S		
<u>BUMPERS - REAR</u>																
PAINTED	-	-	-	-	-	-	-	-	-	-	-	S	-	-		
CHROME	S	-	S	-	-	-	S	S	-	S	S	A	S	S		
CHROME BUMPERETTES	-	S	-	S	S	-	-	S	S	-	-	-	-	-		
BUMPER BAR RUB STRIP	S	-	A	-	-	-	A	A	-	S	S	S	S	S		
BUMPER BAR OVERRIDER	S	-	-	-	-	-	-	-	-	-	S	-	S	S		
S = STANDARD A = AVAILABLE - = NOT AVAILABLE																

Issued: APRIL, 1977 Revised: AUGUST, 1977

HOLDEN 'HIZ' FEATURES

GENERAL

EQUIPMENT	S A N D M A N	K / W O O D	8 W M	8 W N	8 W P	8 W Q	8 W S	8 W T
			6 0 0	7 8 0	3 6 5	7 8 0	3 6 5	6 6 9
<u>EXTERNAL CONT'D.....</u>				■				
<u>HEADLAMPS</u>								
CIRCULAR SINGLE 7" (178mm) SEALED BEAMS	-	S	-	S	S	-	-	-
CIRCULAR SINGLE 7" (178mm) QUARTZ HALOGEN SEMI-SEALED BEAMS	-	A	A	A	A	S	S	A
CIRCULAR DUAL 5-3/4 (146mm) QUARTZ HALOGEN SEMI-SEALED BEAMS	-	-	-	-	-	-	S	S
CIRCULAR SINGLE 7" (178mm) SEALED BEAMS INCORPORATING PARKING LAMPS	-	S	-	-	-	-	-	-
CIRCULAR DUAL 5 3/4 (146mm) QUARTZ HALOGEN SEMI-SEALED BEAMS WITH LONG RANGE HI-BEAM	S	-	-	-	-	-	-	S
<u>TURN SIGNAL AND PARKING LAMPS - FRONT</u>								
VERTICAL DESIGN TURN SIGNAL AND PARKING LAMPS IN FENDER LEADING EDGES	S	S	-	S	S	S	S	S
CIRCULAR DESIGN TURN SIGNALS INBOARD OF COMBINED HEAD AND PARKING LAMPS	-	-	S	-	-	-	-	-
<u>REAR VISION MIRROR</u>								
GLARE REDUCED 5-1/2" x 4" (139.7 x 101.6 mm) RECTANGULAR DESIGN DOOR MOUNTED - DRIVER'S SIDE	■	-	S	-	S	S	-	-
GLARE REDUCED 5-1/2" x 4" (139.7 x 101.6 mm) RECTANGULAR DESIGN DOOR MOUNTED - PASSENGER'S SIDE	-	-	-	S	S	-	S	-
REMOTE CONTROL - GLARE REDUCED 5-1/2" x 4" (139.7 x 101.6 mm) RECTANGULAR DESIGN. DOOR MOUNTED - DRIVER'S SIDE	■	-	A	-	A	A	S	S
GLARE REDUCED 7" x 5" (177.8 x 127.0 mm) RECTANGULAR DESIGN. DOOR MOUNTED - DRIVER'S AND PASSENGER'S SIDE	-	-	S	-	-	-	-	-
GLARE REDUCED RECTANGULAR DESIGN IN STREAMLINED HOUSING. DOOR MOUNTED DRIVER'S AND PASSENGER'S SIDE	S	-	-	-	-	-	-	S
<u>ENGINE HOOD SILENCER</u>								
(ALSO STANDARD ON 8WN MODELS WITH L6 AUTOMATIC)	-	-	-	-	-	-	S	S
<u>ROOF</u>								
EXTERIOR SOFT TRIM	-	A	-	-	-	A	-	A
<u>REAR LAMPS</u>								
SIDE MARKER	S	-	-	S	S	S	-	-
VERTICALLY MOUNTED IN REAR QUARTER, UPPER STOP/TAIL, LOWER TURN SIGNAL/BACK-UP	S	-	-	S	S	S	-	-
UNIVERSAL TYPE TURN SIGNAL/STOP, TAIL/BACK-UP	-	-	S	-	-	-	-	-
HORIZONTALLY MOUNTED IN REAR QUARTER, WRAP AROUND, UPPER STOP/TAIL, LOWER TURN SIGNAL/BACK-UP	-	S	-	-	-	-	S	S
VERTICALLY MOUNTED IN REAR QUARTER, WRAP AROUND, UPPER STOP/TAIL, LOWER TURN SIGNAL/BACK-UP	-	-	-	-	-	-	-	S
LICENCE PLATE ILLUMINATION	S	S	S	S	S	S	S	S

S = STANDARD A = AVAILABLE - = NOT AVAILABLE

Issued: APRIL, 1977 ■ Revised: JULY, 1978

HOLDEN 'HZ' FEATURES

GENERAL

STANDARD EQUIPMENT AND OPTION SUMMARY (Continued..)

EQUIPMENT	CALAIS	SANDMAN	K/W/JO	8WM			8WN			8WP			8WQ			8WT		
				60	70	80	35	67	80	35	66	99	66	99	66	99		
<u>EXTERNAL</u> CONT'D.....																		
<u>LASH-ON TONNEAU COVER</u> φ STD SANDMAN UTILITY	-	φ	-	-	-	-	-	-	S	-	-	-	-	-	-	-	-	-
<u>INTERNAL</u>																		
<u>FRONT SEATS AND CONSOLE</u>																		
BENCH WITH CENTRE FOLDING ARMREST	A	-	S	S	S	S	A	A	S	S	A	A	-	A	-	-	-	-
RECLINING BUCKET WITH PASSIVE INTEGRAL HEAD RESTRAINTS	S	S	-	A	A	A	S	S	A	A	S	S	S	S	S	S	S	S
SEAT SEPARATOR (ONLY WITH BUCKET SEATS)	-	-	-	A	A	A	S	S	A	A	-	-	-	-	-	-	-	-
CONSOLE FLOORSHIFT (ONLY WITH BUCKET SEATS)	S	S	-	A	A	A	A	A	A	S	S	S	S	S	S	S	S	S
MAP POCKETS FITTED TO FRONT SEAT BACKS	S	-	-	-	-	-	-	-	-	S	S	S	S	S	S	S	S	S
<u>REAR SEATS</u>																		
BENCH	-	S	-	-	-	-	S	S	-	-	-	-	-	-	-	-	-	-
BENCH WITH CENTRE FOLDING ARM-REST	S	-	A	-	-	-	A	A	-	-	S	S	-	S	-	-	-	-
CONTOURED BENCH	-	-	-	-	-	-	-	-	-	-	-	-	-	S	-	-	-	-
CONTOURED BENCH WITH CENTRE FOLDING ARM-REST	-	-	-	-	-	-	-	-	-	-	-	-	-	-	-	-	-	S
<u>ARM-RESTS</u>																		
FRONT DOOR	S	S	-	-	-	-	S	S	S	S	S	S	S	S	S	S	S	S
SEAT SEPARATOR	-	-	-	-	-	-	S	S	-	-	-	-	-	-	-	-	-	-
CONSOLE	S	S	-	-	-	-	-	-	-	-	S	S	S	S	S	S	S	S
REAR SEAT CENTRE	S	-	-	-	-	-	A	A	-	-	S	S	-	S	S	-	-	-
REAR DOOR	S	-	-	-	-	-	S	-	-	-	S	S	S	S	S	S	S	S
<u>ASSIST HANDLES</u> (1 FRONT, 2 REAR)	S	-	-	-	-	-	S	A	-	-	S	A	S	S	S	S	S	S
<u>FLOOR COVERING</u>																		
INTERIOR - RUBBER MAT	-	-	A	S	S	S	A	A	A	A	-	-	-	-	-	-	-	-
- CARPET (STANDARD ON 8WM MODELS WITH BUCKET SEATS)	S	-	S	-	-	-	S	S	S	S	S	S	S	S	S	S	S	S
LUGGAGE COMPARTMENT - RUBBER MAT	-	-	S	-	-	-	S	S	-	-	S	S	-	-	-	-	-	-
- CARPET	S	-	-	-	-	-	-	-	-	-	-	-	-	-	-	-	-	S
SPARE WHEEL COVER - P.V.C.	-	-	-	-	-	-	-	-	-	-	-	-	-	-	-	-	-	S
- CARPET	S	-	-	-	-	-	-	-	-	-	-	-	-	-	-	-	-	S
- CLIP ON HARDBOARD PANEL	-	-	S	-	-	-	S	-	-	-	S	-	-	-	-	-	-	-

S = STANDARD A = AVAILABLE - = NOT AVAILABLE

Issued: APRIL, 1977 Revised: OCTOBER, 1977

HOLDEN 'HIZ' FEATURES

GENERAL

STANDARD EQUIPMENT AND OPTION SUMMARY (Continued..)

EQUIPMENT	S A N D O M A N	K W O C D	8 W M			8 W N			8 W P		8 W Q		8 W S	
			6 0	7 0	8 5	3 9	6 0	7 0	8 5	3 9	6 9	6 9	6 9	6 9
<u>INTERNAL CONT'D.....</u>														
FRONT DOOR MAP POCKET	-	-	-	-	-	-	-	-	-	-	-	-	S	
<u>ASH TRAYS</u>														
INSTRUMENT PANEL ASH TRAY (ILLUMINATED) SINGLE CENTRAL DRAWER	S	S	S	S	S	S	S	S	S	S	S	S	S	
FRONT SEAT BACK	-	S	-	-	A	A	-	-	-	-	-	-	-	
REAR DOOR ARM RESTS	-	-	-	-	-	-	-	-	S	-	S	S	S	
REAR OF CONSOLE (SWIVEL TYPE)	-	-	-	-	A	A	-	S	-	S	-	-	-	
REAR OF SEAT SEPARATOR (SWIVEL TYPE)	-	-	-	-	S	S	-	-	-	-	-	-	-	
<u>REAR VISION MIRROR</u>														
PRISMATIC ANTIGLARE - SHATTER RESISTANT WITH SPRING LOADED KNOCK-OUT MOUNTING	-	-	-	-	-	-	-	-	S	S	S	S	S	
GLARE REDUCED - SHATTER RESISTANT WITH SPRING LOADED KNOCK-OUT MOUNTING	S	S	-	S	S	S	S	S	-	-	-	-	-	
<u>SEAT BELTS</u>														
FRONT - LAPSASH RETRACTING VEHICLE SENSITIVE	S	S	S	S	S	S	S	S	S	S	S	S	S	
- LAP CENTRE POSITIONS - NON RETRACTING	S	S	S	S	A	A	S	S	A	A	-	A	-	
REAR - LAPSASH RETRACTING VEHICLE SENSITIVE	-	A	-	-	-	A	-	-	S	S	S	S	S	
- LAPSASH - NON RETRACTING	-	S	-	-	S	S	-	S	-	-	S	-	-	
- LAP CENTRE POSITIONS - NON RETRACTING	-	S	-	-	S	S	-	S	S	S	-	S	-	
<u>MISCELLANEOUS</u>														
INSTRUMENT PANEL COMPARTMENT WITH LOCKING DOOR	S	S	S	S	S	S	S	S	S	S	S	S	S	
COAT HOOKS	-	-	-	-	S	S	-	-	S	S	S	S	S	
DOOR LOCKING BUTTONS - BLACK FINISH	S	S	S	S	S	S	S	S	-	-	-	-	-	
- CHROME FINISH	-	-	-	-	-	-	-	-	S	S	S	S	S	
SIDE DOOR POWER LOCKING SYSTEM	-	-	-	-	-	-	-	-	-	-	A	S	-	
SILL PLATES - CHROME PLATED STEEL	S	S	S	S	S	S	S	S	S	S	S	S	S	
WINDSHIELD - SAFETY GLASS	■	S	S	S	S	-	S	S	-	S	-	-	-	
- LAMINATED GLASS (TINTED)	■	A	A	A	A	S	S	A	A	-	A	S	S	
- LAMINATED GLASS (NON TINTED)	■	A	A	A	A	-	A	A	S	S	A	-	-	
ELECTRIC HEATED REAR WINDOW	-	A	-	-	-	S	-	-	S	S	S	S	S	
VANITY MIRROR - FITTED INSIDE INSTRUMENT PANEL COMPARTMENT	-	-	-	-	-	-	-	-	-	-	-	S	S	
VINYL AND NYLON TRIM	-	-	-	-	A	A	-	-	A	A	A	A	A	
POWER OPERATED SIDE WINDOWS	-	-	-	-	-	-	-	-	A	A	A	A	S	
MANUAL CONTROL AIR-CONDITIONING	■	A	A	A	A	A	A	A	A	A	A	S	S	
TINTED SIDE & REAR WINDOWS	■	A	A	A	A	A	A	A	S	S	S	S	S	
HANDGRIPS ABOVE PASSENGER DOORS	■	-	-	-	S	-	-	-	S	-	S	S	S	

S = STANDARD A = AVAILABLE - = NOT AVAILABLE

Issued: APRIL, 1977 ■ Revised: JULY, 1978

HOLDEN 'HIZ' FEATURES

GENERAL

STANDARD EQUIPMENT AND OPTION SUMMARY (Continued..)

EQUIPMENT	S A N D M A N	K W O O D	8 W M			8 W N			8 W P			8 W Q			8 W S		
			6	7	8	3	6	7	8	3	6	6	6	6	6	6	6
			0	0	0	5	9	0	0	5	9	5	9	9	9	9	9
<u>INTERNAL</u> CONT'D.....																	
<u>INTERIOR LIGHTING</u>																	
DOME - LIGHT SWITCH CONTROLLED	S	S	S	S	S	S	S	S	S	S	S	S	S	S	S	S	S
- FRONT DOOR SWITCH ACTIVATED	S	S	-	-	S	S	S	S	S	S	S	S	S	S	S	S	S
- REAR DOOR SWITCH ACTIVATED	-	-	-	-	-	-	-	-	S	S	S	S	S	S	S	S	S
- FRONT SEAT READING LAMPS INDIVIDUAL SWITCH CONTROLLED (INCORPORATED IN DOME LAMP)	-	-	-	-	-	-	-	-	-	-	-	-	-	-	-	-	-
FOOTWELL - LIGHT SWITCH CONTROLLED	S	-	-	-	-	-	-	-	S	S	S	S	S	S	S	S	S
- FRONT DOOR SWITCH ACTIVATED	-	-	-	-	-	-	-	-	S	S	S	S	S	S	S	S	S
- REAR DOOR SWITCH ACTIVATED	-	-	-	-	-	-	-	-	S	S	S	S	S	S	S	S	S
REAR QUARTER LAMPS - LIGHT SWITCH CONTROLLED	-	-	-	-	-	-	-	-	-	-	-	-	-	S	-	-	-
- FRONT DOOR SWITCH ACTIVATED	-	-	-	-	-	-	-	-	-	-	-	-	-	-	S	-	-
- REAR DOOR SWITCH ACTIVATED	-	-	-	-	-	-	-	-	-	-	-	-	-	-	S	-	-
- REAR QUARTER READING LAMP SWITCH CONTROLLED	-	-	-	-	-	-	-	-	-	-	-	-	-	-	-	S	-
FRONT & REAR DOOR COURTESY WARNING LAMPS. - (RED & WHITE LENSES IN LOWER PART OF DOOR)	-	-	-	-	-	-	-	-	-	-	-	-	-	-	-	S	-
- DOOR ACTIVATED (FRONT OR REAR)	-	-	-	-	-	-	-	-	-	-	-	-	-	-	-	S	-
- LIGHT SWITCH ACTIVATED	-	-	-	-	-	-	-	-	-	-	-	-	-	-	-	S	-
INSTRUMENT PANEL COMPARTMENT (GLOVE BOX)	-	-	-	-	-	-	-	-	S	S	S	S	S	S	S	S	S
LUGGAGE COMPARTMENT	-	-	-	-	-	-	-	-	-	S	S	S	S	S	S	S	S
INSTRUMENT PANEL ILLUMINATION	S	S	S	S	S	S	S	S	S	S	S	S	S	S	S	S	S
WARNING LAMPS -- (SEE INSTRUMENTS & CONTROLS) --																	
ASHTRAY AND CIGAR LIGHTER ILLUMINATION	S	S	S	S	S	S	S	S	S	S	S	S	S	S	S	S	S
<u>INSTRUMENTS & CONTROLS</u>																	
ALL INSTRUMENTS INCORPORATE INTERNATIONAL SYMBOLS	S	S	S	S	S	S	S	S	S	S	S	S	S	S	S	S	S
COMBINED INSTRUMENT CLUSTER - 220 KM/H SPEEDO, OIL, BATTERY, TEMPERATURE, FUEL GAUGES, CLOCK, TACHOMETER	S	A	A	A	A	A	A	A	A	A	A	A	A	A	S	-	-
WARNING LIGHTS - OIL	-	S	S	S	S	S	S	S	S	S	S	S	S	-	S	-	-
- TEMPERATURE	-	S	S	S	S	-	-	-	-	-	-	-	-	-	-	-	-
- GEN. PARK BRAKE, BRAKE FAILURE, HI-BEAM	S	S	S	S	S	S	S	S	S	S	S	S	S	S	S	S	S
- TURN SIGNAL	S	S	S	S	S	S	S	S	S	S	S	S	S	S	S	S	S
GAUGES - FUEL	S	S	S	S	S	S	S	S	S	S	S	S	S	S	S	S	S
- OIL	S	A	A	A	A	A	A	A	A	A	A	A	A	S	-	S	-
- TEMPERATURE	S	A	A	A	A	S	S	S	S	S	S	S	S	S	S	S	S
- BATTERY	S	A	A	A	A	A	A	A	A	A	A	A	A	A	S	-	S
- TACHOMETER	S	A	A	A	A	A	A	A	A	A	A	A	A	S	-	-	-
- SPEEDOMETER - 200 KM/H	-	S	S	S	S	S	S	S	S	S	S	S	S	A	-	-	-
- 220 KM/H	-	S	A	A	A	A	A	A	A	A	A	A	A	A	S	S	S
TRIPMETER ODOMETER	S	S	-	-	-	-	-	-	-	-	-	-	-	S	S	S	S
CLOCK - STANDARD TYPE	S	A	A	A	A	S	A	S	A	S	A	S	A	S	S	S	S
- DIGITAL TYPE	-	-	-	-	-	-	-	-	-	-	-	-	-	-	-	-	-
■ RADIO - AM	A	A	A	A	A	A	A	A	A	A	A	A	A	S	S	S	-
- AM/FM STEREO	■	A	A	A	A	A	A	A	A	A	A	A	A	A	A	A	S

S = STANDARD A = AVAILABLE - = NOT AVAILABLE

Issued: APRIL, 1977 ■ Revised: JULY, 1978

HOLDEN 'HIZ' FEATURES

GENERAL

STANDARD EQUIPMENT AND OPTION SUMMARY (Continued..)

EQUIPMENT	S A N D M A N	K I N G S W O O D	8 W M			8 W N			8 W P	8 W Q	8 W S	8 W T
			6	7	8	3	6	7	8	3	6	6
<u>INTERNAL CONT'D.....</u>			0	0	0	5	0	0	5	9	9	9
<u>INSTRUMENTS AND CONTROLS</u> Cont'd...												
CIGAR LIGHTER - IN INSTRUMENT PANEL (ILLUMINATED) - IN REAR OF CONSOLE	S	S	-	-	-	S	S	S	S	S	S	S
ANTENNA - LOCK DOWN - POWER WITH AUTOMATIC RETRACT	A	A	A	A	A	A	A	A	S	S	S	-
HOOD RELEASE	S	S	S	S	S	S	S	S	S	S	S	S
HORN - LOW NOTE - HIGH NOTE	S	S	S	S	S	S	S	S	S	S	S	S
STEERING WHEEL - OVAL 16" x 15" (406 x 381 mm) - CIRCULAR SPORTS 15½" (394 mm) - CIRCULAR 15½" (394 mm)	S	S	S	S	S	S	S	S	S	S	S	S
INTEGRATED SCREEN WIPER/WASHER SWITCH - 2 SPEED WIPER	S	S	S	S	S	S	S	S	S	S	S	S
CHOKE CONTROL	S	S	S	S	S	S	S	S	S	S	S	S
POWER ENDGATE SWITCH	-	-	-	-	-	A	-	-	S	-	-	-
ELECTRIC HEATED REAR WINDOW SWITCH	-	A	-	-	-	S	-	-	S	S	S	S
AIR-CONDITIONING CONTROLS	A	A	A	A	A	A	A	A	A	A	A	S
HEATER/DEMISTER CONTROLS	S	S	S	S	S	S	S	S	S	S	S	S
AUTOMATIC TRANSMISSION QUADRANT INDICATOR	A	A	A	A	A	A	A	A	S	S	A	S
VENTILATION - FORCED AIR	S	S	S	S	S	S	S	S	S	S	S	-
CONSOLE MOUNTED CASSETTE STEREO TAPE PLAYER WITH 4 SPEAKERS	-	-	-	-	-	-	-	-	-	-	-	S
WIPER, TIMED SINGLE SWEEP CONTROL	A	A	A	A	A	A	A	A	S	S	S	S
REMOTE CONTROL VACUUM OPERATED LUGGAGE COMPARTMENT LID (PART OF TAXI PACKAGE ON 8WN AND 8WN)	-	-	-	-	-	-	-	-	-	-	-	S
STEERING COLUMN MOUNTED COMBINED WASH, WIPE, FLASH & DIP CONTROL INCORPORATING 2 SPEED WIPER & SINGLE SWEEP POSITION, TURN SIGNALS, DIP AND HEADLAMP FLASHERS	S	S	S	S	S	S	S	S	S	S	S	S
<u>VEHICLE PACKAGES</u>												
SANDMAN	-	-	-	A	A	-	-	-	-	-	-	-
PASSENGER DERIVATIVE 10 cwt. UTE & PANEL VAN (REGISTRATION REBATE VICTORIA)	-	-	-	A	A	-	-	A	A	-	-	-
TAXI	-	-	-	-	-	-	-	A	-	-	-	-
AMBULANCE	-	-	-	A	A	-	-	-	-	-	-	-
DERATED KINGSWOOD 'SL' - KINGSWOOD FLEET OWNER USEAGE	-	-	-	-	-	-	-	A	-	-	-	-
STATESMAN CALAIS	-	-	-	-	-	-	-	-	-	-	-	A

S = STANDARD A = AVAILABLE - = NOT AVAILABLE

Issued: APRIL, 1977 Revised: JULY, 1978

HOLDEN 'HZ' FEATURES

GENERAL

SAFETY FEATURES

THE COMPREHENSIVE LIST OF SAFETY FEATURES OF THE PREVIOUS MODELS IS CARRIED OVER INTO HZ MODELS AS LISTED BELOW :-

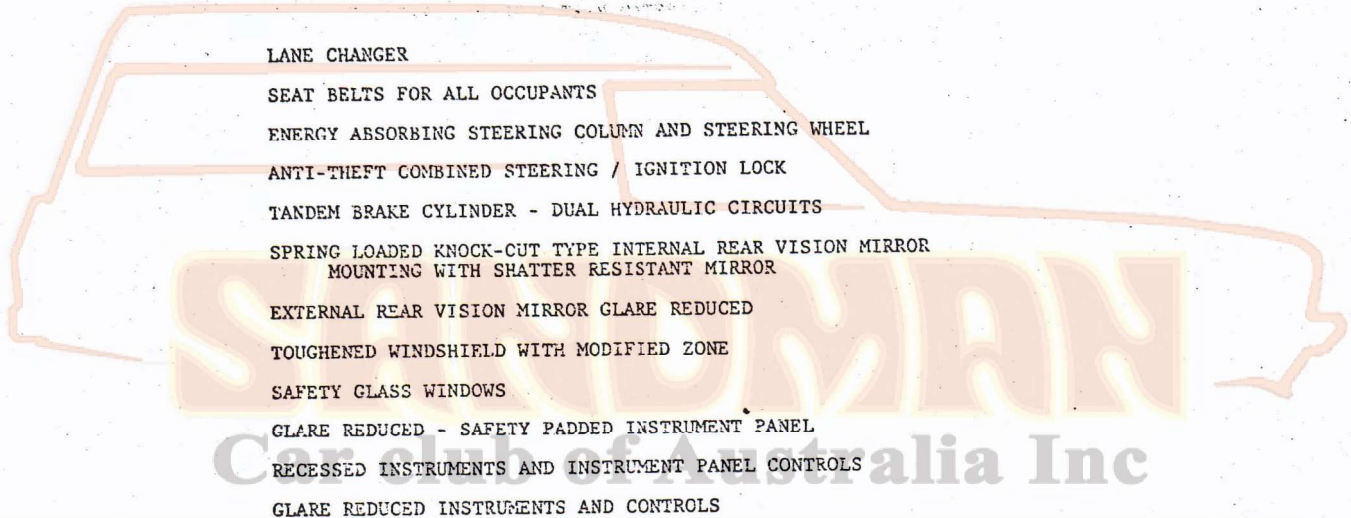

LANE CHANGER
SEAT BELTS FOR ALL OCCUPANTS
ENERGY ABSORBING STEERING COLUMN AND STEERING WHEEL
ANTI-THEFT COMBINED STEERING / IGNITION LOCK
TANDEM BRAKE CYLINDER - DUAL HYDRAULIC CIRCUITS
SPRING LOADED KNOCK-CUT TYPE INTERNAL REAR VISION MIRROR
MOUNTING WITH SHATTER RESISTANT MIRROR
EXTERNAL REAR VISION MIRROR GLARE REDUCED
TOUGHENED WINDSHIELD WITH MODIFIED ZONE
SAFETY GLASS WINDOWS
GLARE REDUCED - SAFETY PADDED INSTRUMENT PANEL
RECESSED INSTRUMENTS AND INSTRUMENT PANEL CONTROLS
GLARE REDUCED INSTRUMENTS AND CONTROLS
LOW PROFILE WINDOW REGULATOR HANDLES
SUN VISORS - ENERGY ABSORBING
FLUSH FITTING LIFT-UP EXTERIOR DOOR HANDLES
SAFETY DOOR LOCKS - HANDLES FREE-WHEEL
4-JET ELECTRIC WINDSHIELD WASHER
2 SPEED WINDSHIELD WIPERS WITH GLARE REDUCED ARMS AND
BLADES (MATT BLACK)
CIGAR LIGHTER OPERATES ON IGNITION OR ACCESSORY POSITIONS ONLY
BACK-UP LAMPS
FLOW THROUGH VENTILATION
FUSIBLE LINK IN WIRING HARNESS
FAN ASSISTED HEATER DEMISTER
BRAKE FAILURE LAMP
SAFETY FLANGES ON BOTH RIMS OF ROAD WHEELS
FRONT SEAT HEAD RESTRAINTS
UNDERSLUNG FUEL TANK & EXTERNAL FUEL LINES
SKID HEADER PANEL
FLOOR MOUNTED HANDBRAKE
PARKING BRAKE WARNING LAMP

Issued: APRIL, 1977 Revised:

HOLDEN 'HIZ' FEATURES

STYLING - EXTERIOR

INDEX TO SECTION B

INTRODUCTION	B-1
NEW MODEL TO THE RANGE	B-2
PRODUCTION MODEL DESCRIPTION	B-3 TO B-5
KINGSWOOD SL SEDAN	B-6, B-7
KINGSWOOD SL STATION WAGON	B-8
KINGSWOOD (A9K) SEDAN	B-9, B-10
KINGSWOOD (A9K) STATION WAGON	B-11
PREMIER SEDAN	B-12, B-13
PREMIER STATION SEDAN	B-14
'GTS' SEDAN	B-15, B-16
STATESMAN DEVILLE	B-17, B-18
■ STATESMAN CALAIS	B-19, B-20
STATESMAN CAPRICE	B-21, B-22
SANDMAN	B-23
KINGSWOOD UTILITY	B-24, B-25
KINGSWOOD PANEL VAN	B-26
HOLDEN UTILITY	B-27, B-28
HOLDEN PANEL VAN	B-29
HOLDEN CHASSIS & CAB	B-30

■ REFER PAGE A-1, B-9.

Issued: JUNE, 1977 ■ Revised: OCTOBER, 1977

ITEM X

HOLDEN 'HZ' FEATURES

STYLING - EXTERIOR

THE 'HZ' EXTERIOR STYLING CONSISTS OF AN ORNAMENTATION CHANGE TO THE 'HX' BODY.

THE BODY STYLE RANGE CONTINUES UNCHANGED, BUT THE MODEL LINE-UP IS REVISED BY DELETION OF BELMONT MODELS. KINGSWOOD 'SL' PASSENGER MODELS HAVE BEEN ADDED SUPERSEDING THE KINGSWOOD WHICH HOWEVER REMAINS AVAILABLE AS A PRODUCTION OPTION MODEL. THE STATESMAN CALAIS WILL ALSO BE INTRODUCED AS A PRODUCTION OPTION MODEL AFTER START OF PRODUCTION.

CHANGES TO EXTERNAL APPEARANCE IS MADE TO ALL MODELS.

THE IDENTIFICATION PLATES ARE RELOCATED IN A MORE PROMINENT POSITION TO IMPROVE MODEL RECOGNITION. STATESMAN DEVILLE HAS NEW SCRIPT TYPE DEVILLE LETTERING TO MATCH THE OTHER STATESMAN MODELS.

NEW GRILLES ARE FEATURED ON ALL MODELS.

THE STATESMAN DECK LID STYLE IS ADDED TO ALL SHORT WHEELBASE SEDANS TO IMPROVE SERIES IDENTIFICATION. THE GTS RETAINS THE CARRYOVER DECK LID STYLE BUT THE FRONT AIR DAM AND DECK LID SPOILER ARE NOW STANDARD EQUIPMENT.

NEW BRIGHT WIDE VINYL FILLED MOULDING IS FITTED TO ALL MODELS FROM KINGSWOOD 'SL' UP EXCEPT GTS.

THE STAINLESS STEEL UPPER BODY MOULDINGS ON STATESMAN MODELS ARE NOW BRIGHT NICKEL CHROME PLATE.

BUMPER BARS FOR PREMIER, GTS, DEVILLE AND CAPRICE RETAIN THE RUBBER INSERT WITH PREMIER AND DEVILLE HAVING VERTICAL RUBBER FACED BUMPER GUARDS ADDED. KINGSWOOD 'SL' ALSO HAS RUBBER INSERTS.

NEW FULL WHEEL COVERS ARE USED ON KINGSWOOD 'SL', PREMIER AND STATESMAN MODELS WITH CARRYOVER 'HX' HUB CAPS ON OTHER MODELS. GTS SPORTS WHEEL PAINT TREATMENT IS NOW BODY COLOUR BACKGROUND WITH BLACK HIGHLIGHTS INSTEAD OF BLACK WITH SILVER.

QUARTZ HALOGEN HEADLAMPS ARE STANDARD EQUIPMENT ON KINGSWOOD 'SL' (2), PREMIER, STATESMAN CALAIS AND CAPRICE (4).

QUARTZ HALOGEN HEADLAMPS (4) WITH 'PENCIL BEAM' HI BEAM INBOARD LAMPS ARE STANDARD ON GTS AND SANDMAN.

THE FRONT TURN INDICATOR PARK LAMP LENSES HAVE A NEW APPEARANCE. THE TWO HORIZONTAL BARS FITTED TO 'HJ' AND 'HX' ARE NO LONGER USED.

FULL DETAILS OF EXTERIOR FEATURES CAN BE FOUND ON PAGES B-6 TO B-30.

PRODUCTION OPTION MODELS

PRODUCTION OPTION MODELS ARE CLASSIFIED AS A VEHICLE THAT WILL BE IDENTIFIED BY THE PUBLIC AS A SEPARATE MODEL. ADVERTISING LITERATURE, MOTORING CRITICS, REGISTRATION AUTHORITIES AND THE GENERAL PUBLIC HAVE IN THE PAST RECOGNISED THE 'SANDMAN' AS A MODEL AND FOR 'HZ' TWO ADDITIONAL P/O MODELS, KINGSWOOD AND STATESMAN CALAIS, WILL BE ACCEPTED IN A SIMILAR MANNER.

ALL P/O MODELS ARE BASED ON A REGULAR VEHICLE IN THE MODEL LINE-UP. THE MOST OBVIOUS VARIATION IS THE EXTERIOR STYLING AND THIS IS WHY THE VEHICLE DESCRIPTION IS CONTAINED IN THIS SECTION. OTHER CHANGES EXIST TO BOTH INTERIOR AND MECHANICAL FEATURES AND THESE ARE ALSO OUTLINED. DETAILS ON PAGES B-3, B-4 AND B-5.

Issued: JUNE, 1977 Revised:

HOLDEN '11Z' FEATURES

STYLING - EXTERIOR

NEW MODEL

'KINGSWOOD SL'

THE KINGSWOOD SL IS INTRODUCED TO PROVIDE A VEHICLE WITH THE HIGHER EQUIPMENT LEVELS DEMANDED BY THE CONSUMER MARKET.

APPEARANCE FEATURE ITEMS ARE :-

RUBBER FACED BUMPERS

FULL WHEEL COVERS

QUARTZ HALOGEN HEADLAMPS

BUCKET SEATS WITH SEAT SEPARATOR

HEATED REAR WINDOW

PUSH BUTTON RADIO

FULL DETAILS OF EXTERIOR STYLING CAN BE FOUND ON PAGES B-6 and B-7.

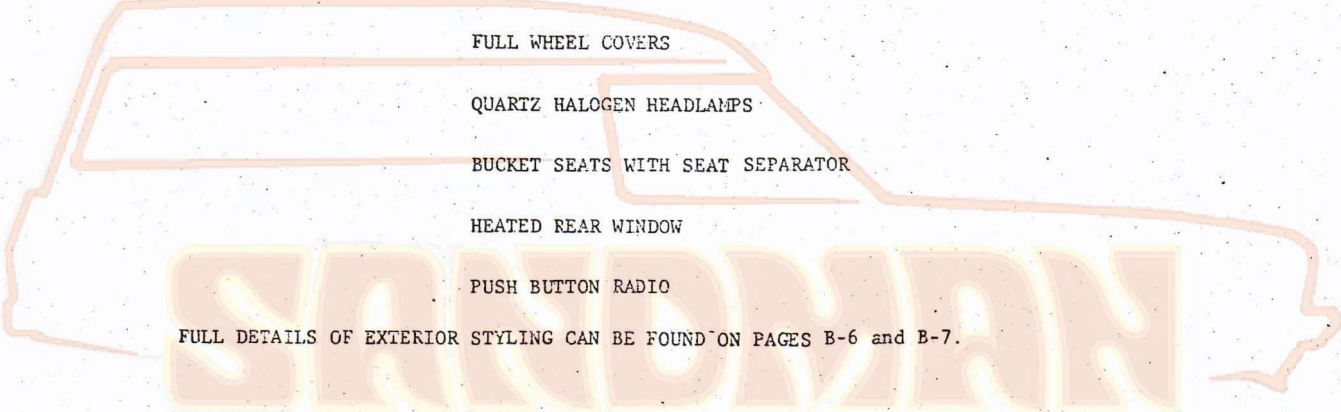

SANDMAN

Car club of Australia Inc

Issued: JUNE, 1977

Revised:

HOLDEN 'HZ' FEATURES

STYLING - EXTERIOR

KINGSWOOD

PRODUCTION OPTION A9K *

WITH THE BASE VEHICLE IN THE 'HZ' MODEL LINE-UP BEING THE 'KINGSWOOD SL' A VEHICLE OF EQUIVALENT SPECIFICATION TO THE PREVIOUS BELMONT AND KINGSWOOD IS NOT AVAILABLE.

TO PROVIDE A VEHICLE WITH A LOWER EQUIPMENT LEVEL THAN THE 'KINGSWOOD SL' AN ADDITIONAL OPTIONAL MODEL DESIGNATED 'KINGSWOOD' IS RELEASED IN BOTH SEDAN AND STATION WAGON FORM, THESE ARE PRIMARILY INTENDED AS A LOWER COST VEHICLE TO MEET THE REQUIREMENTS OF GOVERNMENT DEPARTMENT AND FLEET OWNERS.

THE VEHICLE IS BASED ON AND IS SIMILAR TO THE 'KINGSWOOD SL' WITH THE FOLLOWING VARIATIONS :-

EXTERIOR

'KINGSWOOD' BADGES REPLACE 'KINGSWOOD SL'.
HUB CAPS REPLACE FULL WHEEL COVERS.
THE BODY WIDE MOULDING IS DELETED.
RUBBER FACED BUMPERS DELETED.
QUARTZ HALOGEN HEADLAMPS DELETED AND
TUNGSTEN FILAMENT SEALED BEAMS INSERTED.
■ REMOTE CONTROL MIRROR DELETED.
■ LAMINATED SCREEN DELETED.

INTERIOR

BENCH FRONT SEAT WITH FOLDING ARMREST ONLY.
HEATED REAR WINDOW DELETED.
RADIO DELETED.
■ CLOCK DELETED.

MECHANICAL

195SR14 4 PLY TEXTILE RADIAL TYRES

- * TO AVOID CONFUSION BETWEEN THE SIMILAR MODEL NAMES 'KINGSWOOD SL' AND 'KINGSWOOD' THE
■ PRODUCTION OPTION NUMBER A9K IS ATTACHED THROUGHOUT THE FEATURES BOOK I.E. 'KINGSWOOD A9K'.
THE 'KINGSWOOD' IS ALSO AVAILABLE AS P/O A9Q OUTBACK PACKAGE OR P/O B03 TAXI PACKAGE.

Issued: JUNE, 1977 ■ Revised: JULY, 1978

HOLDEN 'HZ' FEATURES

STYLING - EXTERIOR

STATESMAN CALAIS

PRODUCTION OPTION A9P

TO BE RELEASED APPROXIMATELY SIX MONTHS AFTER HZ START OF PRODUCTION.

THE CALAIS IS AN UPGRADED VERSION OF THE DEVILLE TO BROADEN THE MARKET COVERAGE OF THE STATESMAN RANGE BY RELEASING A VEHICLE TO FILL THE GAP BETWEEN DEVILLE AND CAPRICE AND TO MATCH EQUIPMENT LEVELS IN OPPOSITION VEHICLES.

STATESMAN CALAIS VARIATIONS TO DEVILLE ARE :-

EXTERIOR

STATESMAN CALAIS

CALAIS EMBLEM ON SAIL PLANE

COLLAPSIBLE WREATH AND SHIELD HOOD ORNAMENT

REAR COMPARTMENT LID MOULDING

WHEEL COVER SIMILAR TO DEVILLE BUT WITH UNIQUE CENTRE

BRIGHT DOOR SCALP MOULDINGS IDENTICAL TO CAPRICE

MODEL CANCELLED

INTERIOR

AIRCONDITIONING STANDARD

SEATS TRIMMED IN VELOUR

POWER OPERATED WINDOWS

CALAIS BADGE ON INSTRUMENT PANEL PAD

CARPETED SPARE WHEEL COVER

MECHANICAL

SAME AS ALL STATESMAN MODELS

Issued: JUNE, 1977

Revised: OCTOBER, 1977

HOLDEN 'HZ' FEATURES

STYLING - EXTERIOR

SANDMAN

THE SANDMAN IS AVAILABLE AS A PANEL VAN OR UTILITY AND WAS INTRODUCED ON 'HJ' AS A VEHICLE TO SUIT THE DEMANDS OF THE RECREATIONAL VEHICLE MARKET. SANDMAN APPEARANCE AND EQUIPMENT LEVELS ARE DESIGNED TO PROVIDE A COMMERCIAL DERIVATIVE VEHICLE WITH THE FEATURES OF THE GTS.

FOR COMPANY CONTROL PURPOSES THE SANDMAN HAS TWO PRODUCTION OPTION NUMBERS XX7 AND XU3, HOWEVER, WITH THE EXCEPTION OF TYRE SIZE, XX7 AND XU3 VEHICLES ARE IDENTICAL.

THE TYRE SIZE CONTROLS THE PAYLOAD (CARRYING CAPACITY) OF THE VEHICLE. AS THE SANDMAN IS DESIGNED AS A RECREATIONAL VEHICLE MANY BUYERS DO NOT NEED TO CARRY MAXIMUM GVW AND AS A RESULT CAN BENEFIT IN SOME STATES, FROM A REDUCTION IN REGISTRATION COSTS BY PAYING ONLY PRIVATE REGISTRATION FOR A VEHICLE WITH A PAYLOAD OF UNDER 500 kg. (10 cwt). (THIS DERATED REGISTRATION IS ALSO AVAILABLE ON CONVENTIONAL PANEL VAN AND UTILITY MODELS).

THE TYRES FOR SANDMAN ARE - XU3, MAXIMUM PAYLOAD RATING, FR78S14 4 P/R STEEL BELTED RADIAL.
- XX7, DERATED 500 kg. (10 cwt) PAYLOAD RATING, ER70H14 6 P/R STEEL BELTED RADIAL

ALL OTHER ITEMS ARE COMMON AND ARE :-

VEHICLES ARE BASED ON THE HOLDEN PANEL VAN AND UTILITY MODELS AS THESE MODELS DO NOT HAVE MOULDINGS AND FITTINGS REQUIRING ADDITIONAL REWORK. VARIATIONS ARE LISTED AGAINST THE BASE MODEL DESCRIPTION.

EXTERIOR

GTS FRONT END PANEL INCLUDING -
4 HEADLAMPS (SAME AS GTS)
GTS GRILLE
FRONT AIR DAM IN BODY COLOUR
BLACK WINDSCREEN MOULDINGS
BLACK PAINTOUT ON DOOR FRAME AND OPENING
BLACK PAINTOUT AROUND TAILGATE WINDOW
BRIGHT 'MYLAR' INSERT IN TAILGATE WINDOW RUBBER
BLACK DOOR HANDLES
BODY COLOURED STREAM LINED EXTERIOR LEFT AND RIGHT MIRRORS.
BRIGHT TAIL LAMP SURROUNDS

INTERIOR

FULL INSTRUMENT CLUSTER ON BRUSHED BLACK CHROME PANEL.
GTS STEERING WHEEL
CIGAR LIGHTER
KINGSWOOD DOOR TRIM AND ARM RESTS
DOOR OPERATED COURTESY LIGHT
CHROME DOOR SILL PLATES
FULL LENGTH HEADLINING
GTS BUCKET SEATS
FLOORSHIFT CONSOLE
FORCED AIR VENTILATION
CARPET PASSENGER AREA

MECHANICAL

■ 4,2 V8 ENGINE
M20 4 SPEED TRANSMISSION
3.55:1 REAR AXLE RATIO
GTS WHEELS AND TRIMS WITH SILVER ON BLACK PAINTOUTS.

Issued: JUNE, 1977 ■ Revised: AUGUST, 1977

HOLDEN 'HZ' FEATURES

STYLING - EXTERIOR

KINGSWOOD SL SEDAN

RADIATOR GRILLE

ONE PIECE PLASTIC MOULDING WITH A CHROME SURROUND ENCLOSING 17 VERTICAL AND 5 HORIZONTAL BARS FORMING A MESH TYPE GRILLE OF HORIZONTALLY ALIGNED RECTANGULAR SECTIONS.

UPPER BODY DECORATION

BRIGHT FINISH REVEAL MOULDINGS ARE FEATURED AROUND THE WINDSHIELD AND REAR WINDOW TOGETHER WITH BRIGHT DRIP GUTTER MOULDINGS.

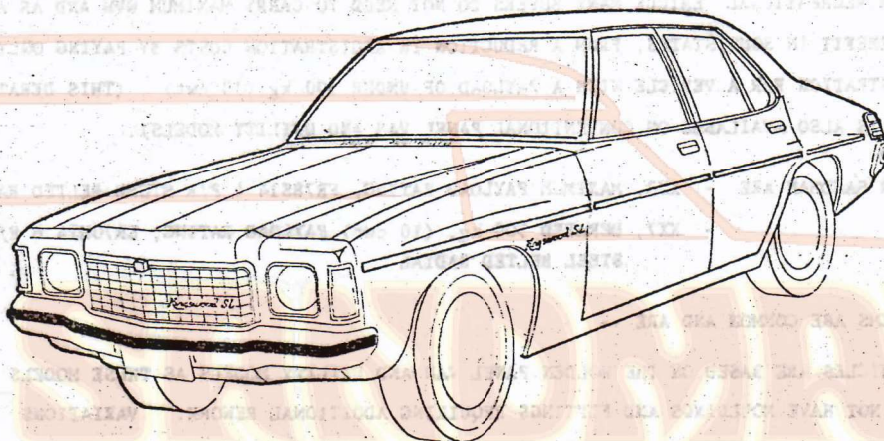

Car club of Australia Inc

FRONT TURN SIGNAL AND PARKING LAMPS

THESE ARE OF RECTANGULAR WRAP-AROUND DESIGN VERTICALLY MOUNTED IN UPPER LEADING EDGES OF FRONT FENDERS. AN OUTER CLEAR LENS ENCLOSES AN INNER AMBER TURN SIGNAL LAMP IN THE LOWER SECTION. A BRIGHT RIM SURROUNDS THE LAMP.

HEADLAMPS & BEZELS

HEADLAMPS ARE SINGLE 7 INCH (178 mm) QUARTZ HALOGEN UNITS RECESSED IN GREY PAINTED BEZELS HAVING BRIGHT RIMS.

FRONT NAMEPLATE

A KINGSWOOD SL NAMEPLATE IS LOCATED ON REAR OF FRONT FENDERS BELOW THE BODY WIDE LINE AND IN THE LEFT HAND LOWER SECTION OF THE RADIATOR GRILLE.

FRONT BUMPER BAR

BUMPER BAR IS DEEP SECTION WITH HORIZONTAL RUBBER STRIP.

EMBLEM

A SQUARE CHROME EMBLEM WITH A BLACK HOLDEN EMBLEM ON A RED BACKGROUND IS CENTRALLY MOUNTED ON THE TOP CHROME GRILLE SURROUND.

Issued: JUNE, 1977

Revised:

HOLDEN 'H/Z' FEATURES

STYLING - EXTERIOR

KINGSWOOD SL SEDAN

REAR NAMEPLATE

A KINGSWOOD SL NAMEPLATE IS LOCATED IN THE CENTRE OF THE REAR COMPARTMENT LID.

REAR BUMPER BAR

REAR BUMPER BAR IS DEEP SECTION WITH HORIZONTAL RUBBER STRIPS EITHER SIDE OF LICENCE PLATE DEPRESSION.

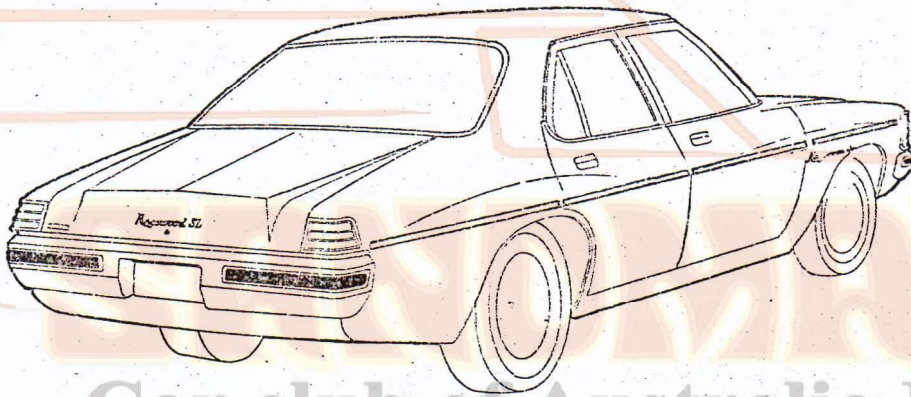

Car club of Australia Inc

TAIL LAMPS

TAIL LAMPS ARE HORIZONTALLY MOUNTED ON REAR QUARTER PANELS. THEY ARE RECTANGULAR WRAP-AROUND ONE PIECE ASSEMBLIES, COMPRISING AN UPPER STOP/ TAIL LAMP AND A LOWER TURN SIGNAL/ BACK-UP LAMP. A BRIGHT RIM WITH TWO BRIGHT HORIZONTAL RIBS IS FEATURED.

'RTS' RADIAL TUNED SUSPENSION BADGE

A RECTANGULAR BADGE TO HIGHLIGHT THE IMPROVED SUSPENSION SYSTEM IS FITTED TO THE LOWER LEFT HAND SIDE OF THE REAR COMPARTMENT LID.

BADGES

AN ENGINE IDENTIFICATION BADGE IS FITTED TO THE LOWER RIGHT HAND SIDE OF THE REAR COMPARTMENT LID WHEN A V8 IS FITTED.

BODY MOULDINGS

A WIDE STAINLESS STEEL MOULDING WITH BLACK VINYL INSERT RETAINED BY PLASTIC CLIPS EXTENDS FULL LENGTH ON BODY WIDE LINE.

Issued: JUNE, 1977 Revised:

HOLDEN 'UZ' FEATURES

STYLING - EXTERIOR

KINGSWOOD SL STATION WAGON

THE KINGSWOOD SL STATION WAGON HAS THE SAME FRONTAL APPEARANCE AS THE SEDAN MODEL. THE DRIP GUTTERS HAVE BRIGHT MOULDINGS AND THE REAR QUARTER WINDOW MOULDINGS ARE BODY COLOUR.

END GATE DECORATION

A BRIGHT REVEAL MOULDING IS FITTED AROUND ENDGATE GLASS OPENING.

BODY MOULDINGS

A WIDE STAINLESS STEEL MOULDING WITH A BLACK VINYL INSERT RETAINED BY PLASTIC CLIPS EXTENDS FULL LENGTH ON BODY WIDE LINE.

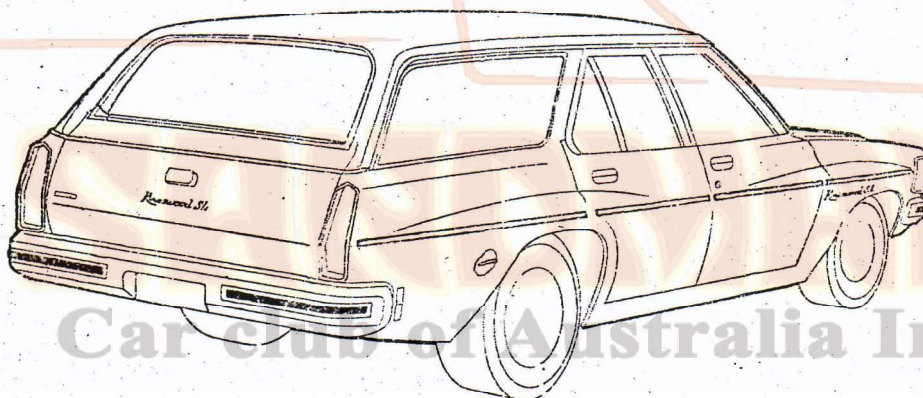

REAR BUMPER AND LIGHTS

THE REAR BUMPER BAR IS DEEP SECTION WITH HORIZONTAL RUBBER STRIPS EITHER SIDE OF LICENCE PLATE DEPRESSION. TAIL LAMPS ARE MOUNTED VERTICALLY IN THE REAR QUARTER PANELS ABOVE THE BUMPER BAR. THE UPPER SECTIONS OF THE LAMPS ARE STOP/TAIL WITH THE BOTTOM SECTIONS BEING TURN SIGNAL/BACK-UP. THE TAIL LAMPS ARE SURROUNDED BY BRIGHT DIE CAST REVEAL MOULDINGS. SIDE MARKER LAMPS ARE MOUNTED IN REAR QUARTER PANELS WHILST THE LICENCE PLATE IS ALSO FITTED IN THE CENTRAL BUMPER DEPRESSION.

REAR NAMEPLATE

A KINGSWOOD SL NAMEPLATE IS LOCATED IN THE CENTRE OF THE END GATE

BADGES

AN ENGINE IDENTIFICATION BADGE IS FITTED AT THE RIGHT HAND SIDE OF THE ENDGATE WHEN A V8 ENGINE IS FITTED.

'RTS' RADIAL TUNED SUSPENSION BADGE

A RECTANGULAR BADGE TO HIGHLIGHT THE IMPROVED SUSPENSION SYSTEM IS FITTED TO THE LEFT HAND SIDE OF THE ENDGATE ABOVE THE WIDE LINE.

Issued: JUNE, 1977

Revised:

HOLDEN 'HZ' FEATURES

STYLING - EXTERIOR

KINGSWOOD SEDAN

PRODUCTION OPTION A9K

RADIATOR GRILLE

ONE PIECE PLASTIC MOULDING WITH A CHROME SURROUND ENCLOSING 17 VERTICAL AND 5 HORIZONTAL BARS FORMING A MESH TYPE GRILLE OF HORIZONTALLY ALIGNED RECTANGULAR SECTIONS.

UPPER BODY DECORATION

BRIGHT FINISH REVEAL MOULDINGS ARE FEATURED AROUND THE WINDSHIELD AND REAR WINDOW TOGETHER WITH BRIGHT DRIP GUTTER MOULDINGS.

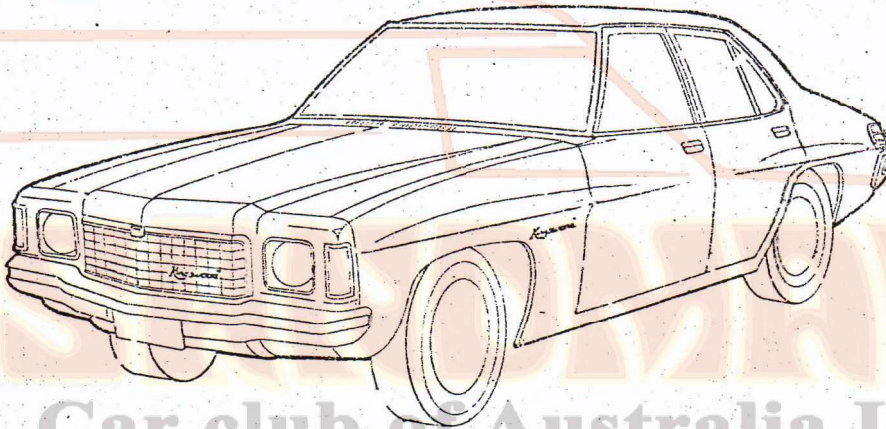

Car club of Australia Inc

FRONT TURN SIGNAL AND PARKING LAMPS

THESE ARE OF RECTANGULAR WRAP-AROUND DESIGN VERTICALLY MOUNTED IN UPPER LEADING EDGES OF FRONT FENDERS. AN OUTER CLEAR LENS ENCLOSES AN INNER AMBER TURN SIGNAL LAMP IN THE LOWER SECTION. A BRIGHT RIM SURROUNDS THE LAMP.

HEADLAMPS & BEZELS

HEADLAMPS ARE SINGLE 7 INCH (178mm) TUNGSTEN FILAMENT SEALED BEAM UNITS RECESSED IN GREY PAINTED BEZELS HAVING BRIGHT RIMS.

FRONT NAMEPLATE

A KINGSWOOD NAMEPLATE IS LOCATED ON REAR OF FRONT FENDERS BELOW THE BODY WIDE LINE AND IN THE LEFT HAND LOWER SECTION OF THE RADIATOR GRILLE.

FRONT BUMPER BAR

BUMPER BAR IS DEEP SECTION WITH HORIZONTAL RECESS.

EMBLEM

A SQUARE CHROME EMBLEM WITH A BLACK HOLDEN EMBLEM ON A RED BACKGROUND IS CENTRALLY MOUNTED ON THE TOP CHROME GRILLE SURROUND.

Issued: JUNE, 1977.

Revised:

HOLDEN 'H2' FEATURES

STYLING - EXTERIOR

KINGSWOOD SEDAN

PRODUCTION OPTION A9K

REAR NAMEPLATE

A KINGSWOOD NAMEPLATE IS LOCATED IN THE CENTRE OF THE REAR COMPARTMENT LID.

REAR BUMPER BAR

REAR BUMPER BAR IS DEEP SECTION WITH HORIZONTAL RECESS EITHER SIDE OF LICENCE PLATE DEPRESSION.

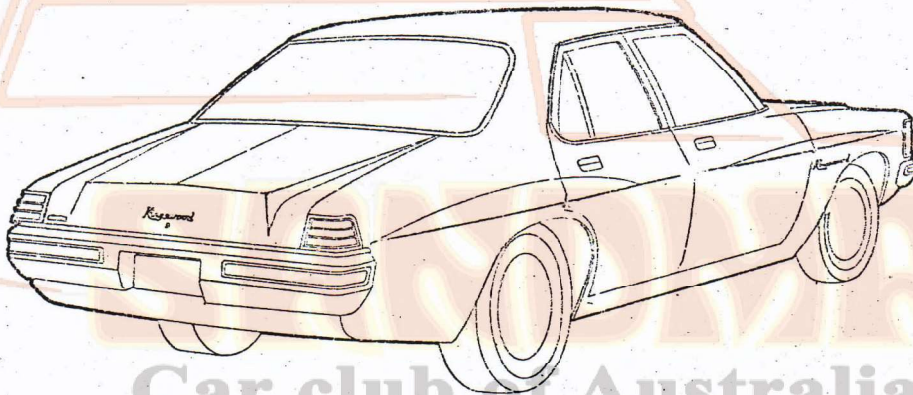

Car club of Australia Inc

TAIL LAMPS

TAIL LAMPS ARE HORIZONTALLY MOUNTED ON REAR QUARTER PANELS. THEY ARE RECTANGULAR WRAP-AROUND ONE PIECE ASSEMBLIES COMPRISING AN UPPER STOP / TAIL LAMP AND A LOWER TURN SIGNAL / BACK-UP LAMP. A BRIGHT RIM WITH TWO BRIGHT HORIZONTAL RIBS IS FEATURED.

BADGES

AN ENGINE IDENTIFICATION BADGE IS FITTED TO THE LOWER RIGHT HAND SIDE OF THE REAR COMPARTMENT LID WHEN A V6 IS FITTED.

'RTS' RADIAL TUNED SUSPENSION BADGE

A RECTANGULAR BADGE TO HIGHLIGHT THE IMPROVED SUSPENSION SYSTEM IS FITTED TO THE LOWER LEFT HAND SIDE OF THE REAR COMPARTMENT LID.

Issued: JUNE, 1977 Revised:

HOLDEN 'HZ' FEATURES

STYLING - EXTERIOR

KINGSWOOD STATION WAGON

PRODUCTION OPTION A9K

THE KINGSWOOD STATION WAGON HAS THE SAME FRONTAL APPEARANCE AS THE SEDAN MODEL. THE DRIP CUTTERS HAVE BRIGHT MOULDINGS AND THE REAR QUARTER WINDOW MOULDINGS ARE BODY COLOUR.

ENDGATE DECORATION

A BRIGHT REVEAL MOULDING IS FITTED AROUND ENDGATE GLASS OPENING.

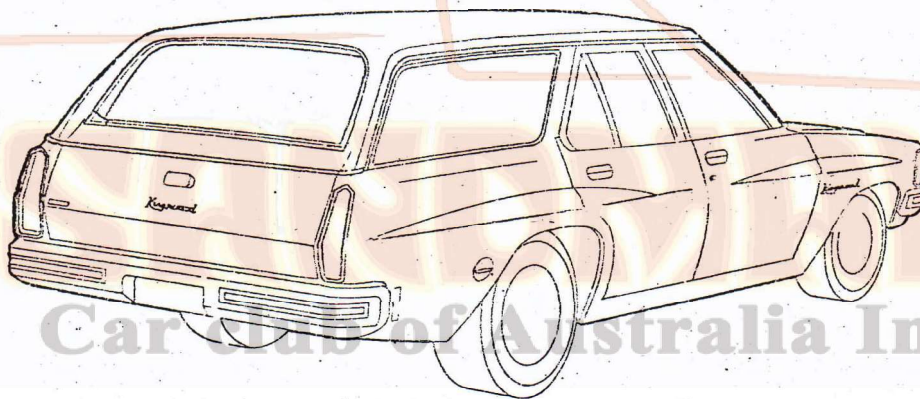

REAR BUMPER AND LIGHTS

THE REAR BUMPER BAR IS DEEP SECTION WITH HORIZONTAL RECESS EITHER SIDE OF LICENCE PLATE DEPRESSION. TAIL LAMPS ARE MOUNTED VERTICALLY IN THE REAR QUARTER PANELS ABOVE THE BUMPER BAR. THE UPPER SECTIONS OF THE LAMPS ARE STOP / TAIL WITH THE BOTTOM SECTIONS BEING TURN SIGNAL / BACK-UP. THE TAIL LAMPS ARE SURROUNDED BY BRIGHT DIE CAST REVEAL MOULDINGS. SIDE MARKER LAMPS ARE MOUNTED IN REAR QUARTER PANELS WHILST THE LICENCE PLATE IS ALSO FITTED IN THE CENTRAL BUMPER DEPRESSION.

REAR NAMEPLATE

A KINGSWOOD NAMEPLATE IS LOCATED IN THE CENTRE OF THE ENDGATE WHEN A V8 ENGINE IS FITTED.

BADGES

AN ENGINE IDENTIFICATION BADGE IS FITTED AT THE RIGHT HAND SIDE OF THE ENDGATE

'RTS' RADIAL TUNED SUSPENSION BADGE

A RECTANGULAR BADGE TO HIGHLIGHT THE IMPROVED SUSPENSION SYSTEM IS FITTED TO THE LEFT HAND SIDE OF THE ENDGATE ABOVE THE WIDE LINE.

Issued: JUNE, 1977 Revised:

HOLDEN 'HZ' FEATURES

STYLING - EXTERIOR

PREMIER SEDAN

RADIATOR GRILLE

ONE PIECE PLASTIC MOULDING WITH A CHROME SURROUND ENCLOSING 33 VERTICAL AND 5 HORIZONTAL BARS FORMING A MESH TYPE GRILLE OF SQUARE BOXES.

UPPER BODY DECORATION

BRIGHT FINISH REVEAL MOULDINGS ARE FEATURED AROUND THE WINDSHIELD AND REAR WINDOW TOGETHER WITH BRIGHT DOOR BELT LINE AND DRIP GUTTER MOULDINGS.

HEADLAMPS & BEZELS

LAMPS ARE DUAL 5 $\frac{3}{4}$ INCH (146 mm.) QUARTZ HALOGEN UNITS SET IN CHROME BEZELS

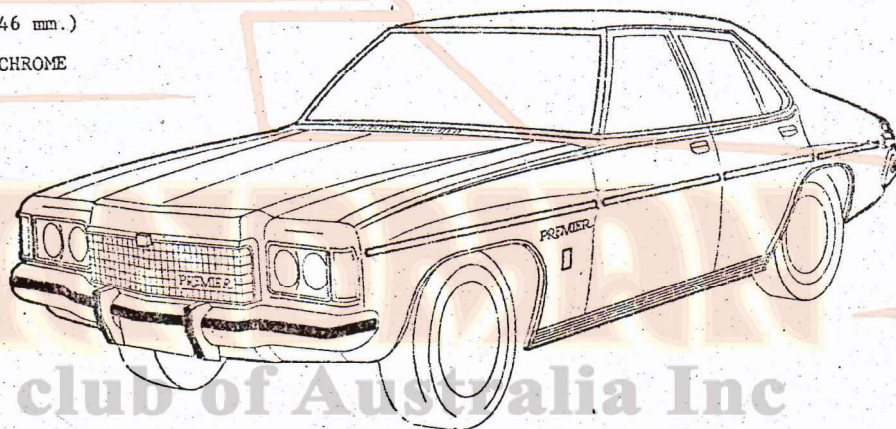

FRONT TURN SIGNAL AND PARKING LAMPS

THESE ARE OF RECTANGULAR WRAP-AROUND DESIGN VERTICALLY MOUNTED IN UPPER LEADING EDGES OF FRONT FENDERS. AN OUTER CLEAR LENS ENCLOSES AN INNER AMBER TURN SIGNAL LAMP IN THE LOWER SECTION. A BRIGHT RIM SURROUNDS THE LAMP.

FRONT BUMPER BAR

FRONT BUMPER BAR IS DEEP SECTION WITH A HORIZONTAL RUBBER STRIP. VERTICAL CHROMED BUMPER GUARDS WITH RUBBER STRIPS ARE LOCATED ON BUMPER BAR EITHER SIDE OF THE LICENCE PLATE.

FRONT NAMEPLATE

A PREMIER NAMEPLATE IS LOCATED ON REAR OF FRONT FENDERS BELOW THE BODY WIDE LINE AND IN THE LEFT HAND LOWER SECTION OF THE RADIATOR GRILLE.

EMBLEMS

THE HOLDEN NAME AND LOGO ON A DECORATIVE SCROLL EMBLEM IS LOCATED ON REAR OF FRONT FENDERS BELOW THE NAMEPLATE. A SQUARE CHROME EMBLEM WITH A BLACK HOLDEN EMBLEM ON A RED BACKGROUND IS CENTRALLY MOUNTED ON THE TOP CHROME GRILLE SURROUND.

Issued: JUNE, 1977 Revised:

HOLDEN 'HZ' FEATURES

STYLING - EXTERIOR

PREMIER SEDAN

PREMIER NAMEPLATE

THE PREMIER NAME IS LOCATED IN THE CENTRE OF THE REAR COMPARTMENT LID.

REAR BUMPER BAR

REAR BUMPER BAR IS DEEP SECTION WITH HORIZONTAL RUBBER STRIPS EITHER SIDE OF LICENCE PLATE DEPRESSION. VERTICAL CHROMED BUMPER GUARDS WITH RUBBER STRIPS ARE LOCATED ON BUMPER BAR EITHER SIDE OF LICENCE PLATE.

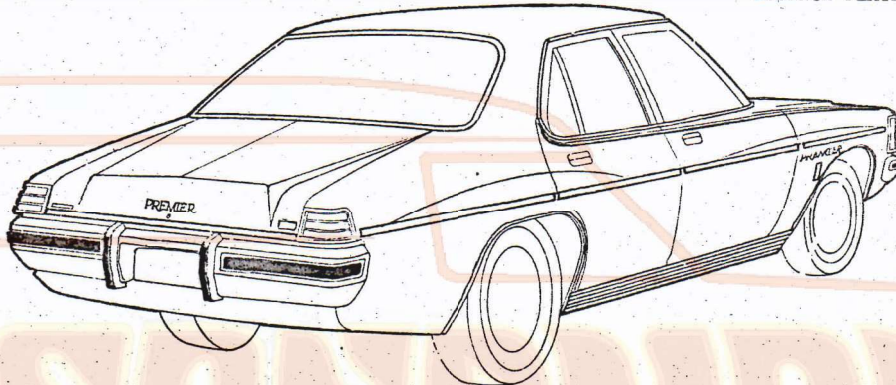

TAIL LAMPS

TAIL LAMPS ARE HORIZONTALLY MOUNTED ON REAR QUARTER PANELS. THEY ARE RECTANGULAR WRAP-AROUND ONE PIECE ASSEMBLIES COMPRISING AN UPPER STOP / TAIL LAMP AND A LOWER TURN SIGNAL / BACK-UP LAMP. A BRIGHT RIM WITH TWO BRIGHT HORIZONTAL RIBS IS FEATURED.

BADGES

AN ENGINE IDENTIFICATION BADGE IS FITTED TO THE LOWER RIGHT HAND SIDE OF THE REAR COMPARTMENT LID WHEN A 5.0L V8 ENGINE IS FITTED.

'RTS' RADIAL TUNED SUSPENSION BADGE

A RECTANGULAR BADGE TO HIGHLIGHT THE IMPROVED SUSPENSION SYSTEM IS FITTED TO THE LOWER LEFT HAND SIDE OF THE REAR COMPARTMENT LID.

BODY MOULDINGS

A WIDE STAINLESS STEEL MOULDING WITH A BLACK VINYL INSERT RETAINED BY PLASTIC CLIPS EXTENDS FULL LENGTH ON BODY WIDE LINE. A BROAD SILVER STRIP IS FITTED TO THE LOWER EDGE OF THE REAR COMPARTMENT LID.

ROCKER PANEL & WHEEL OPENINGS

ROCKER PANEL FEATURES A FULL DEPTH RIBBED MOULDING. BRIGHT MOULDINGS ARE FITTED TO FRONT AND REAR WHEEL OPENINGS.

COACH LINE STRIPING

A THICK AND THIN COLOUR CODED STRIPE EXTENDS FROM THE TIP OF THE FRONT FENDER TO THE REAR DOOR OPENING FOLLOWING THE LINE OF THE FRONT FENDER UPPER EDGE.

Issued: JUNE, 1977 ■ Revised: JULY, 1978

HOLDEN 'H2' FEATURES

STYLING - EXTERIOR

PREMIER STATION SEDAN

THE PREMIER STATION SEDAN HAS THE SAME FRONTAL APPEARANCE AS THE SEDAN. UPPER AND LOWER BODY MOULDINGS ARE ALSO SIMILAR WITH THE ADDITION OF BRIGHT MOULDINGS ON THE REAR BODY LOCK PILLAR AND REAR QUARTER WINDOWS.

ENDGATE DECORATION

BRIGHT REVEAL MOULDINGS ARE FITTED AROUND THE END GATE GLASS OPENING.

REAR NAMEPLATE

A PREMIER BADGE IS MOUNTED IN THE CENTRE OF THE ENDGATE

BADGES

AN ENGINE IDENTIFICATION BADGE IS FITTED ON THE RIGHT HAND SIDE OF THE END GATE WHEN A 5.0L V8 ENGINE IS FITTED.

'RTS' RADIAL TUNED SUSPENSION BADGE

A RECTANGULAR BADGE TO HIGHLIGHT THE IMPROVED SUSPENSION SYSTEM IS FITTED TO THE LEFT HAND SIDE OF THE ENDGATE ABOVE THE WIDE LINE.

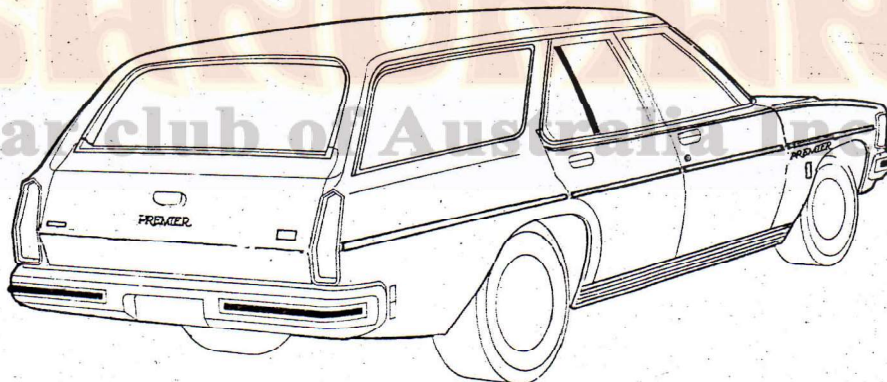

REAR BUMPER AND LIGHTS

THE REAR BUMPER BAR IS DEEP SECTION WITH HORIZONTAL RUBBER STRIPS EITHER SIDE OF LICENCE PLATE DEPRESSION. THE TAIL LAMPS ARE MOUNTED VERTICALLY IN THE REAR QUARTER PANELS ABOVE THE BUMPER BAR. THE UPPER SECTION OF THE LAMPS ARE STOP / TAIL WITH THE BOTTOM SECTION BEING TURN SIGNAL / BACK-UP. THE TAIL LAMP LENSES WITH SILVER RIBS ARE SURROUNDED BY BRIGHT DIE CAST REVEAL MOULDINGS, SIDE MARKER LAMPS ARE MOUNTED IN REAR QUARTER PANELS. WHILST THE LICENCE PLATE IS ALSO FITTED IN THE CENTRAL BUMPER DEPRESSION.

Issued: JUNE, 1977 ■ Revised: JULY, 1978

HOLDEN 'H2' FEATURES

STYLING - EXTERIOR

■ GTS

RADIATOR GRILLE

THE RADIATOR GRILLE IS A ONE PIECE MATT BLACK PLASTIC MOULDING WITH A BAR PATTERN SIMILAR TO THE PREMIER GRILLE. A BRIGHT MOULDING SURROUNDS THE GRILLE.

FRONT BUMPER BAR

THE BUMPER BAR IS PAINTED BODY COLOUR WITH A BLACK HORIZONTAL RUBBER RUB STRIP.

HEADLAMPS & BEZELS

HEADLAMPS ARE DUAL 5 $\frac{3}{4}$ " QUARTZ HALOGEN UNITS WITH BRIGHT OUTER RIMS. ALL 4 LAMPS ARE QUARTZ HALOGEN UNITS WITH LONG RANGE INNER PENCIL BEAM HI-BEAM LAMPS.

FRONT FENDER DUCTS

THREE HORIZONTAL DUCTS ARE FEATURED IN THE FRONT FENDERS TO THE REAR OF THE WHEEL ARCH.

AIR DAM

A BODY COLOURED AIR DAM IS STANDARD EQUIPMENT.

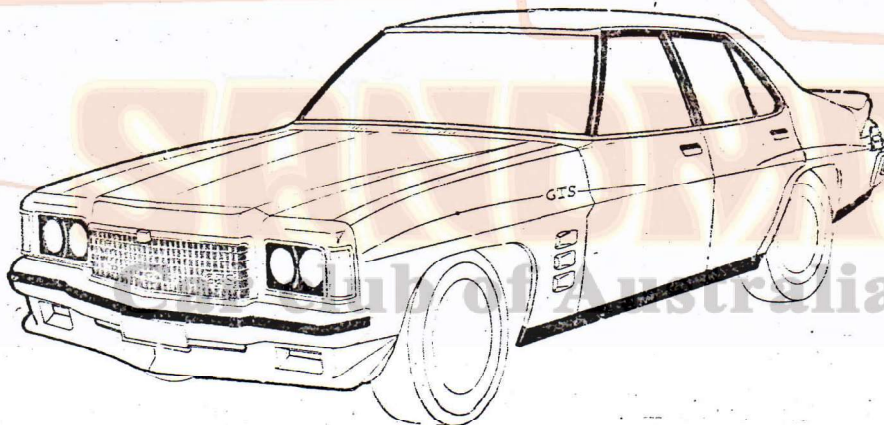

BADGES

A GTS BADGE IS LOCATED IN THE LEFT HAND LOWER SECTION OF THE RADIATOR GRILLE AND ON THE REAR OF THE FRONT FENDERS ABOVE THE BODY WIDE LINE.

FRONT & SIDE PAINT TREATMENT

LOWER SECTION OF DOORS, SIDE GLASS FRAMES, FRAME OPENINGS AND REAR QUARTER PANELS FEATURE LOW GLOSS BLACK PAINTOUTS.

MIRRORS

A STREAMLINED MIRROR PAINTED IN BODY COLOUR IS MOUNTED ON EACH FRONT DOOR.

EMBLEM

A SQUARE CHROME EMBLEM WITH A BLACK HOLDEN EMBLEM ON A RED BACKGROUND IS CENTRALLY MOUNTED ON THE TOP CHROME GRILLE SURROUND.

FRONT TURN SIGNAL & PARKING LAMPS

THESE ARE OF RECTANGULAR WRAP-AROUND DESIGN VERTICALLY MOUNTED IN UPPER LEADING EDGES OF FRONT FENDERS. AN OUTER CLEAR LENS ENCLOSES AN INNER AMBER TURN SIGNAL LAMP IN THE LOWER SECTION. A BRIGHT RIM SURROUNDS THE LAMP.

Issued: JUNE, 1977 ■ Revised: OCTOBER, 1977

HOLDEN 'HZ' FEATURES

STYLING - EXTERIOR

G T S

REAR BUMPER BAR

THE BUMPER BAR IS PAINTED BODY COLOUR WITH A HORIZONTAL BLACK RUBBER BUMP STRIP.

BADGES

- A GTS BADGE IS LOCATED IN THE CENTRE OF THE REAR COMPARTMENT LID.

MOULDINGS

REAR WINDOW SURROUND. DRIP GUTTER AND BELT LINE MOULDINGS ARE BRIGHT CHROME.

'RTS RADIAL TUNED SUSPENSION BADGE
A RECTANGULAR BADGE TO HIGHLIGHT THE IMPROVED SUSPENSION SYSTEM IS FITTED TO THE LOWER LEFT HAND SIDE OF THE REAR COMPARTMENT LID.

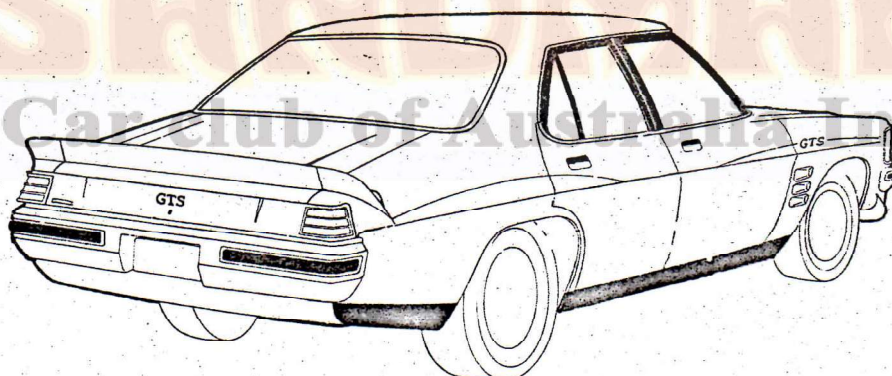

TAIL LAMPS

TAIL LAMPS ARE HORIZONTALLY MOUNTED ON REAR QUARTER PANELS. THEY ARE RECTANGULAR WRAP-AROUND ONE-PIECE ASSEMBLIES COMPRISING AN UPPER STOP/TAIL LAMP AND A LOWER TURN SIGNAL BACK-UP LAMP. RIM AND HORIZONTAL RIBS ARE PAINTED BLACK.

SPOILER

A BODY COLOURED SPOILER IS FITTED AS STANDARD ON THE REAR COMPARTMENT LID.

OPTIONAL FINISH

THICK AND THIN COLOUR CODED STRIPING MAY BE APPLIED TO THE LOWER BODY, SCULPTURED ENGINE HOOD PANEL AND REAR COMPARTMENT LID SPOILER BY THE DEALER.
FRONT AIR DAM AND REAR COMPARTMENT LID SPOILER MAY BE DELETED.
CHROME BUMPERS CAN OPTIONALLY REPLACE PAINTED BUMPERS

DOOR HANDLES

EXTERIOR DOOR HANDLES ARE MATT BLACK.

Issued: JUNE, 1977 ■ Revised: JULY, 1978

HOLDEN '82' FEATURES

STYLING - EXTERIOR

STATESMAN DEVILLE

RADIATOR GRILLE

TWO PIECE PLASTIC MOULDING WITH A CHROME SURROUND ENCLOSING 6 HORIZONTAL FINE SILVER PAINTED BARS IN THE UPPER GRILLE AND 2 IN THE LOWER GRILLE.

NAMEPLATE

DEVILLE IN BOLD SCRIPT LETTERING IS LOCATED ON THE THIRD TOP BAR ON THE LEFT SIDE

- OF THE GRILLE AND AT THE REAR OF THE FRONT FENDERS BELOW THE BODY WIDE LINE.

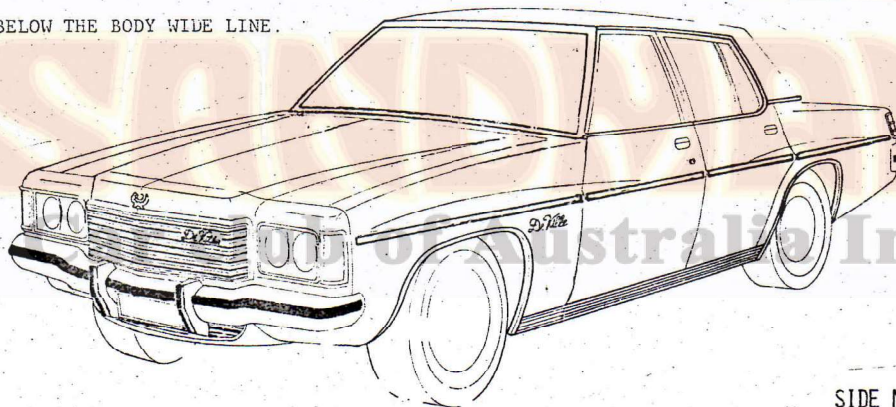

HEADLAMP & BEZELS

DUAL 5 3/4 INCH (146 mm.) QUARTZ HALOGEN UNITS ARE SET IN BRIGHT CHROME BEZELS.

FRONT TURN SIGNAL AND PARKING LAMPS

THESE ARE OF RECTANGULAR WRAP-AROUND DESIGN VERTICALLY MOUNTED IN UPPER LEADING EDGES OF FRONT FENDERS. AN OUTER CLEAR LENS ENCLOSES AN INNER AMBER TURN SIGNAL LAMP IN THE LOWER SECTION. A BRIGHT RIM SURROUNDS THE LAMP.

UPPER BODY DECORATION

UPPER BODY DECORATION CONSISTS OF BRIGHT WINDSHIELD AND REAR WINDOW REVEAL MOULDINGS, DRIP GUTTER AND DOOR BELT MOULDINGS. A DOOR BELT MOULDING IS EXTENDED ON TO THE REAR QUARTER TO FORM A BORDER FOR THE VINYL ROOF COVERING AT THE LOWER EDGE OF THE SAILPLANE. IN ADDITION BRIGHT FINISHED DOOR FRAME SCALPS ARE FITTED.

SIDE MOULDINGS

A BRIGHT FULL DEPTH RIBBED ROCKER MOULDING TOGETHER WITH BRIGHT WHEEL OPENING MOULDINGS ARE FEATURED. A WIDE STAINLESS STEEL MOULDING WITH A BLACK VINYL INSERT RETAINED BY PLASTIC CLIPS EXTENDS FULL LENGTH ON BODY WIDE-LINE.

FRONT BUMPER BAR

BUMPER BAR IS DEEP SECTION WITH HORIZONTAL RUBBER STRIP. VERTICAL CHROMED BUMPER GUARDS WITH RUBBER STRIPS ARE LOCATED ON BUMPER BAR EITHER SIDE OF THE LICENCE PLATE.

EMBLEM

A WREATH AND CREST EMBLEM IS LOCATED ON THE CENTRE OF FRONT END PANEL.

Issued: JUNE, 1977 ■ Revised: OCTOBER, 1977

HOLDEN 'HIZ' FEATURES

STYLING - EXTERIOR

STATESMAN DEVILLE

Deville SCE

TAIL LAMPS

THESE ARE VERTICALLY MOUNTED RECTANGULAR WRAPAROUND ONE PIECE ASSEMBLIES COMPRISING AN UPPER STOP / TAIL LAMP AND A LOWER TURN SIGNAL / BACK-UP LAMP. A BRIGHT RIM WITH TWO BRIGHT HORIZONTAL RIBS IS FEATURED.

ROOF COVERING

THIS MODEL FEATURES A BLACK VINYL SOFT TRIM ROOF COVERING AS STANDARD WITH A CHOICE OF TWO OPTIONAL COLOURS. A GRAINED MOULDING TO MATCH VINYL ROOF COLOUR IS FEATURED ON SAIL PLANE AT BELT LINE.

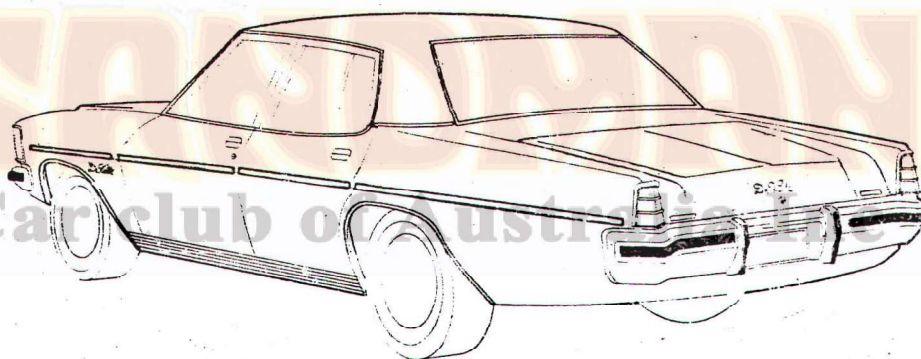

REAR NAMEPLATE

DEVILLE IN BOLT SCRIPT LETTERING IS LOCATED IN THE CENTRE OF THE REAR COMPARTMENT LID.

A RECTANGULAR STATESMAN NAMEPLATE IS LOCATED ON THE LOWER LEFT HAND EDGE OF THE COMPARTMENT LID.

'RTS' RADIAL TUNED SUSPENSION BADGE

A RECTANGULAR BADGE TO HIGHLIGHT THE IMPROVED SUSPENSION SYSTEM IS FITTED TO THE LOWER RIGHT HAND SIDE OF THE REAR COMPARTMENT LID.

REAR BUMPER BAR

REAR BUMPER BAR IS DEEP SECTION WITH HORIZONTAL RUBBER STRIPS EITHER SIDE OF LICENCE PLATE DEPRESSION. VERTICAL CHROMED BUMPER GUARDS WITH RUBBER STRIPS ARE LOCATED ON BUMPER BAR EITHER SIDE OF THE LICENCE PLATE.

WHEEL OPENINGS

BRIGHT MOULDINGS ARE FITTED TO FRONT AND REAR WHEEL OPENINGS.

HOLDEN 'HZ' FEATURES

STYLING - EXTERIOR

STATESMAN CALAIS

RADIATOR GRILLE

TWO PIECE PLASTIC MOULDING WITH A CHROME SURROUND ENCLOSING 6 HORIZONTAL FINE SILVER PAINTED BARS IN THE UPPER GRILLE AND 2 IN THE LOWER GRILLE.

NAMEPLATE

CALAIS IN BOLD SCRIPT LETTERING IS LOCATED ON THE FOURTH TOP BAR ON THE LEFT SIDE OF THE GRILLE.

UPPER BODY DECORATION

UPPER BODY DECORATION CONSISTS OF BRIGHT WINDSHIELD AND REAR WINDOW REVEAL MOULDINGS DRIP GUTTER AND DOOR BELT MOULDINGS. A DOOR BELT MOULDING IS EXTENDED ON TO THE REAR QUARTER TO FORM A BORDER FOR THE VINYL ROOF COVERING AT THE LOWER EDGE OF THE SAILPLANE. IN ADDITION BRIGHT FINISHED DOOR FRAME SCALPS ARE FITTED.

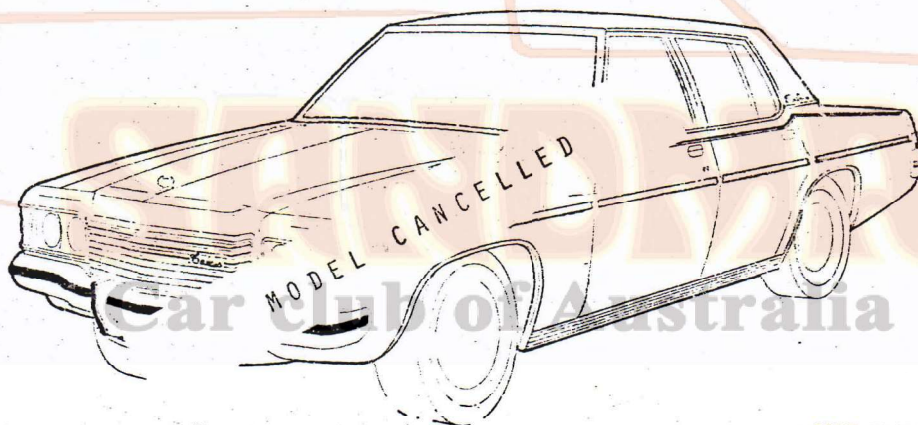

EMBLEM

A DISTINCTIVE WREATH AND CREST COLLAPSIBLE HOOD ORNAMENT IS LOCATED CENTRALLY ON THE FORWARD SECTION OF THE ENGINE HOOD.

FRONT TURN SIGNAL & PARKING LAMPS

THESE ARE OF RECTANGULAR WRAP-AROUND DESIGN VERTICALLY MOUNTED IN UPPER LEADING EDGES OF FRONT FENDERS AN OUTER CLEAR LENS ENCLOSES AN INNER AMBER TURN SIGNAL LAMP IN THE LOWER SECTION. A BRIGHT RIM SURROUNDS THE LAMP.

SIDE MOULDINGS

A BRIGHT FULL DEPTH RIBBED ROCKER MOULDING TOGETHER WITH BRIGHT WHEEL OPENING MOULDINGS ARE FEATURED. A WIDE STAINLESS STEEL MOULDING WITH A BLACK VINYL INSERT RETAINED BY PLASTIC CLIPS EXTENDS FULL LENGTH ON BODY WIDE-LINE.

FRONT BUMPER BAR

BUMPER BAR IS DEEP SECTION WITH HORIZONTAL RUBBER STRIP. VERTICAL CHROMED BUMPER GUARDS WITH RUBBER STRIPS ARE LOCATED ON BUMPER BAR EITHER SIDE OF THE LICENCE PLATE.

HEADLAMP & BEZELS

DUAL 5 3/4 INCH (146 mm.) QUARTZ HALOGEN UNITS ARE SET IN BRIGHT CHROME BEZELS.

Issued: JUNE, 1977

Revised: OCTOBER, 1977

HOLDEN 'H2' FEATURES

STYLING - EXTERIOR

STATESMAN CALAIS

TAIL LAMPS

THESE ARE VERTICALLY MOUNTED RECTANGULAR WRAP AROUND ONE PIECE ASSEMBLIES COMPRISING AN UPPER STOP/TAIL LAMP AND A LOWER TURN SIGNAL/ BACK-UP LAMP. A BRIGHT RIM WITH TWO BRIGHT HORIZONTAL RIBS IS FEATURED.

ROOF COVERING

THIS MODEL FEATURES A BLACK VINYL SOFT TRIM ROOF COVERING AS STANDARD WITH A CHOICE OF TWO OPTIONAL COLOURS.

GRAINED MOULDING TO MATCH VINYL ROOF COLOUR IS FEATURED ON SAIL PLANE AT BELT LINE.

MOULDINGS

A WIDE BRIGHT MOULDING WITH A BLACK PAINTED GROOVE BORDER EXTENDS ACROSS THE LOWER EDGE OF THE REAR COMPARTMENT LID.

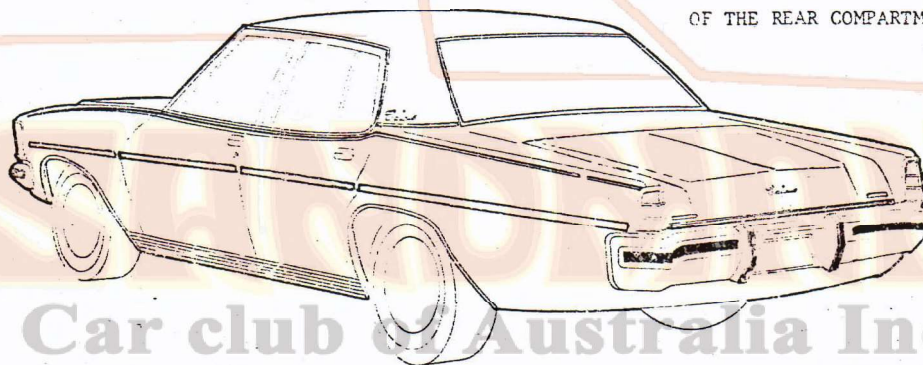

NAMEPLATES

CALAIS IN BOLD SCRIPT LETTERING IS LOCATED ON THE SAIL PLANE AND ON CENTRE OF REAR COMPARTMENT LID.

A RECTANGULAR STATESMAN NAMEPLATE IS LOCATED ON THE LOWER LEFT HAND EDGE OF THE COMPARTMENT LID.

'RTS' RADIAL TUNED SUSPENSION BADGE

A RECTANGULAR BADGE TO HIGHLIGHT THE IMPROVED SUSPENSION SYSTEM IS FITTED TO THE LOWER RIGHT HAND SIDE OF THE REAR COMPARTMENT LID.

REAR BUMPER BAR

REAR BUMPER BAR IS DEEP SECTION WITH HORIZONTAL RUBBER STRIPS EITHER SIDE OF LICENCE PLATE DEPRESSION. VERTICAL CHROMED BUMPER GUARDS WITH RUBBER STRIPS ARE LOCATED ON BUMPER BAR EITHER SIDE OF THE LICENCE PLATE.

WHEEL OPENINGS

BRIGHT MOULDINGS ARE FITTED TO FRONT AND REAR WHEEL OPENINGS.

COACHLINE

A COLOUR CODED THICK AND THIN COACHLINE EXTENDS FROM THE TIP OF THE FRONT FENDER TO THE TIP OF THE REAR FENDER FOLLOWING THE LINE OF THE FENDER UPPER EDGE.

Issued: JUNE, 1977

Revised: OCTOBER, 1977

HOLDEN 'HIZ' FEATURES

STYLING - EXTERIOR

STATESMAN CAPRICE

RADIATOR GRILLE

A TWO PIECE PLASTIC MOULDING WITH AN UPPER GRILLE OF 10 HORIZONTAL FINE SILVER BARS GROUPED IN 5 PAIRS AND A LOWER GRILLE OF ONE FINE SILVER BAR ABOVE THE BROAD SILVER BAR. A CHROME TRIM WITH A BROAD DIE CAST TOP MOULDING SURROUNDS THE GRILLE.

UPPER BODY DECORATION

UPPER BODY DECORATION CONSISTS OF BRIGHT WINDSHIELD AND REAR WINDOW REVEAL MOULDINGS TOGETHER WITH BRIGHT DRIP GUTTER AND DOOR BELT MOULDINGS.

A DOOR BELT MOULDING IS EXTENDED ON TO THE REAR QUARTER TO FORM A BORDER FOR THE VINYL ROOF COVERING AT THE LOWER EDGE OF THE SAIL PLANE. IN ADDITION BRIGHT FINISHED DOOR FRAME SCALPS ARE FITTED. COACHLINING ON THE ENGINE HOOD AND REAR COMPARTMENT HIGHLIGHT THE SCULPTURED PANELS.

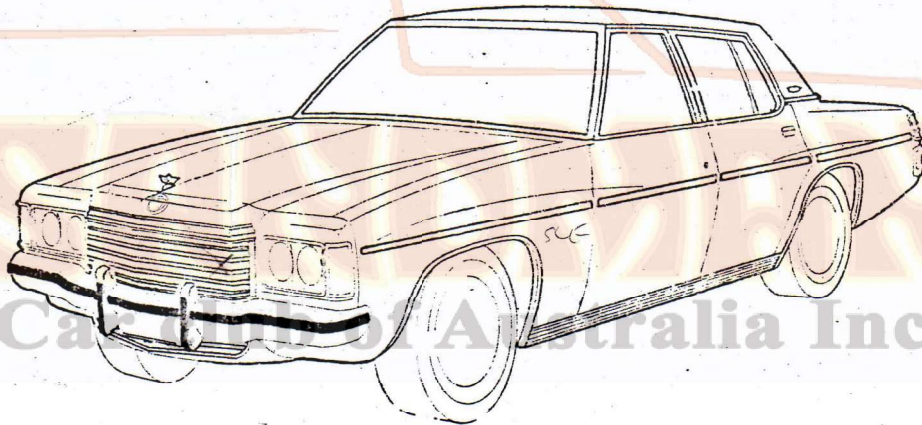

FRONT TURN SIGNAL AND PARKING LAMPS

THESE ARE OF RECTANGULAR WRAP-AROUND DESIGN VERTICALLY MOUNTED IN UPPER LEADING EDGES OF FRONT FENDERS. AN OUTER CLEAR LENS ENCLOSES AN INNER AMBER TURN SIGNAL LAMP IN THE LOWER SECTION. A BRIGHT RIM SURROUNDS THE LAMP.

SIDE MOULDINGS

A BRIGHT FULL DEPTH RIBBED ROCKER MOULDING TOGETHER WITH BRIGHT WHEEL OPENING MOULDINGS ARE FEATURED. A WIDE STAINLESS STEEL MOULDING WITH A BLACK VINYL INSERT RETAINED BY PLASTIC CLIPS EXTENDS FULL LENGTH ON BODY WIDE LINE.

FRONT BUMPER BAR

FRONT BUMPER BAR IS DEEP SECTION WITH A HORIZONTAL RUBBER STRIP. VERTICAL CHROMED BUMPER GUARDS WITH RUBBER STRIPS ARE LOCATED ON BUMPER BAR EITHER SIDE OF THE LICENCE PLATE.

EMBLEM

A DISTINCTIVE CAPRICE COLLAPSIBLE HOOD ORNAMENT IS LOCATED CENTRALLY ON THE FORWARD SECTION OF THE ENGINE HOOD.

HEADLAMPS & BEZELS

THESE ARE DUAL 5 3/4 INCH (146 mm) QUARTZ HALOGEN UNITS SET IN BRIGHT BEZELS.

WHEEL OPENINGS

BRIGHT MOULDINGS ARE FITTED TO THE FRONT AND REAR WHEEL OPENINGS.

Issued: JUNE, 1977

Revised:

HOLDEN 'HZ' FEATURES

STYLING- EXTERIOR

STATESMAN CAPRICE

TAIL LAMPS

THESE ARE VERTICALLY MOUNTED RECTANGULAR WRAP-AROUND ONE PIECE ASSEMBLIES COMPRISING AN UPPER STOP / TAIL LAMP AND LOWER TURN SIGNAL / BACK-UP LAMP. A BRIGHT RIM WITH TWO BRIGHT HORIZONTAL RIBS IS FEATURED.

ROOF COVERING

THIS MODEL FEATURES A BLACK VINYL SOFT TRIM ROOF COVERING AS STANDARD WITH A CHOICE OF FIVE OPTIONAL COLOURS. A GRAINED MOULDING TO MATCH VINYL ROOF COLOUR IS FEATURED ON SAIL PLANE AT BELT LINE.

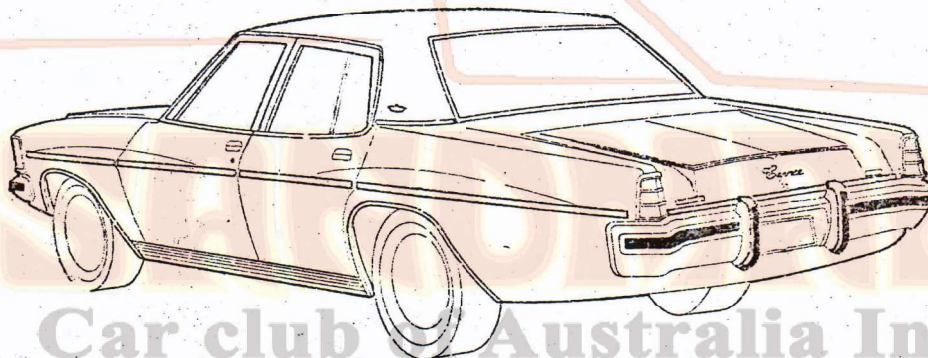

REAR NAMEPLATE

CAPRICE IN BOLD SCRIPT LETTERING IS LOCATED IN THE CENTRE OF THE REAR COMPARTMENT LID. A RECTANGULAR STATESMAN NAME-PLATE IS LOCATED ON THE LOWER LH SIDE OF THE REAR COMPARTMENT LID.

EMBLEMS

CAPRICE EMBLEMS ARE LOCATED ON SAILPLANE

REAR BUMPERS

BUMPER BAR IS DEEP SECTION WITH A BLACK HORIZONTAL RUBBER STRIP. VERTICAL CHROMED BUMPER GUARDS WITH MATCHING RUBBER STRIPS ARE LOCATED ON BUMPER BAR EITHER SIDE OF THE LICENCE PLATE.

MOULDINGS

A WIDE BRIGHT MOULDING WITH A BLACK PAINTED GROOVE BORDER EXTENDS ACROSS THE LOWER EDGE OF THE REAR COMPARTMENT LID.

'RTS' RADIAL TUNED SUSPENSION BADGE

A RECTANGULAR BADGE TO HIGHLIGHT THE IMPROVED SUSPENSION SYSTEM IS FITTED TO THE LOWER RIGHT HAND SIDE OF THE REAR COMPARTMENT LID.

Issued: JUNE, 1977

Revised:

HOLDEN '82' FEATURES

STYLING - EXTERIOR

SANDMAN

FRONTAL APPEARANCE

A MATT BLACK PLASTIC GRILLE DUAL QUARTZ HALOGEN HEADLAMPS AND A BODY COLOURED AIR DAM THE SAME AS MONARO GTS ARE FEATURES OF THE FRONT END APPEARANCE.

PAINT TREATMENT

ROCKER PANEL SIDE GLASS FRAMES, FRAME OPENINGS, REAR QUARTER PANELS, WINDSCREEN FRAME, DOOR HANDLES AND TAIL GATE WINDOW SURROUND FEATURE LOW GLOSS BLACK PAINTOUTS.

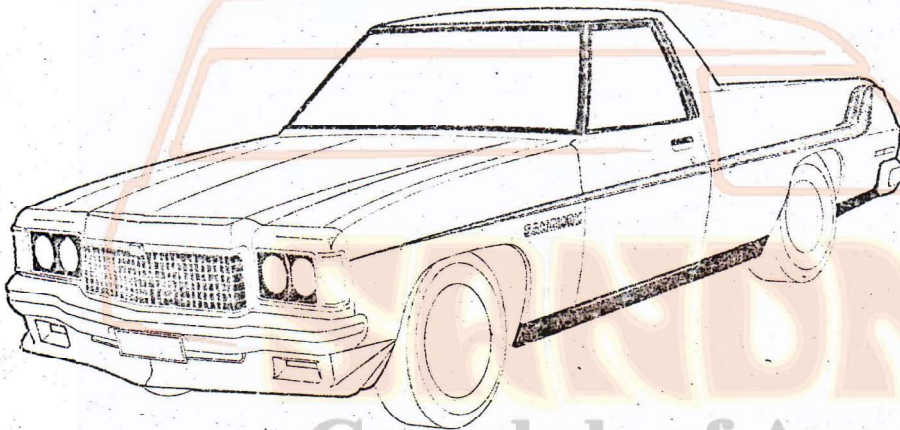

RTS RADIAL TUNED SUSPENSION BADGE

AN 'RTS' (RADIAL TUNED SUSPENSION) BADGE IS FITTED ON THE LEFT HAND SIDE OF THE TAILGATE BELOW THE BODY WIDE LINE.

BUMPER BARS

FRONT BUMPER IS CHROME PLATED DEEP SECTION WITH HORIZONTAL RECESS.

REAR PROTECTION IS BY CHROME PLATED BUMPERETTES.

IDENTIFICATION DECALS

A COLOUR KEYED DECORATIVE FLASH EXTENDS FULL LENGTH ON THE SIDE ABOVE THE BODY WIDE LINE. 'SANDMAN' IN COLOUR MATCHED POP-ART TYPE LETTERING EXTENDS FULL WIDTH ACROSS THE TAIL GATE AND IN SMALLER SIZE AT THE REAR OF THE FRONT WHEEL ARCH.

MIRRORS

A STREAMLINED BODY COLOURED MIRROR IS MOUNTED ON EACH FRONT DOOR.

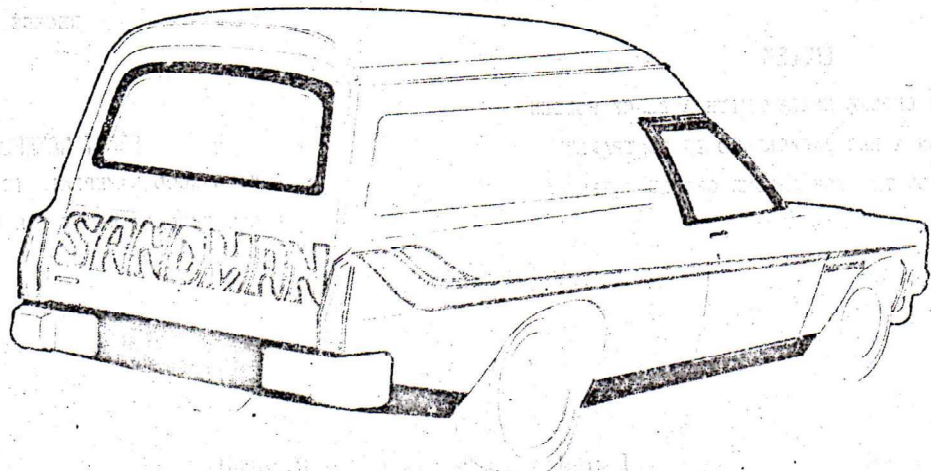

Issued: JUNE, 1977

Revised:

HOLDEN 'HZ' FEATURES

STYLING- EXTERIOR

KINGSWOOD UTILITY

RADIATOR GRILLE

ONE PIECE PLASTIC MOULDING WITH A CHROME SURROUND ENCLOSING 17 VERTICAL AND 5 HORIZONTAL BARS FORMING A MESH TYPE GRILLE OF HORIZONTALLY ALIGNED RECTANGULAR SECTIONS.

UPPER BODY DECORATION

BRIGHT REVEAL MOULDINGS AROUND THE WINDSHIELD TOGETHER WITH BRIGHT DRIP GUTTER AND BODYLOCK PILLAR MOULDINGS ARE FITTED. THE REAR WINDOW SURROUND FEATURES A BRIGHT INSERT.

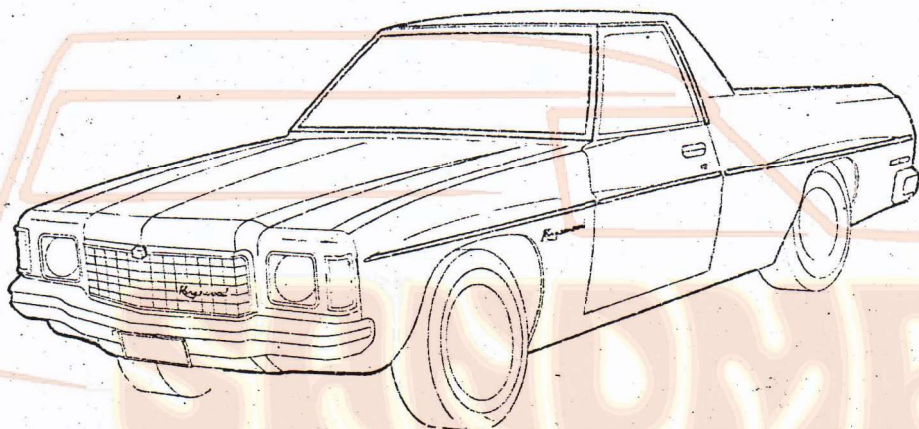

Car club of Australia Inc

FRONT TURN SIGNAL AND PARKING LAMPS

THESE ARE OF RECTANGULAR WRAP-AROUND DESIGN VERTICALLY MOUNTED IN UPPER LEADING EDGES OF FRONT FENDERS. AN OUTER CLEAR LENS ENCLOSES AN INNER AMBER TURN SIGNAL LAMP IN THE LOWER SECTION. A BRIGHT RIM SURROUNDS THE LAMP.

HEADLAMPS & BEZELS

HEADLAMPS ARE SINGLE 7 INCH (178mm) TUNGSTEN FILAMENT SEALED BEAM RECESSED IN GREY PAINTED BEZELS HAVING BRIGHT RIMS.

FRONT BUMPER BAR

BUMPER BAR IS DEEP SECTION WITH HORIZONTAL RECESS.

EMBLEM

A SQUARE CHROME EMBLEM WITH A BLACK HOLDEN EMBLEM ON A RED BACKGROUND IS CENTRALLY MOUNTED ON THE TOP CHROME GRILLE SURROUND.

FRONT NAMEPLATE

A KINGSWOOD NAMEPLATE IS LOCATED ON REAR OF FRONT FENDERS BELOW THE BODY WIDE MINE:

Issued: JUNE, 1977 Revised:

HOLDEN 'HZ' FEATURES

STYLING - EXTERIOR

KINGSWOOD UTILITY

REAR BUMPER AND LIGHTS

REAR END PROTECTION CONSISTS OF BUMPERETTES.
TAIL LAMPS ARE MOUNTED VERTICALLY IN THE REAR
QUARTER PANELS ABOVE THE BUMPERETTES WITH
BRIGHT FINISHED DIE CAST REVEAL MOULDINGS.
THE UPPER SECTIONS OF THE LAMPS ARE STOP/TAIL
WITH THE BOTTOM SECTIONS BEING TURN SIGNAL /
BACK-UP. SIDE MARKER LAMPS ARE LOCATED IN
REAR QUARTER PANELS.

ENDGATE DECORATION

A WIDE ALUMINIUM MOULDING WITH A
BLACK VINYL INSERT RETAINED BY PLASTIC
CLIPS EXTENDS FULL WIDTH ON BODY WIDE LINE.

TONNEAU COVER

A LASH-ON TONNEAU COVER IS FITTED AS STANDARD
EQUIPMENT ON THIS MODEL.



BADGES

AN ENGINE IDENTIFICATION BADGE IS FITTED ON
THE RIGHT HAND SIDE OF THE TAILGATE ABOVE
THE FULL WIDTH MOULDING.

BODY MOULDINGS

AN ALUMINIUM MOULDING WITH A BLACK
VINYL INSERT RETAINED BY PLASTIC CLIPS EXTENDS
FULL LENGTH ON BODY WIDE LINE.

REAR NAMEPLATE

A KINGSWOOD NAMEPLATE IS LOCATED
IN THE CENTRE OF THE ENDGATE
ABOVE THE FULL WIDTH MOULDING.

'RTS' RADIAL TUNED SUSPENSION BADGE

A RECTANGULAR BADGE TO HIGHLIGHT THE IMPROVED SUSPENSION SYSTEM
IS FITTED TO THE LEFT HAND SIDE OF THE ENDGATE ABOVE THE WIDE LINE.

Issued: JUNE, 1977 Revised:

HOLDEN 'HIZ' FEATURES

STYLING - EXTERIOR

KINGSWOOD PANEL VAN

THE KINGSWOOD PANEL VAN HAS THE SAME FRONT END APPEARANCE AS THE UTILITY.

REAR BUMPER AND LIGHTS

REAR END PROTECTION CONSISTS OF BUMPERETTES.
TAIL LAMPS ARE MOUNTED VERTICALLY IN THE REAR
QUARTER PANELS ABOVE THE BUMPERETTES WITH
BRIGHT FINISHED DIE CAST REVEAL MOULDINGS.
THE UPPER SECTIONS OF THE LAMPS ARE STOP/TAIL
WITH THE BOTTOM SECTIONS BEING TURN SIGNAL /
BACK-UP. SIDE MARKER LAMPS ARE LOCATED IN
REAR QUARTER PANELS.

ENDGATE DECORATION

AN ALUMINIUM MOULDING WITH A BLACK
VINYL INSERT RETAINED BY PLASTIC CLIPS
EXTENDS FULL WIDTH ON BODY WIDE LINE.

REAR NAMEPLATE

A KINGSWOOD NAMEPLATE IS LOCATED IN THE
CENTRE OF THE ENDGATE ABOVE THE FULL WIDTH
MOULDING.

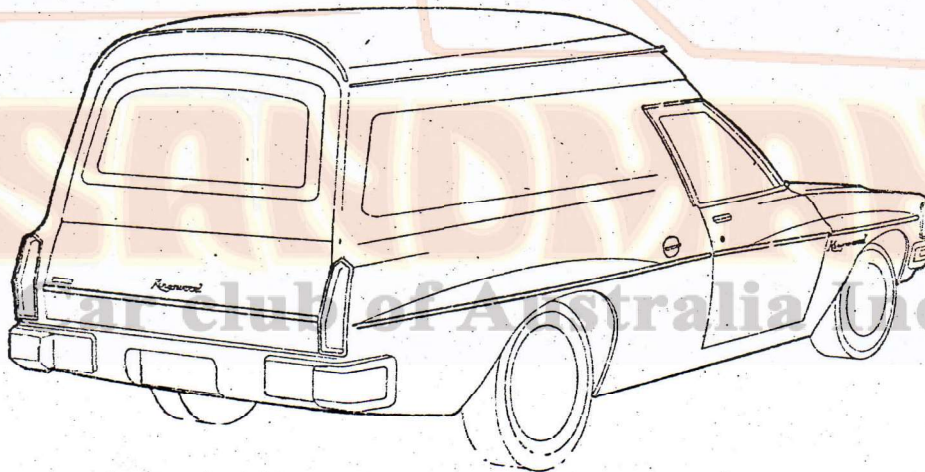

BADGES

AN ENGINE IDENTIFICATION BADGE IS FITTED ON
THE RIGHT HAND SIDE OF THE TAILGATE ABOVE THE
FULL WIDTH MOULDING WHEN A V8 IS FITTED.

BODY MOULDINGS

A NEW WIDE ALUMINIUM MOULDING WITH A
BLACK VINYL INSERT RETAINED BY PLASTIC
CLIPS EXTENDS FULL LENGTH ON BODY WIDE
LINE.

'RTS' RADIAL TUNED SUSPENSION BADGE

A RECTANGULAR BADGE TO HIGHLIGHT THE IMPROVED SUSPENSION SYSTEM
IS FITTED TO THE LEFT HAND SIDE OF THE ENDGATE ABOVE THE WIDE LINE.

Issued: JUNE, 1977 Revised:

HOLDEN 'HZ' FEATURES

STYLING - EXTERIOR

HOLDEN UTILITY

RADIATOR GRILLE

ONE PIECE PLASTIC MOULDING WITH A CHROME SURROUND ENCLOSING 17 VERTICAL AND 5 HORIZONTAL BARS FORMING A MESH TYPE GRILLE OF HORIZONTALLY ALIGNED RECTANGULAR SECTIONS.

UPPER BODY DECORATION

A BRIGHT FINISHED REVEAL MOULDING IS FEATURED AROUND THE WINDSHIELD.



FRONT TURN SIGNAL AND PARKING LAMPS

THESE ARE OF RECTANGULAR WRAP-AROUND DESIGN VERTICALLY MOUNTED IN UPPER LEADING EDGES OF FRONT FENDERS. AN OUTER CLEAR LENS ENCLOSES AN INNER AMBER TURN SIGNAL LAMP IN THE LOWER SECTION. A BRIGHT RIM SURROUNDS THE LAMP.

HEADLAMPS AND BEZELS

HEADLAMPS ARE SINGLE 7 INCH (178mm) TUNGSTEN FILAMENT SEALED BEAM UNITS RECESSED IN GREY PAINTED BEZELS HAVING BRIGHT RIMS.

EMBLEM

A SQUARE CHROME EMBLEM WITH A BLACK HOLDEN EMBLEM ON A RED BACKGROUND IS CENTRALLY MOUNTED ON THE TOP CHROME GRILLE SURROUND.

FRONT BUMPER BAR

BUMPER BAR IS DEEP SECTION WITH HORIZONTAL RECESS.

Issued: JUNE, 1977 Revised:

HOLDEN 'H2' FEATURES

STYLING - EXTERIOR

HOLDEN UTILITY

REAR BUMPER AND LIGHTS

REAR END PROTECTION CONSISTS OF BUMPERETTES.

TAIL LAMPS ARE MOUNTED VERTICALLY IN THE REAR QUARTER PANELS ABOVE THE BUMPERETTES WITH DIE CAST SURROUNDS IN BODY COLOUR.

THE UPPER SECTIONS OF THE LAMPS ARE STOP / TAIL WITH THE BOTTOM SECTIONS BEING TURN SIGNAL / BACK-UP. SIDE MARKER LAMPS ARE LOCATED IN REAR QUARTER PANELS.

REAR NAMEPLATE

A HOLDEN NAMEPLATE IS LOCATED IN THE CENTRE OF THE ENDGATE.

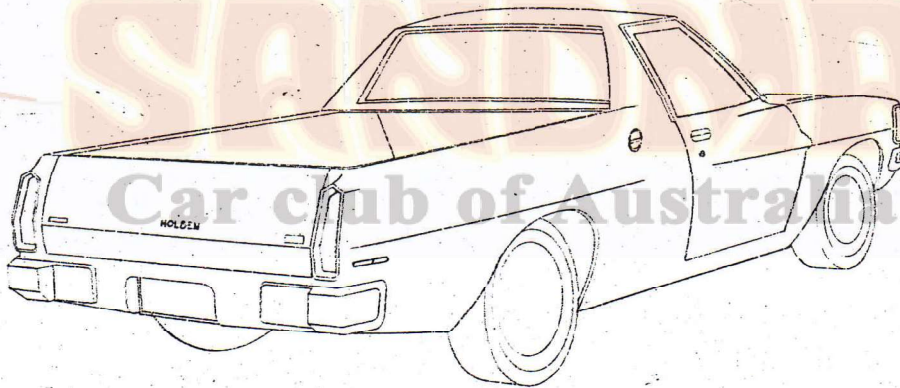

BADGES

AN IDENTIFICATION BADGE IS FITTED ON THE RIGHT HAND SIDE OF THE ENDGATE AT THE BODY WIDE LINE WHEN A V8 ENGINE IS FITTED.

'RTS' RADIAL TUNED SUSPENSION BADGE

A RECTANGULAR BADGE TO HIGHLIGHT THE IMPROVED SUSPENSION SYSTEM IS FITTED TO THE LEFT HAND SIDE OF THE ENDGATE ABOVE THE WIDE LINE.

Issued: JUNE, 1977 Revised:

HOLDEN 'HIZ' FEATURES

STYLING - EXTERIOR

HOLDEN PANEL VAN

REAR NAMEPLATE

A HOLDEN NAMEPLATE IS LOCATED
IN THE CENTRE OF THE TAILGATE.

THE HOLDEN PANEL VAN HAS
THE SAME FRONTAL APPEARANCE
AS THE UTILITY MODEL.

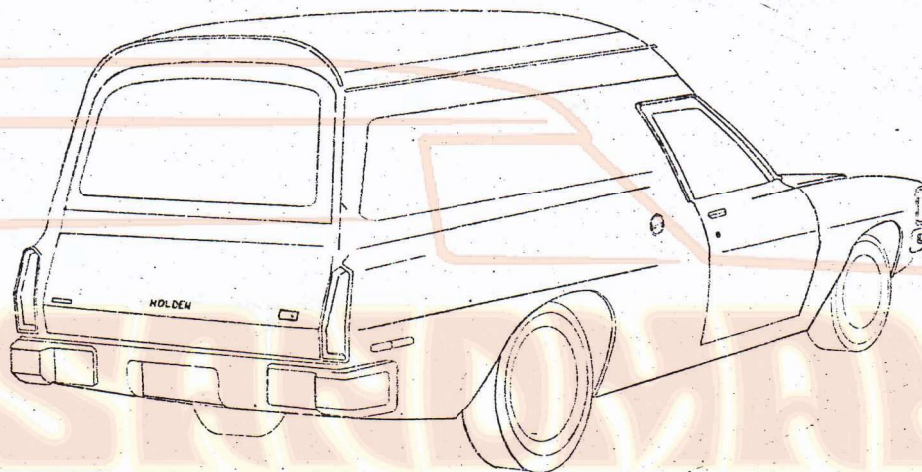

Car club of Australia Inc

REAR BUMPER AND LIGHTS

REAR END PROTECTION CONSISTS OF BUMPERETTES.
TAIL LAMPS ARE MOUNTED VERTICALLY IN THE REAR
QUARTER PANELS ABOVE THE BUMPERETTES WITH DIE
CAST SURROUNDS IN BODY COLOUR.
THE UPPER SECTIONS OF THE LAMPS ARE STOP / TAIL
WITH THE BOTTOM SECTIONS BEING TURN SIGNAL /
BACK UP, SIDE MARKER LAMPS ARE LOCATED IN REAR
QUARTER PANELS.

BADGES

AN IDENTIFICATION BADGE IS FITTED ON THE RIGHT HAND SIDE OF THE ENDGATE AT THE BODY WIDE
LINE WHEN A V8 ENGINE IS FITTED.

'RTS' RADIAL TUNED SUSPENSION BADGE

A RECTANGULAR BADGE TO HIGHLIGHT THE IMPROVED SUSPENSION SYSTEM IS FITTED TO THE LEFT HAND
SIDE OF THE ENDGATE ABOVE THE WIDE LINE.

Issued: JUNE, 1977 Revised:

HOLDEN 'HZ' FEATURES

STYLING - EXTERIOR

HOLDEN CHASSIS & CAB

RADIATOR GRILLE

THE CHASSIS AND CAB GRILLE IS A ONE
PIECE STEEL PRESSING WITH SILVER
PAINTED FINISH

HEADLAMPS

HEADLAMPS INCORPORATING PARKING LAMPS
ARE SINGLE 7 INCH (178mm) TUNGSTEN FILAMENT
SEALED BEAM UNITS RECESSED IN GREY PAINTED BEZELS
HAVING BRIGHT RIMS.

UPPER BODY DECORATION

A BRIGHT FINISH REVEAL MOULDING IS
FITTED AROUND THE WINDSHIELD.

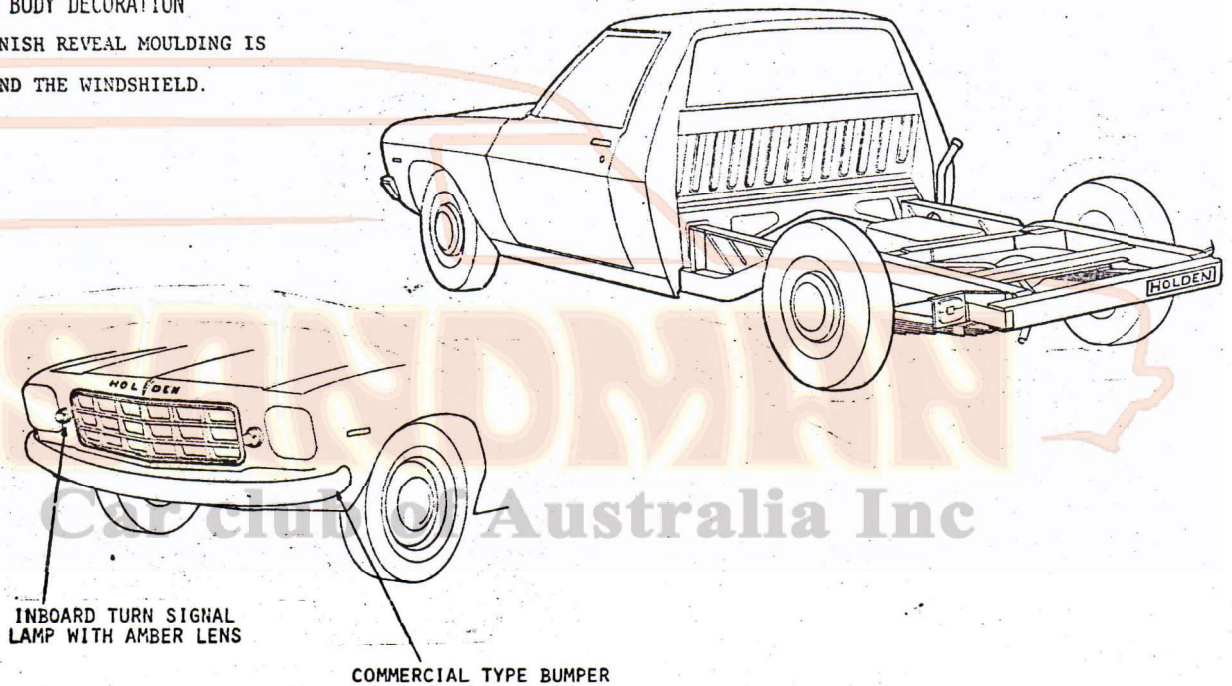

INBOARD TURN SIGNAL
LAMP WITH AMBER LENS

COMMERCIAL TYPE BUMPER

NAMEPLATES

A HOLDEN NAME TRANSFER IS LOCATED AT THE REAR ON
THE RIGHT SIDE OF THE FRAME CROSSMEMBER.
INDIVIDUAL HOLDEN NAME LETTERS ARE FEATURED ON THE
RADIATOR GRILLE FRONT PANEL.

REAR LIGHTS

UNIVERSAL TYPE STOP / TAIL AND TURN
SIGNAL / BACK-UP LAMPS ARE ATTACHED
TO THE FRAME. THE REAR LICENCE PLATE
LIGHT AND BRACKET IS LOCATED ON THE
RIGHT SIDE OF THE FRAME.

BUMPERS, HUBCAPS & WHEELS

THE FRONT BUMPER, HUBCAPS AND WHEELS
ARE PAINTED SILVER.

'RTS' RADIAL TUNED SUSPENSION BADGE

A RECTANGULAR BADGE TO HIGHLIGHT THE IMPROVED
SUSPENSION SYSTEM IS FITTED TO THE FRONT FENDER
FORWARD OF THE WHEEL ARCH.

Issued: JUNE, 1977

Revised:

HOLDEN 'HZ' FEATURES

STYLING - EXTERIOR

WHEEL DECORATIONS

BELMONT KINGSWOOD HOLDEN CHASSIS & CAB

THE HUB CAP IS STYLED TO SHOW 2 RAISED RINGS SEPARATED BY A BLACK RING.

THE CENTRE IS A FLAT LARGE DEPRESSION WITH A CENTRAL 'GMH' LION EMBLEM IN BLACK.

THE CHASSIS AND CAB MODEL USES THE SAME HUB CAP FINISHED IN SILVER PAINT INSTEAD OF CHROME AND BLACK.



KINGSWOOD SL

THE 'KINGSWOOD SL' WHEEL COVER IS AN ALUMINIUM PRESSING WITH AN OUTER BORDER OF 36 SHORT RADIAL SLOTS.

THE CENTRE CONSISTS OF A BRIGHT SLIGHTLY CONVEX SECTION WITH A BEVELLED OUTER EDGE.

A HOLDEN LION EMBLEM ON A NEW BLACK SHIELD BACKGROUND IS LOCATED CENTRALLY.

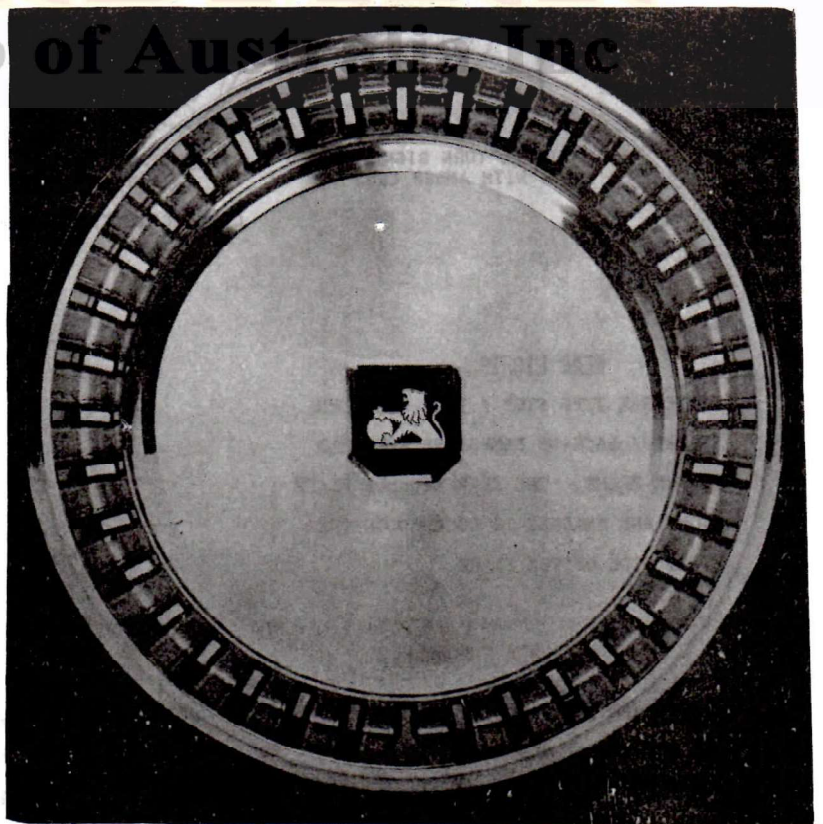

Issued: JUNE, 1977

Revised:

HOLDEN 'HZ' FEATURES

STYLING - EXTERIOR

WHEEL DECORATIONS

PREMIER

THE PREMIER WHEEL COVER IS A BRIGHT PRESSING WITH AN OUTER BORDER OF 90 SHORT RADIAL SLOTS. A SMOOTH CONCAVE SECTION JOINS THE SLOTS TO A PROJECTING CIRCULAR CENTRE BOSS CONTAINING A 'GMH' LION EMBLEM. THE CENTRE BOSS DECORATION CONSISTS OF A NARROW BLACK PAINTED RING SURROUNDING A BRIGHT LION EMBLEM ON A BLACK FIELD.

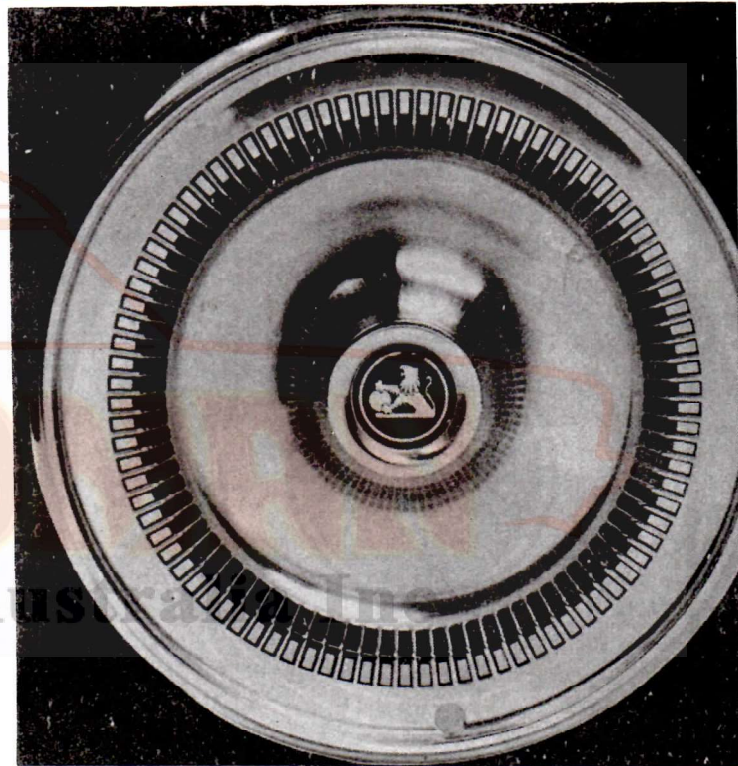

GTS AND SANDMAN

THE WHEEL DISC FOR MONARO GTS AND SANDMAN IS A FIVE SPOKE DESIGN OF PRESSED STEEL.

FOR GTS THE INNER PORTION OF THE DISC IS PAINTED BLACK WITH BODY COLOUR ON THE RIM AND OUTER SURFACE OF THE SPOKES.

FOR SANDMAN THE INNER PORTION OF THE DISC IS PAINTED BLACK WITH A SILVER RIM WHICH CARRIES THROUGH TO THE OUTER SURFACE OF THE SPOKES.

HUB CENTRES ARE CHROME PLATED WITH A CHROME HOLDEN LION EMBLEM ON A BLACK BACKGROUND.

DOMED TYPE CHROME PLATED WHEEL NUTS ARE A VISIBLE FEATURE.

A CHROME PLATED RIM MOUNTED TRIM RING IS A STANDARD FITMENT TO GIVE A DEEP DISHED EFFECT.



Issued: JULY, 1977

Revised:

HOLDEN 'HZ' FEATURES

STYLING - EXTERIOR

WHEEL DECORATIONS

STATESMAN DEVILLE

THE DEVILLE WHEEL COVER FEATURES A CHROME OUTER BAND AND 4 FINE SILVER CONCENTRIC RINGS ON A BLACK BACK GROUND SURROUNDING A SILVER CIRCULAR CENTRE SECTION. THE CENTRE CONTAINS A SILVER MONOTONE STATESMAN LAUREL WREATH AND GMH HERALDIC SHIELD EMBLEM ON A LARGE DIAMETER BLACK BACKGROUND WITH A THIN BORDER RING.



STATESMAN CALAIS

THE CALAIS WHEEL COVER FEATURES A CHROME OUTER BAND AND 3 FINE SILVER CONCENTRIC RINGS SURROUNDING A SILVER CIRCULAR CENTRE SECTION.

THE CENTRE CONTAINS A COLOURED RAISED STATESMAN LAUREL WREATH AND GMH HERALDIC SHIELD EMBLEM ON A SMALL DIAMETER BLACK FIELD WITH A THICK BORDER RING.

Issued: JULY, 1977

Revised:

HOLDEN 'HZ' FEATURES

STYLING - INTERIOR

INDEX TO SECTION C

INTRODUCTION	C - 1
SANDMAN, KINGSWOOD AND HOLDEN COMMERCIALS	C - 2, C - 3
KINGSWOOD (A9K)	C - 4, C - 5
KINGSWOOD SL	C - 6, C - 7
PREMIER	C - 8, C - 9
MONARO GTS	C - 10, C - 11
STATESMAN DEVILLE AND CALAIS	C - 12, C - 13
STATESMAN CAPRICE	C - 14, C - 15
STEERING COLUMN MULTI FUNCTION	C - 16
WARNING LAMPS GAUGES AND CONTROLS	C - 17

Issued: JUNE 1977

Revised:

INDEX

HOLDEN 'HZ' FEATURES

STYLING - INTERIOR

INTRODUCTION

THE 'HZ' INTERIOR IS SIMILAR TO THE PREVIOUS 'HX' WITH THE FOLLOWING NEW FEATURES.

GTS DOOR TRIMS ARE NOW COMMON WITH THE PREMIER MODEL.

OPTIONAL TRIM MATERIAL ON GTS IS PLAID CLOTH, ALSO VELOUR HEADLINING IS OPTIONAL ON CAPRICE.

COMMERCIAL VEHICLE SEATING IS IMPROVED WITH THE ADDITION OF A CENTRE FOLD DOWN ARMREST TO THE BENCH SEAT.

THE NEW KINGSWOOD 'SL' MODEL IS FITTED WITH BUCKET FRONT SEATS, HIGH ARMREST SEAT DIVIDER, CARPETS AND RADIO

■ THE CALAIS IS TRIMMED IN VELOUR CLOTH AND IS OTHERWISE IDENTICAL TO THE DEVILLE.

ALL BUCKET SEAT BACKS FEATURE A RECESSED PANEL TO ALLOW INCREASED LEG ROOM IN THE REAR COMPARTMENT.

INSTRUMENT PANELS ARE REVISED WITH THE USE OF ISO STANDARD SYMBOLS, NEW POINTERS & CLEARER SPEEDO DIVISIONS. YELLOW POINTERS ON ALL MODELS EXCEPT STATESMAN AND CAPRICE WHICH HAVE WHITE.

GTS, SANDMAN AND STATESMAN HAVE A RESETTABLE TRIP ODOMETER.

GTS AND SANDMAN HAVE A BRUSHED BLACK CHROME INSTRUMENT SURROUND AND A NEW HORN BUTTON.

AN 'RTS RADIAL TUNED SUSPENSION' BADGE IS FITTED TO THE INSTRUMENT PANELS ON ALL VEHICLES EXCEPT WHEN OPTIONAL BIAS PLY TYRES ARE FITTED TO COMMERCIAL MODELS.

DOOR LOCK STRIKERS ON STATESMAN ARE CHROME PLATED TO IMPROVE APPEARANCE.

■ SEE PAGE A-1

HOLDEN 'HZ' FEATURES

STYLING - INTERIOR

SANDMAN, KINGSWOOD & HOLDEN COMMERCIALS

A BENCH FRONT SEAT WITH CENTRE FOLDING ARMREST IS STANDARD ON HOLDEN & KINGSWOOD COMMERCIALS, BUCKET SEATS WITH INFINITELY RECLINING MECHANISM AND SEAT SEPARATOR ARE OPTIONAL. BUCKET SEATS AND FLOORSHIFT CONSOLE ARE STANDARD ON SANDMAN.

VINYL & CHEVRON CLOTH TRIM IS OPTIONAL ON BOTH SEAT STYLES. BUCKET SEATS AND BENCH OUTBOARD POSITIONS HAVE INTEGRAL HEAD RESTRAINTS.

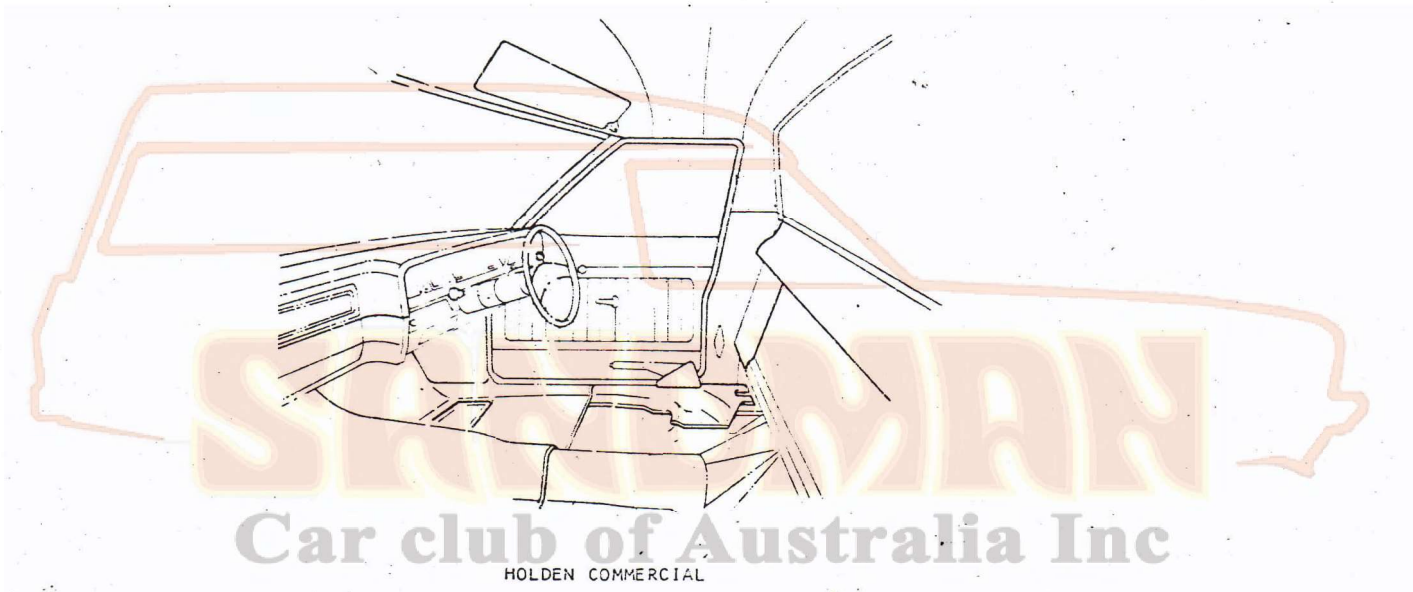

SEAT PADDING AND TRIM

SEAT CUSHION AND SEAT BACK COVERS ARE EMBOSSED PVC IN A VERTICAL FLUTED DESIGN. FRONT SEAT CUSHION AND BACK PADS ARE OF MOULDED FOAM CONSTRUCTION.

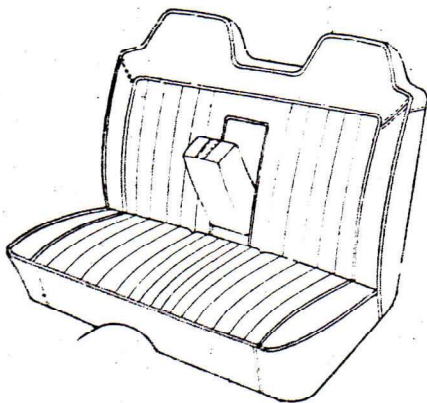

BENCH SEAT STANDARD HOLDEN & KINGSWOOD

DOOR TRIM

DOOR TRIM COVERED UP TO BELT LINE IS EMBOSSED PVC MATERIAL IN A BROAD VERTICAL RIB DESIGN.

Issued: JUNE, 1977

Revised:

HOLDEN 'HZ' FEATURES

STYLING - INTERIOR

SANDMAN, KINGSWOOD & HOLDEN COMMERCIALS

ARM RESTS

SANDMAN & KINGSWOOD

SHORT PADDED ARMRESTS WITH ASSOCIATED
DOOR HANDLES ARE FITTED TO THE FRONT
DOORS.

ASH TRAY

A DRAWER TYPE ILLUMINATED ASH TRAY IS LOCATED
IN THE CENTRE OF THE INSTRUMENT PANEL.

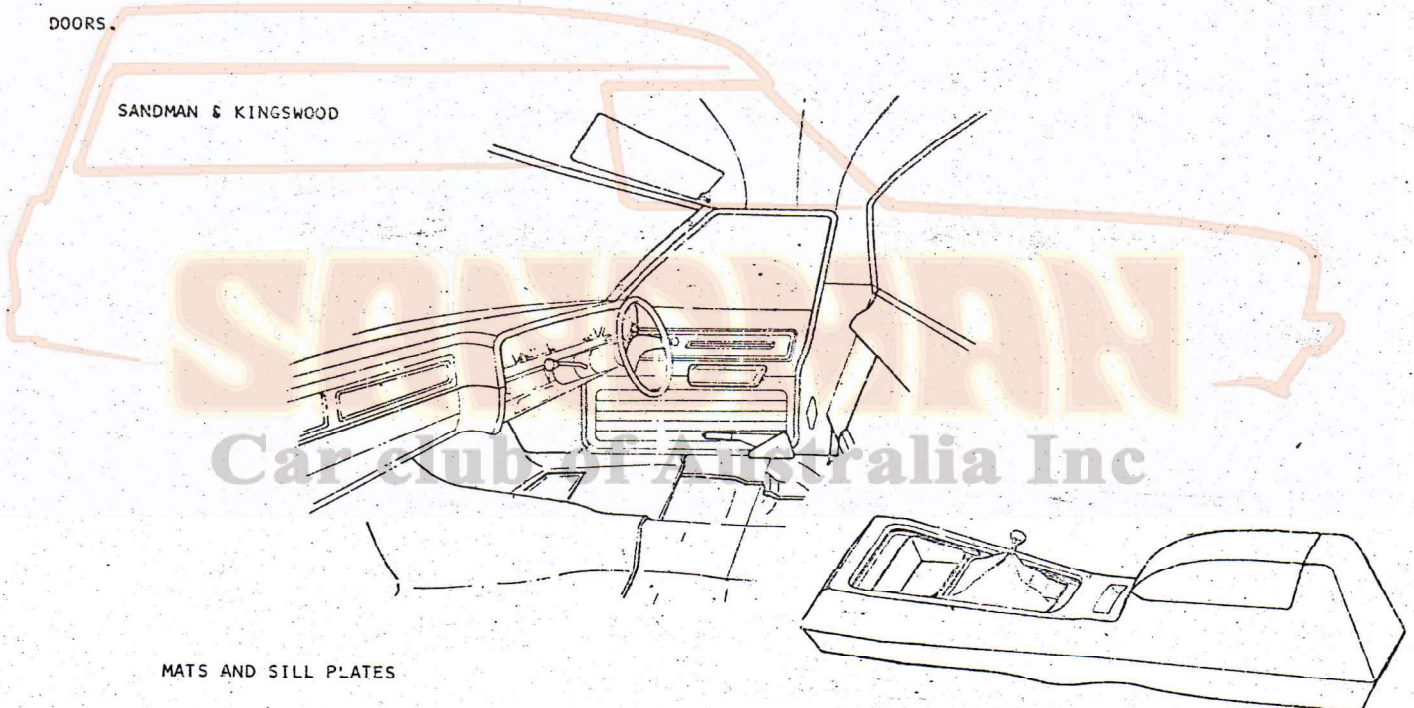

MATS AND SILL PLATES

HOLDEN MATS ON PASSENGER AND LUGGAGE COMPARTMENTS
ARE BLACK RUBBER SILL PLATES ARE CADMIUM PLATES
STEEL.

SANDMAN & KINGSWOOD - FLOOR COVERINGS ARE COLOUR
MATCHED HIGH LOOP-PILE CARPET.

SILL PLATES ARE CHROME PLATED STEEL.

SEAT SEPARATOR OR CONSOLE

SANDMAN CONSOLE STANDARD EQUIPMENT.
KINGSWOOD AND HOLDEN WITH BUCKET SEATS
A SEAT SEPARATOR OR CONSOLE IS FITTED.

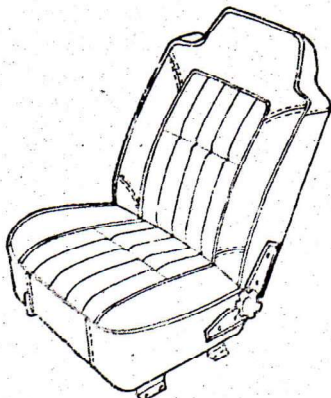

BUCKET SEAT STANDARD
SANDMAN AND OPTIONAL
HOLDEN & KINGSWOOD.

HEADLINING

SANDMAN AND KINGSWOOD PANEL VANS HAVE A
FULL LENGTH HEADLINING. HOLDEN HEADLINING
FINISHES AT THE START OF THE LOAD AREA,

Issued: JUNE, 1977

Revised:

HOLDEN 'HZ' FEATURES

STYLING - INTERIOR

'KINGSWOOD (A9K)' SEDAN, STATION WAGON

A BENCH FRONT SEAT WITH CENTRE FOLDING ARMREST IS STANDARD ON KINGSWOOD (A9K) PASSENGER MODELS. A FURTHER OPTION OF A REAR SEAT CENTRE FOLDING ARMREST IS AVAILABLE TOGETHER WITH THE FRONT BENCH SEAT AND WITH THIS COMBINATION THE PREMIER SEAT DESIGN IS USED. BUCKET SEATS ARE NOT AVAILABLE ON THIS MODEL. VINYL AND CHEVRON CLOTH TRIM IS OPTIONAL. BENCH OUTBOARD POSITIONS HAVE INTEGRAL HEAD RESTRAINTS.

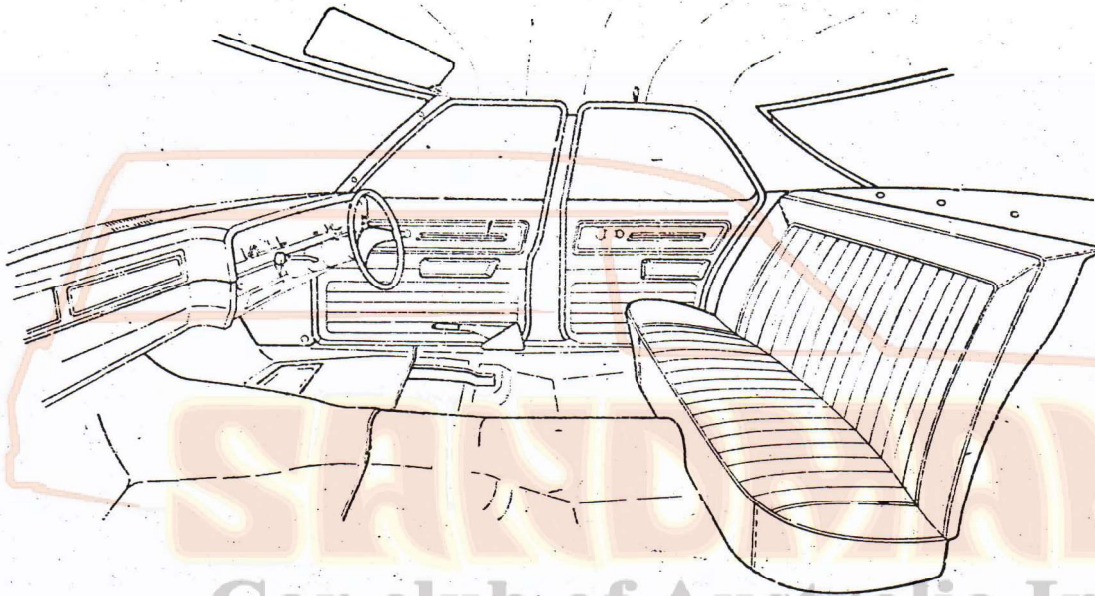

SEAT PADDING AND TRIM

SEAT COVERS ARE IN CARIBOU GRAIN SADLON VINYL MATERIAL WITH CUSHION AND SEAT BACK INSERTS OF CONTRASTING GRAIN MATERIAL. COVERS ARE DIELECTRICALLY EMBOSSED PVC IN A VERTICAL FLUTED DESIGN. FRONT SEAT CUSHION AND SEAT BACK PADS ARE OF MOULDED FOAM CONSTRUCTION.

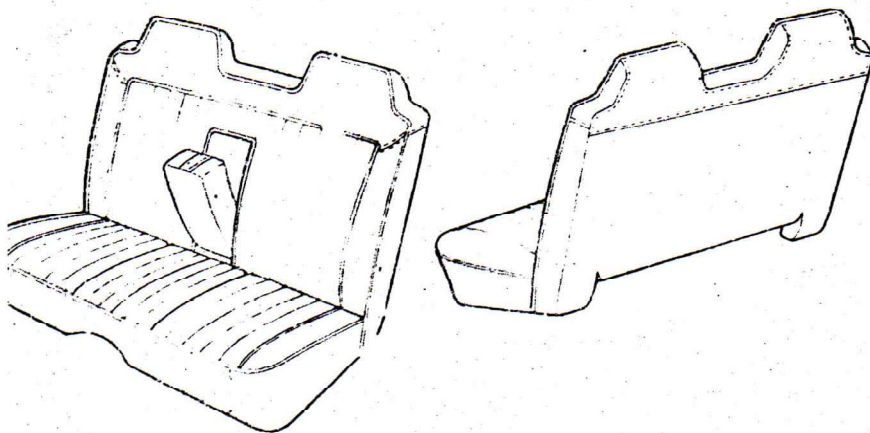

DOOR TRIM

DOOR TRIM COVERED UP TO BELT LINE IS EMBOSSED PVC MATERIAL IN A BROAD HORIZONTAL RIB DESIGN. A BRIGHT MouldING IS APPLIED TO THE UPPER DOOR AREA.

Issued: JUNE, 1977

Revised:

HOLDEN 'HIZ' FEATURES

STYLING - INTERIOR

KINGSWOOD (A9K) SEDAN AND STATION WAGON

STATION WAGON REAR SEAT

THE REAR SEAT BACK HAS A HINGED PRESSED METAL PAN WHICH FOLDS DOWN TO FORM AN EXTENSION TO THE TONNEAU FLOOR WITH A HINGED FLAP COVERING THE SPACE OVER THE SEAT CUSHION. BRIGHT FINISHED WEAR STRIPS ARE FITTED ON THE TONNEAU FLOOR.

ASH TRAYS

FOR FRONT SEAT PASSENGERS A ILLUMINATED DRAWER TYPE ASH TRAY IS FITTED IN THE CENTRE OF THE INSTRUMENT PANEL. FOR REAR SEAT PASSENGERS THE ASH TRAY IS LOCATED IN THE REAR OF THE SEAT BACK.

ASSIST HANDLES AND COAT HOOKS

ASSIST HANDLES ARE FITTED ON STATION WAGONS ONLY AND ARE LOCATED ABOVE THE FRONT PASSENGER'S DOOR AND ABOVE THE REAR DOORS.

COAT HOOKS ON STATION WAGONS ARE INTEGRAL WITH ASSIST HANDLE. COAT HOOKS ON SEDANS ARE LOCATED ONE EACH SIDE ABOVE REAR DOORS.

CARPET MATS & SILL PLATES

LOOP-PILE CARPET IS COLOUR KEYED TO MATCH THE TRIM. SEDAN LUGGAGE COMPARTMENT FEATURES A RUBBER MAT. SILL PLATES ARE MACHINE POLISHED CHROME PLATED STEEL.

ARM RESTS

SHORT PADDED DOOR ARM RESTS WITH ASSOCIATED DOOR HANDLES ARE FITTED TO THE FRONT DOORS ON ALL MODELS. REAR DOOR ARM RESTS ARE FITTED ON SEDANS ONLY.

Issued: JUNE, 1977

Revised:

HOLDEN 'HZ' FEATURES

STYLING - INTERIOR

'KINGSWOOD SL' SEDAN, STATION WAGON

BUCKET SEATS WITH INFINITELY RECLINING MECHANISM AND SEAT SEPARATOR ARE STANDARD ON KINGSWOOD 'SL'. A BENCH FRONT SEAT WITH CENTRE FOLDING ARM REST IS OPTIONAL. A FURTHER OPTION OF A REAR SEAT CENTRE FOLDING ARM REST IS AVAILABLE TOGETHER WITH THE FRONT BENCH SEAT AND WITH THIS COMBINATION THE PREMIER SEAT DESIGN IS USED. VINYL AND CHEVRON CLOTH TRIM IS OPTIONAL ON ALL SEAT STYLES. BUCKET SEATS AND BENCH OUTBOARD POSITIONS HAVE INTEGRAL HEAD RESTRAINTS.

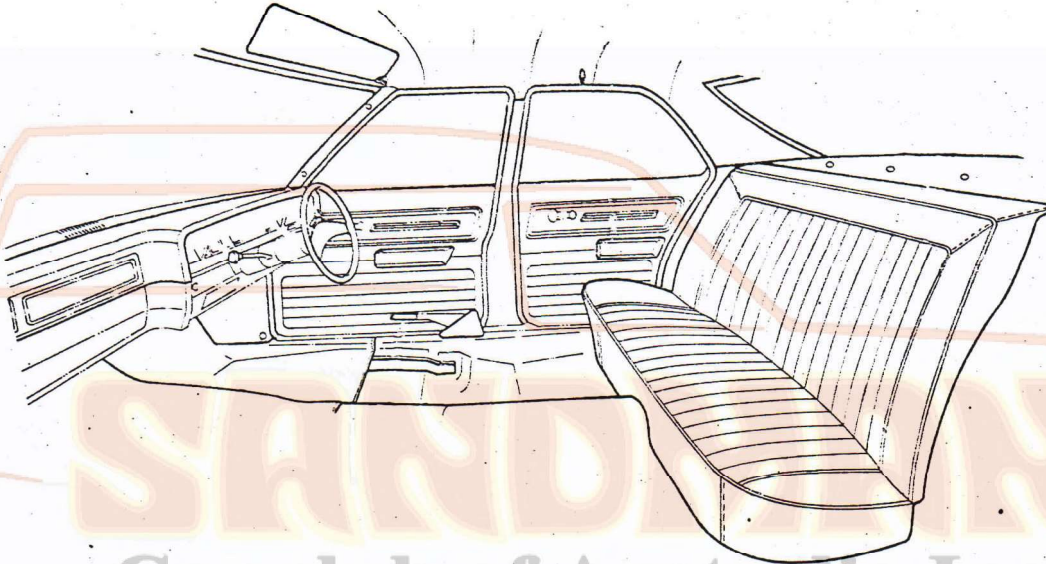

Car club of Australia Inc

SEAT PADDING AND TRIM

SEAT COVERS ARE IN CARIBOU GRAIN SADLON VINYL MATERIAL WITH CUSHION AND SEAT BACK INSERTS OF CONTRASTING GRAIN MATERIAL. COVERS ARE DIELECTRICALLY EMBOSSED PVC IN A VERTICAL FLUTED DESIGN. FRONT SEAT CUSHION AND SEAT BACK PADS ARE OF MOULDED FOAM CONSTRUCTION.

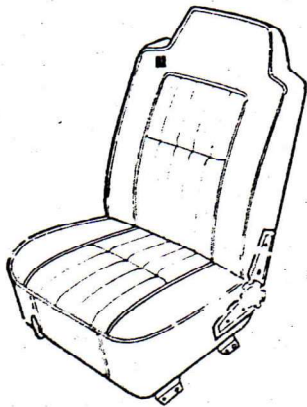

DOOR TRIM

DOOR TRIM COVERED UP TO BELT LINE IS EMBOSSED PVC MATERIAL IN A BROAD HORIZONTAL RIB DESIGN. A BRIGHT MOULDING IS APPLIED TO THE UPPER DOOR AREA.

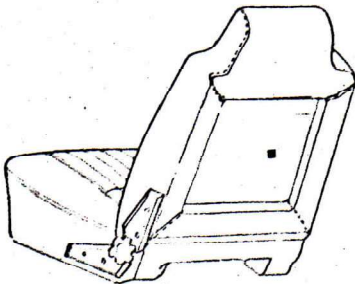

Issued: JUNE, 1977 • Revised: AUGUST, 1977

HOLDEN 'HZ' FEATURES

STYLING - INTERIOR

KINGSWOOD SL SEDAN & STATION WAGON

STATION WAGON REAR SEAT

THE REAR SEAT BACK HAS A HINGED PRESSED METAL PAN WHICH FOLDS DOWN TO FORM AN EXTENSION TO THE TONNEAU FLOOR WITH A HINGED FLAP COVERING THE SPACE OVER THE SEAT CUSHION. BRIGHT FINISHED WEAR STRIPS ARE FITTED ON THE TONNEAU FLOOR.

ASH TRAYS

FOR FRONT SEAT PASSENGERS AN ILLUMINATED DRAWER TYPE ASH TRAY IS FITTED IN THE CENTRE OF THE INSTRUMENT PANEL. FOR REAR SEAT PASSENGERS THE ASH TRAY IS LOCATED IN THE REAR OF THE SEAT SEPERATOR WITH BUCKET SEATS AND THE SEAT BACK WITH A BENCH SEAT.

ASSIST HANDLES AND COAT HOOKS

ASSIST HANDLES ARE FITTED ON STATION WAGONS ONLY AND ARE LOCATED ABOVE THE FRONT PASSENGER'S DOOR AND ABOVE THE REAR DOORS. COAT HOOKS ON STATION WAGONS ARE INTEGRAL WITH ASSIST HANDLE. COAT HOOKS ON SEDANS ARE LOCATED ONE EACH SIDE ABOVE REAR DOORS.

CARPET MATS & SILL PLATES

LOOP-PILE CARPET IS COLOUR KEYED TO MATCH THE TRIM. SEDAN LUGGAGE COMPARTMENT FEATURES A RUBBER MAT. SILL PLATES ARE MACHINE POLISHED CHROME PLATED STEEL.

ARM RESTS

SHORT PADDED DOOR ARM RESTS WITH ASSOCIATED DOOR HANDLES ARE FITTED TO THE FRONT DOORS ON ALL MODELS. REAR DOOR ARM RESTS ARE FITTED ON SEDANS ONLY.

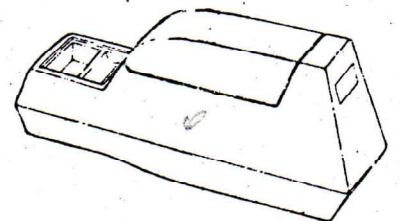

SEAT SEPARATOR

THE SEAT SEPARATOR FEATURES A STORAGE COMPARTMENT WITH A PADDED AND HINGED HIGH ARM-REST. THE FORWARD SECTION INCLUDES A SMALL ITEMS TRAY AND A COIN PECESS.

Issued: JUNE, 1977

Revised:

HOLDEN 'HIZ' FEATURES

STYLING - INTERIOR

PREMIER SEDAN AND STATION WAGON

FRONT BUCKET SEATS WITH INFINITELY VARIABLE RECLINING MECHANISM ARE STANDARD ON PREMIER MODELS WITH A BENCH SEAT WITH CENTRE FOLDING ARMREST BEING AVAILABLE AS AN OPTION. VINYL & CORNICHE TRIM IS OPTIONAL ON BOTH SEAT STYLES. BENCH OUTBOARD AND BUCKET SEATS HAVE INTEGRAL HEAD RESTRAINTS. THE REAR BENCH SEAT FEATURES A CENTRE FOLDING ARMREST.

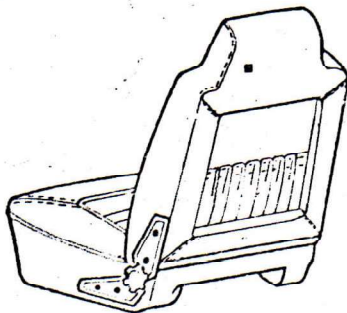
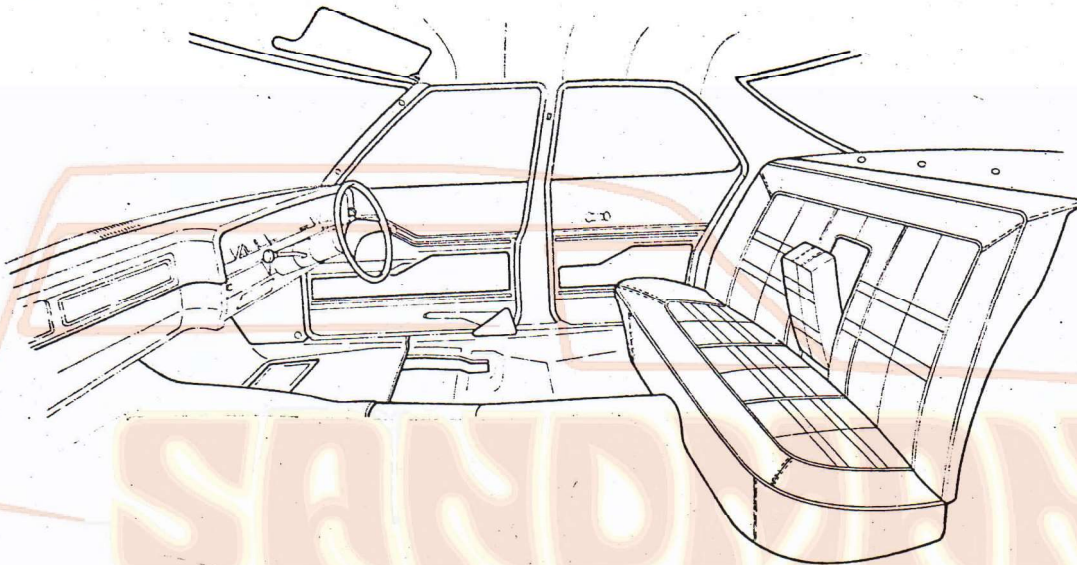

SEAT PADDING AND TRIM

SEAT COVERS ARE IN CARIBOU GRAIN SADLON VINYL MATERIAL. COVERS ARE SEWN WITH COVER PADS AND PULLDOWNS IN CUSHIONS AND SEAT BACKS. FRONT SEAT CUSHION AND SEAT BACK PADS ARE OF MOULDED FOAM CONSTRUCTION.

DOOR TRIM

DOOR TRIM IS COVERED UP TO BELT LINE WITH PVC MATERIAL WITH A BRIGHT HORIZONTAL MOULDING. A CARPET PANEL COVERS LOWER PORTION OF DOORS. CONSTRUCTION AND DESIGN IS THE SAME AS GTS SEDAN.

Issued: JUNE, 1977

Revised: AUGUST, 1977

HOLDEN 'H2' FEATURES

STYLING - INTERIOR

PREMIER SEDAN AND STATION WAGON

STATION WAGON REAR SEAT

THE REAR SEAT HAS A HINGED PRESSED METAL PAN WHICH FOLDS DOWN TO FORM AN EXTENSION TO THE TONNEAU FLOOR WITH A HINGED FLAP COVERING THE SPACE OVER THE SEAT CUSHION. BRIGHT FINISHED WEAR STRIPS ARE FITTED ON THE TONNEAU FLOOR.

ASH TRAYS

FOR FRONT SEAT PASSENGERS AN ILLUMINATED DRAWER TYPE ASH TRAY IS FITTED IN THE CENTRE OF THE INSTRUMENT PANEL. FOR REAR SEAT PASSENGERS THE ASH TRAYS ARE LOCATED IN EACH REAR DOOR ARM REST FOR SEDANS AND IN REAR SECTION OF SEAT SEPERATOR/ CONSOLE FOR STATION SEDANS.

ASSIST HANDLES AND COAT HOOKS

ASSIST HANDLES ARE FITTED ON STATION WAGONS ONLY AND ARE LOCATED ABOVE THE FRONT PASSENGER'S DOOR AND ABOVE THE REAR DOORS. COAT HOOKS ON STATION WAGONS ARE INTEGRAL WITH REAR ASSIST HANDLES. COAT HOOKS ON SEDANS ARE LOCATED ONE EACH SIDE ABOVE REAR DOORS.

MATS AND SILL PLATES

FLOOR COVERINGS ARE COLOUR MATCHED HIGH LOOP PILE CARPET. SEDAN LUGGAGE COMPARTMENT FEATURES A RUBBER MAT. SILL PLATES ARE CHROME PLATED STEEL.

ARM RESTS

ARM RESTS ARE LOCATED ON THE FRONT AND REAR DOORS, SEAT SEPARATOR/CONSOLE, REAR SEAT BACK. THE DOOR ARM RESTS ARE FULL LENGTH AND PADDED WITH ASSOCIATED DOOR HANDLES. STATION WAGONS DO NOT HAVE ARM RESTS ON THE REAR DOORS. THE CENTRE ARM REST ON THE SEAT SEPARATOR/CONSOLE IS A HINGED PADDED TYPE. THE ARM REST IN THE REAR SEAT BACK IS THE PADDED FOLD DOWN TYPE TRIMMED TO MATCH THE SEATS, AND A SIMILAR ARM REST IS FITTED IN THE OPTIONAL FRONT BENCH SEAT.

MAP POCKETS

MAP POCKETS ARE LOCATED ON EACH FRONT BUCKET SEAT BACK.

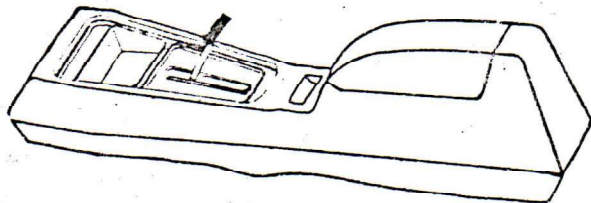
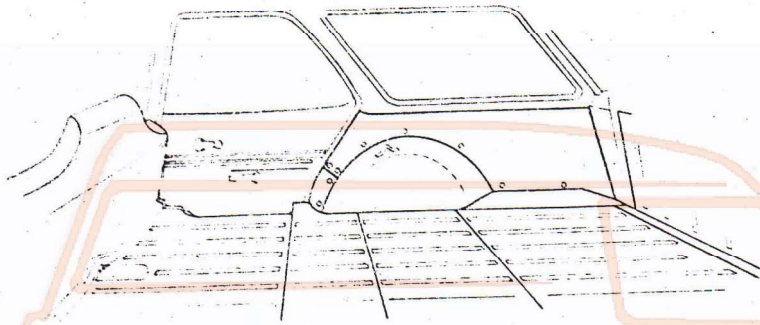

A CONSOLE IS STANDARD FITMENT ON THIS MODEL. THE FULL LENGTH CONSOLE EXTENDS REAPWARDS FROM UNDER THE INSTRUMENT PANEL AND FEATURES A STORAGE COMPARTMENT WITH A HINGED PADDED ARM-REST COVERED IN COLOUR MATCHED PVC. A STOWAGE RECESS IS LOCATED FORWARD OF THE GEARSHIFT WITH A COIN TRAY AT THE REAR EDGE OF THE GEARSHIFT COVER.

Issued: JUL, 1977

Revised:

HOLDEN 'HIZ' FEATURES

STYLING - INTERIOR

■ 'GTS' 4 DOOR SEDAN

THE MONARO 'GTS' 4-DOOR SEDAN HAS INFINITELY VARIABLE RECLINING FRONT BUCKET SEATS WITH INTEGRAL HEAD RESTRAINTS AS STANDARD EQUIPMENT. VINYL AND PLAID CLOTH TRIM IS AVAILABLE AS AN OPTION, AND WITH THIS TRIM A DIFFERENT INSERT PATTERN IS USED TOGETHER WITH A REAR SEAT FOLDING ARMREST.

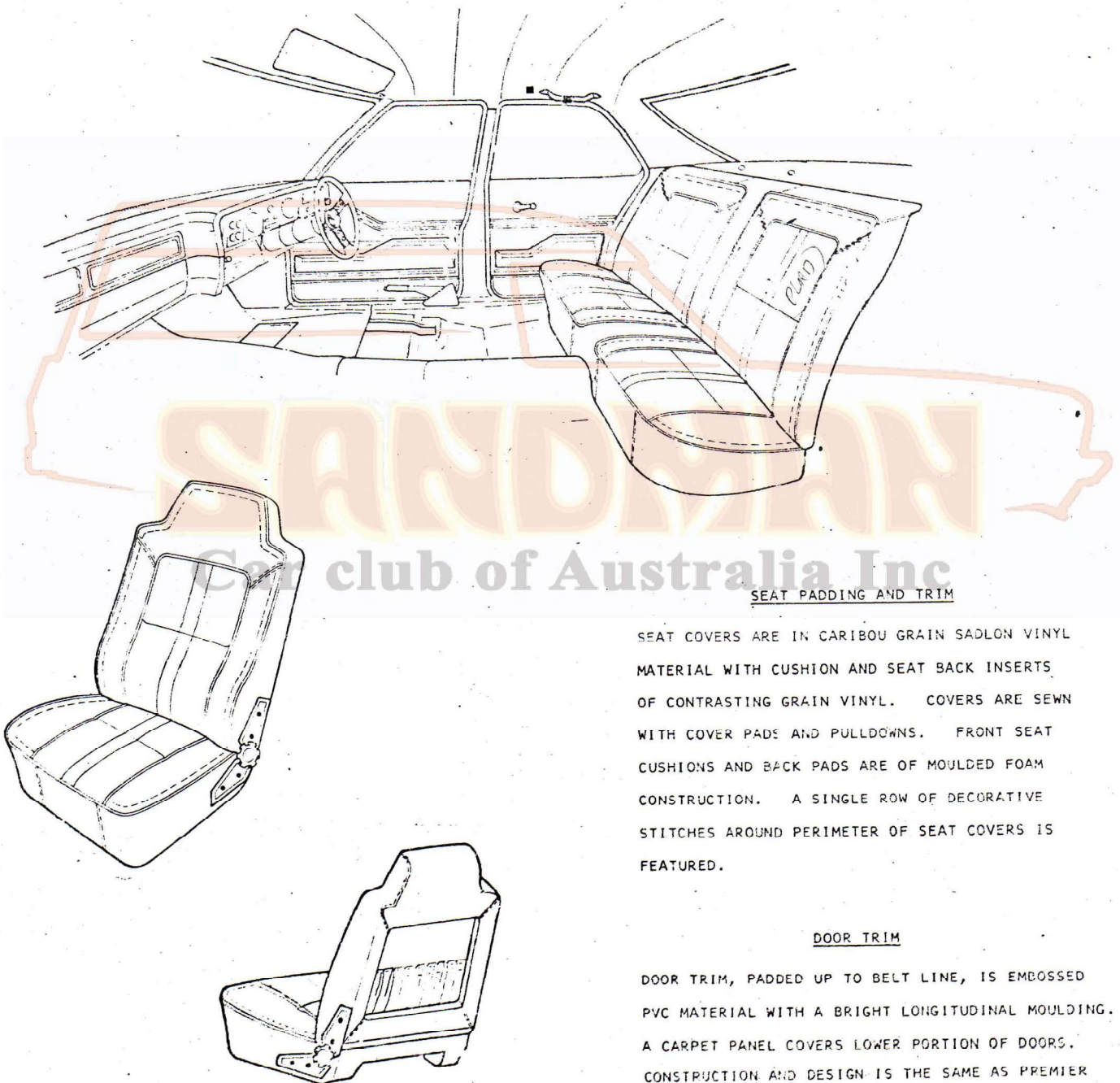

SEAT PADDING AND TRIM

SEAT COVERS ARE IN CARIBOU GRAIN SADLON VINYL MATERIAL WITH CUSHION AND SEAT BACK INSERTS OF CONTRASTING GRAIN VINYL. COVERS ARE SEWN WITH COVER PADS AND PULLDOWNS. FRONT SEAT CUSHIONS AND BACK PADS ARE OF MOULDED FOAM CONSTRUCTION. A SINGLE ROW OF DECORATIVE STITCHES AROUND PERIMETER OF SEAT COVERS IS FEATURED.

DOOR TRIM

DOOR TRIM, PADDED UP TO BELT LINE, IS EMBOSSED PVC MATERIAL WITH A BRIGHT LONGITUDINAL MOULDING. A CARPET PANEL COVERS LOWER PORTION OF DOORS. CONSTRUCTION AND DESIGN IS THE SAME AS PREMIER SEDAN.

Issued: *June*, 1977

■ Revised: *October*, 1977

HOLDEN 'HZ' FEATURES

STYLING - INTERIOR

■ 'GTS' 4 DOOR SEDAN

■ ASSIST HANDLES AND COAT HOOKS

ASSIST HANDLES ARE FITTED ABOVE THE FRONT PASSENGER'S DOOR AND ABOVE THE REAR DOORS. COAT HOOKS ARE INTEGRAL WITH REAR ASSIST HANDLES.

ASH TRAYS

FOR FRONT SEAT PASSENGERS AN ILLUMINATED TYPE ASH TRAY IS FITTED IN THE CENTRE OF THE INSTRUMENT PANEL. FOR REAR PASSENGERS THE ASH TRAY IS INTEGRAL WITH THE REAR OF THE CONSOLE.

MATS AND SILL PLATES

FLOOR COVERINGS ARE COLOUR MATCHED HIGH LOOP PILE CARPET. LUGGAGE COMPARTMENT FEATURES A RUBBER MAT. SILL PLATES ARE CHROME FINISHED STEEL.

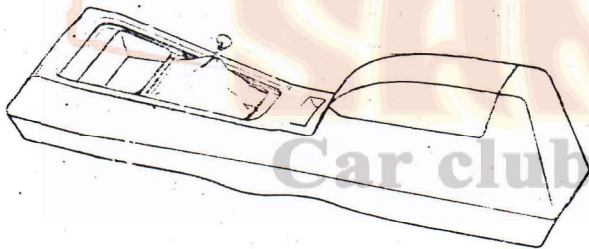

CONSOLE

A CONSOLE IS STANDARD FITMENT ON THIS MODEL. IT IS A FULL LENGTH CONSOLE EXTENDING REARWARDS FROM UNDER THE INSTRUMENT PANEL AND FEATURES A STORAGE COMPARTMENT WITH A HINGED PADDED ARM REST COVERED IN COLOUR MATCHED PVC. AND A STOWAGE RECESS FORWARD OF THE GEARSHIFT. A COIN TRAY IS LOCATED AT THE REAR EDGE OF THE GEARSHIFT COVER.

MAP POCKETS

MAP POCKETS ARE LOCATED ON EACH FRONT BUCKET SEAT BACK.

ARM RESTS

ARM RESTS ARE LOCATED ON THE FRONT AND REAR DOORS AND CONSOLE. THE DOOR ARM RESTS ARE FULL LENGTH SADLON COVERED AND PADDED WITH ASSOCIATED DOOR HANDLES. THE ARM REST ON THE CONSOLE IS A HINGED TYPE COVERED IN COLOUR MATCHED ELASCOFAB SADLON MATERIAL. WITH OPTIONAL PLAID CLOTH TRIM. THE ARM REST IN THE REAR SEAT BACK IS THE PADDED FOLD DOWN TYPE, TRIMMED TO MATCH THE SEATS.

Issued: JUNE, 1977

Revised: OCTOBER, 1977

HOLDEN '11Z' FEATURES

STYLING - INTERIOR

STATESMAN DEVILLE AND CALAIS

FRONT SEATS FOR THESE MODELS ARE BUCKET SEATS WITH AN INFINITELY VARIABLE RECLINING MECHANISM AND INTEGRAL HEAD RESTRAINTS. A CENTRE FOLDING ARM REST IS STANDARD IN THE REAR SEAT.

FRONT BENCH SEAT IS AVAILABLE AS AN OPTION ON BOTH MODELS AND VINYL AND CORNICHE CLOTH TRIM IS AVAILABLE ON DEVILLE.

LAIS: REFER A-1

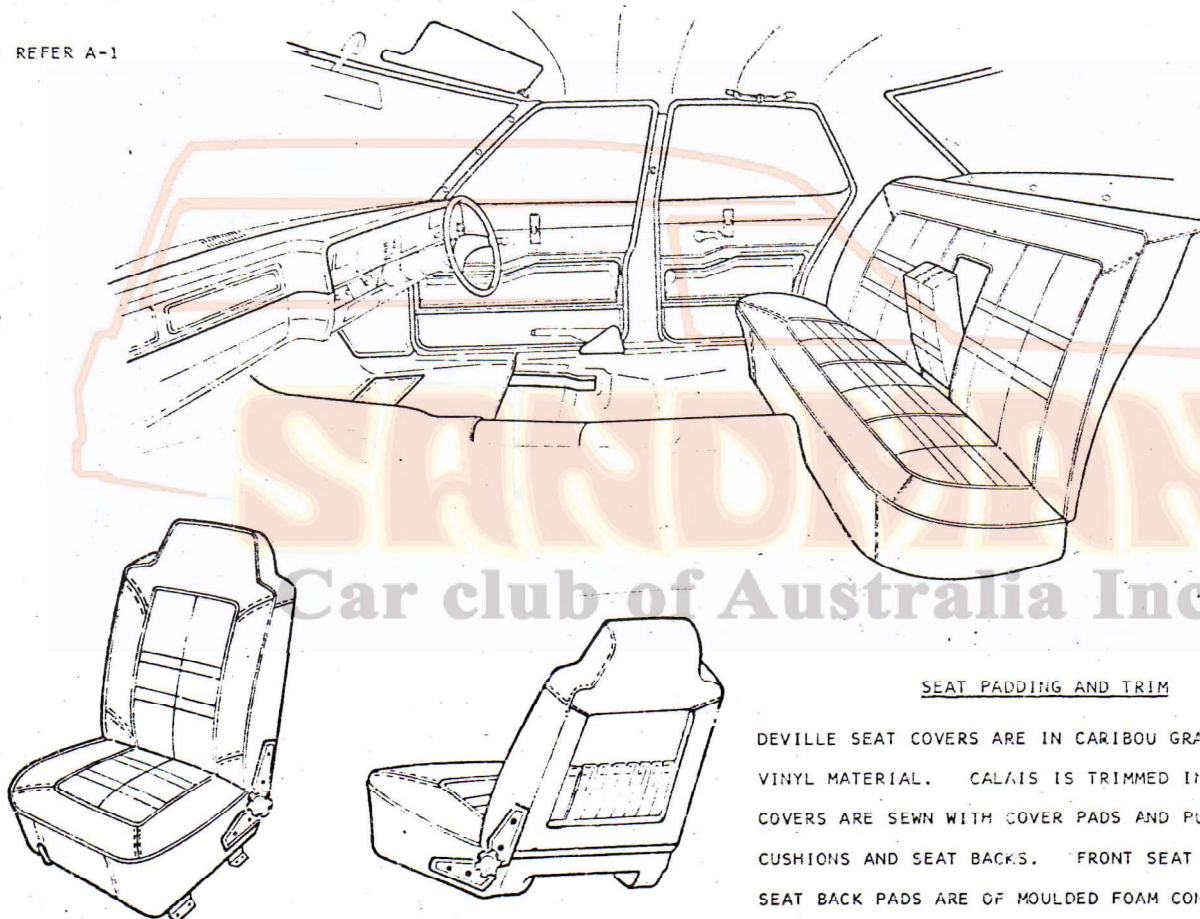

SEAT PADDING AND TRIM

DEVILLE SEAT COVERS ARE IN CARIBOU GRAIN SADLON VINYL MATERIAL. CALAIS IS TRIMMED IN VELOUR CLOTH. COVERS ARE SEWN WITH COVER PADS AND PULLDOWNS IN CUSHIONS AND SEAT BACKS. FRONT SEAT CUSHION AND SEAT BACK PADS ARE OF MOULDED FOAM CONSTRUCTION.

OPTIONAL FRONT BENCH SEAT

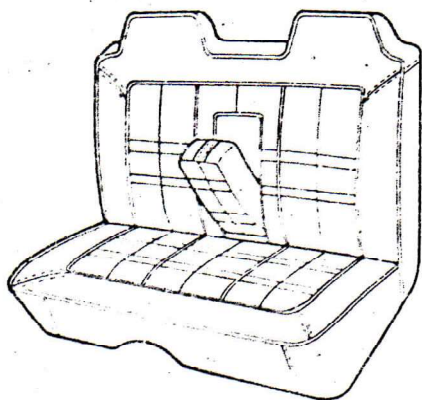

DOOR TRIM

DOOR TRIM IS COVERED UP TO BELT LINE IN PVC MATERIAL WITH A VERTICAL ROSEWOOD DECORATIVE PANEL BEARING A LAUREL WREATH EMBLEM AND SURROUNDED BY A BRIGHT MOULDING. A CARPET PANEL COVERS THE LOWER PORTION OF DOORS.

Issued: JUNE, 1977

Revised: OCTOBER, 1977

HOLDEN 'HIZ' FEATURES

STYLING - INTERIOR

■ STATESMAN DEVILLE AND CALAIS

ASSIST HANDLES AND COAT HOOKS

ASSIST HANDLES ARE FITTED ABOVE THE FRONT PASSENGER'S DOOR AND ABOVE THE REAR DOORS. COAT HOOKS ARE INTEGRAL WITH REAR ASSIST HANDLES.

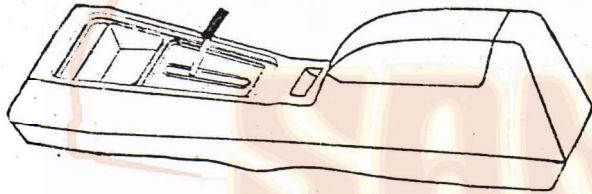

A CONSOLE IS STANDARD FITMENT ON THIS MODEL. THE FULL LENGTH CONSOLE EXTENDS REARWARDS FROM UNDER THE INSTRUMENT PANEL AND FEATURES A STORAGE COMPARTMENT WITH A HINGED PADDED ARM-REST COVERED IN COLOUR MATCHED PVC. A STOWAGE RECESS IS LOCATED FORWARD OF THE GEARSHIFT WITH A COIN TRAY AT THE REAR EDGE OF THE GEARSHIFT COVER.

ASH TRAYS

FOR FRONT SEAT PASSENGERS AN ILLUMINATED DRAWER TYPE ASH TRAY IS FITTED IN THE CENTRE OF THE INSTRUMENT PANEL. FOR REAR SEAT PASSENGERS THE ASH TRAYS ARE LOCATED IN EACH REAR DOOR ARM REST.

MATS AND SILL PLATES

FLOOR COVERINGS ARE COLOUR MATCHED CUT PILE CARPET. SILL PLATES ARE CHROME PLATED STEEL. LUGGAGE COMPARTMENT FEATURES A MOULDED CARPET AND SPARE WHEEL COVER.

Car Club of Australia Inc

VANITY MIRROR

A VANITY MIRROR IS FITTED INSIDE THE INSTRUMENT PANEL COMPARTMENT.

MAP POCKETS

MAP POCKETS ARE LOCATED ON EACH FRONT BUCKET SEAT BACK.

ARM RESTS

ARM RESTS ARE LOCATED ON THE FRONT AND REAR DOORS, SEAT SEPARATOR AND REAR SEAT BACK. THE DOOR ARM RESTS ARE FULL LENGTH AND PADDED WITH ASSOCIATED DOOR HANDLES. THE ARM REST ON THE SEAT SEPARATOR IS A HINGED PADDED TYPE COVERED IN COLOUR MATCHED PVC. THE ARM REST IN THE REAR SEAT BACK IS THE PADDED FOLD DOWN TYPE TRIMMED TO MATCH THE SEATS.

■ CALAIS - REFER A-1

Issued: OCTOBER, 1977

■ Revised: OCTOBER, 1977

HOLDEN 'HZ' FEATURES

STYLING - INTERIOR

STATESMAN CAPRICE

FRONT BUCKET SEATS WITH INTEGRAL HEAD RESTRAINTS AND INFINITELY VARIABLE RECLINING MECHANISM IS THE ONLY SEATING ARRANGEMENT AVAILABLE IN THIS MODEL. VINYL AND VELOUR CLOTH TRIM IS OPTIONAL.

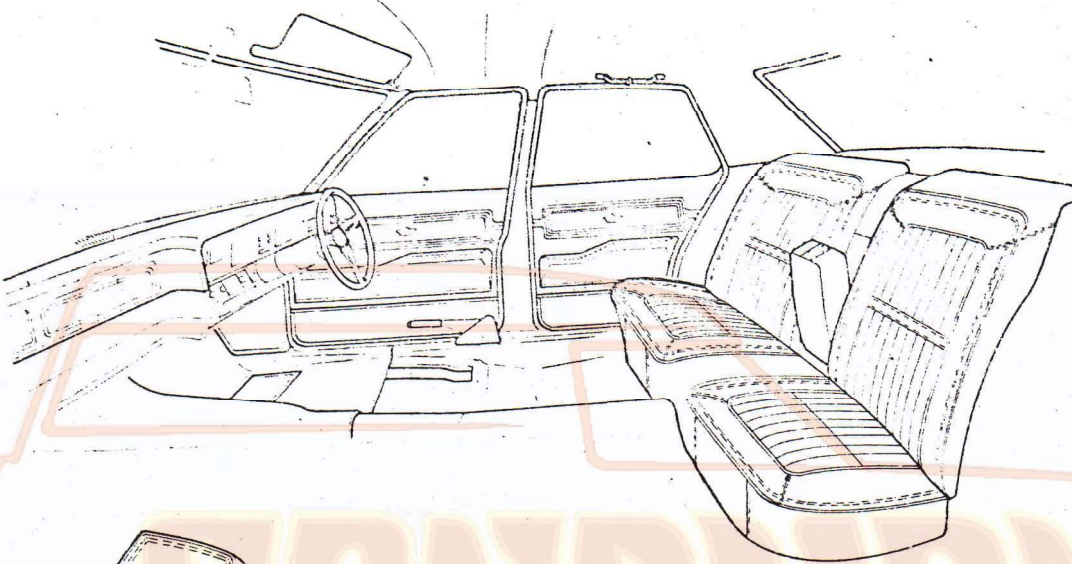

SEAT PADDING AND TRIM

SEAT COVERS ARE SEWN LEATHER IN A VERTICAL FLUTED DESIGN. CUSHIONS AND SEAT BACKS HAVE COVER PADS AND PULLDOWNS. FRONT SEAT CUSHIONS AND SEAT BACKS ARE OF MOULDED FOAM CONSTRUCTION.

A DOUBLE ROW OF DECORATIVE STITCHES AROUND THE PERIMETER OF COVERS IS FEATURED.

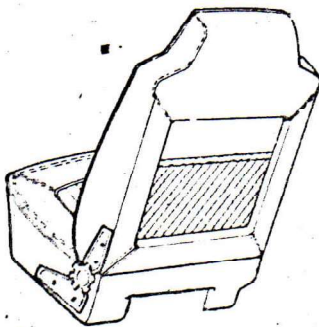
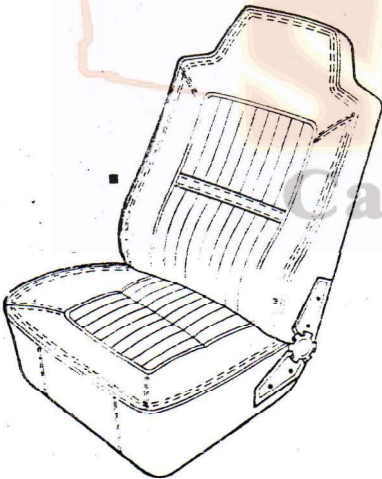

DOOR TRIM

DOOR AND GARNISH RAIL TRIM IS SADLON ELASCOFAB MATERIAL WITH AN INSERT PANEL BEARING A CAPRICE EMBLEM AND SURROUNDED BY A BURL WALNUT PANEL AND A BRIGHT MOULDING.

LOWER PORTION OF DOORS HAVE A CARPET PANEL. IN FRONT DOORS MAP POCKETS ARE INCORPORATED IN FORWARD SECTION OF CARPET PANELS.

Issued: JUNE, 1977

Revised: AUGUST, 1977

HOLDEN 'HZ' FEATURES

STYLING - INTERIOR

STATESMAN CAPRICE

ASSIST HANDLES AND COAT HOOKS

ASSIST HANDLES ARE FITTED ABOVE THE FRONT PASSENGER'S DOOR AND ABOVE THE REAR DOORS. COAT HOOKS ARE INTEGRAL WITH REAR ASSIST HANDLES.

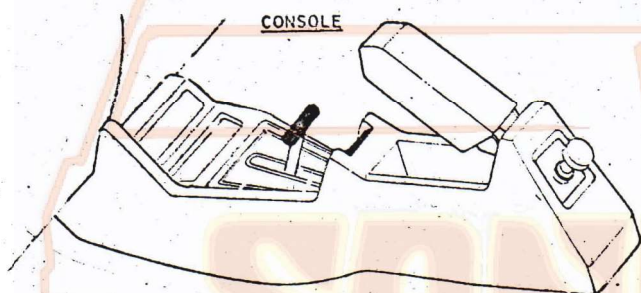

A PADDED AND TRIMMED CONSOLE HOUSING THE AUTOMATIC TRANSMISSION 'T' BAR IS STANDARD FITMENT ON THIS TOP OF THE LINE MODEL. IT EXTENDS REARWARDS FROM UNDER THE INSTRUMENT PANEL AND FEATURES A STORAGE COMPARTMENT, SWITCHES FOR ELECTRIC WINDOWS, PROVISION FOR STEREO TAPE DECK, CIGAR LIGHTER FOR REAR PASSENGERS AND A HINGED HIGH PADDED ARM REST COVERED IN COLOUR MATCHED ELASCOFAB MATERIAL.

ASH TRAYS

FOR FRONT SEAT PASSENGERS AN ILLUMINATED DRAWER TYPE ASHTRAY IS FITTED IN THE CENTRE OF THE INSTRUMENT PANEL. FOR REAR SEAT PASSENGERS THE ASH TRAYS ARE LOCATED IN EACH REAR DOOR ARM RESTS.

MATS AND SILL PLATES

FLOOR COVERINGS ARE COLOUR MATCHED CUT PILE CARPET. SILL PLATES ARE CHROME PLATED STEEL. LUGGAGE COMPARTMENT FEATURES A MOULDED CARPET AND A SPARE WHEEL COVER.

VANITY MIRROR

A VANITY MIRROR IS FITTED INSIDE THE INSTRUMENT PANEL COMPARTMENT.

MAP POCKETS

NYLON FISHNET MAP POCKETS ARE LOCATED ON EACH FRONT BUCKET SEAT BACK. WITH OPTIONAL CLOTH TRIM A MATCHING CLOTH SLEEVE IS FITTED INSIDE THE FISHNET.

ARM RESTS

ARM RESTS ARE LOCATED ON THE FRONT AND REAR DOORS, CONSOLE AND REAR SEAT BACK.

THE DOOR ARM RESTS ARE FULL LENGTH SADLON COVERED AND PADDED WITH ASSOCIATED DOOR HANDLES.

THE ARM REST ON THE CONSOLE IS A HINGED TYPE COVERED IN COLOUR MATCHED ELASCOFAB SADLON MATERIAL.

THE ARM REST IN THE REAR SEAT BACK IS THE PADDED FOLD DOWN TYPE, TRIMMED TO MATCH THE SEATS.

Issued: JUNE, 1977

Revised:

HOLDEN 'HZ' FEATURES

STYLING - INTERIOR

STEERING COLUMN MULTI-FUNCTION CONTROL

The Steering Column mounted multi-function switch continues to be used on 'HZ'. The most frequently operated controls are grouped together in one unit within finger-tip reach of the driver's right hand. The control is mounted on the steering column below the ignition lock and the functional switch reaches to just below the steering wheel rim.

The Control Operates : Windscreen wipers, washers and a single sweep wipe, headlamp dip, headlight flash, and finally lane change and turn signals. New for 'HZ' is a demand type windscreen washer pump system.

This list describes the operation of the functions shown on the illustration :-

1. LEFT TURN INDICATOR (Move lever anti-clockwise.)
2. RIGHT TURN INDICATOR (Move lever clockwise.)
3. LANE CHANGE (Light movement towards desired direction)
4. HEADLAMP DIP (Lift control towards steering wheel rim against stop)
5. HEADLAMP FLASH (Light pull towards dip position to detent Headlamps On or Off, i.e. Day or Night).
6. WINDSCREEN WIPER LOW SPEED (Rotate clockwise one click by gripping barrel section.)
7. WINDSCREEN WIPER HIGH SPEED (Rotate clockwise past low till second click.)
8. SINGLE SWEEP WIPE (Rotate anti-clockwise and release. Wipers will sweep once. Control is spring loaded to off position.)
9. WINDSCREEN WASHER (Push button on end of stalk for constant demand wash stream)

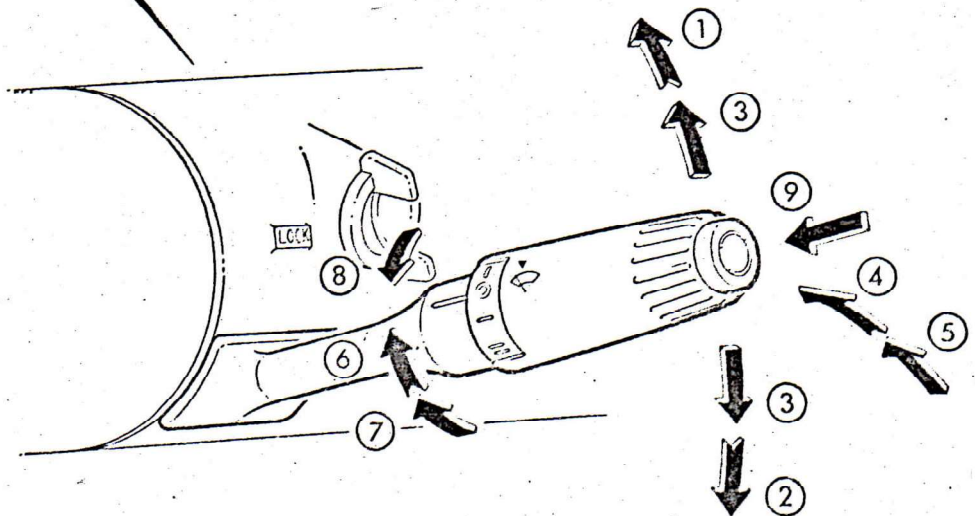

Issued: JUNE, 1977

Revised: AUGUST, 1977

HOLDEN '82' FEATURES

STYLING - INTERIOR

HOLDEN COMMERCIALS	KINGSWOOD SL KINGSWOOD	PREMIER	MONARO GTS SANDMAN	STATESMAN DEVILLE, CALAIS	STATESMAN CAPRICE
-----------------------	---------------------------	---------	-----------------------	------------------------------	----------------------

APPLICABILITY OF STANDARD WARNING LAMPS (ILLUMINATION COLOUR SHOWN IN BRACKETS) & GAUGES

INSTRUMENT FACIA FINISH		BLACK GRAIN TEXTURE	SATIN SILVER	ROSEWOOD	BLACK BRUSHED CHROME	ROSEWOOD	BURL WALNUT	
W A R N I N G	OIL	YES (RED)			NO	YES (RED)	NO	
	TEMPERATURE	YES (RED)	NO					
	GENERATOR	YES (RED)						
	BRAKE PARK	YES (RED)						
	BRAKE FAILURE	YES (RED)						
	DIRECTION INDICATOR	YES (GREEN ARROW)						
	HI BEAM	YES (BLUE LAMP SYMBOL)						
	OPT. ECONOMY	AVAILABLE (ORANGE)			NOT AVAILABLE			
G A U G E S	SPEEDOMETER	200 KM/H			220 KM/H	200KM/H WITH TRIPMETER		
	FUEL	YES						
	OIL	NO			YES	NO	YES	
	TEMPERATURE	NO	YES					
	VCLTS	NO			YES	NO	YES	
	TACHOMETER	NO			YES	NO		
	CLOCK	NO			YES	YES (DIGITAL)		

SEE PAGE A-1

APPLICABILITY OF STANDARD CONTROLS AND EQUIPMENT

STEERING WHEEL	OVAL		ROUND SPORTS	OVAL	ROUND
HORN	SINGLE		DUAL		
LIGHT SWITCH	YES				
WIPE/WASH/TURN/DIP/FLASH CONT.	YES				
DELAY WIPER	NO		YES		
INTERNAL HOOD RELEASE	YES				
CHOKE	MANUAL		AUTO		
UPPER LEVEL VENTS	YES				
HEATER DEMISTER	YES				
BLOWN UPPER LEVEL VENTILATION	NO	YES			NO
AIR-CONDITIONING	NO				YES
CIGAR LIGHTER	NO	YES			
RADIO	NO	KINGSWOOD NO SL YES	YES		
LOCK DOWN ANTENNA	NO	KINGSWOOD NO SL YES	YES	NO	
POWER ANTENNA	NO		YES		
ELECTRIC HEATED REAR WINDOW	KINGSWOOD NO SL YES		YES		
POWER SIDE WINDOWS				DEVILLE NO CALAIS YES	YES
POWER END GATE	NO	ST. SEDAN YES	-	-	-
REMOTE DECK LID RELEASE	NO				YES

Issued: JUNE, 1977

Revised: OCTOBER, 1977

HOLDEN 'HIZ' FEATURES

BODY

INDEX TO SECTION D

INTRODUCTION	D - 1
FORWARD VISION, HEADER PANEL, CARGO BARRIER, ROOF RAILS	D - 2
CENTRE PILLAR, DOOR FRAME, SUN VISORS, INSTRUMENT PANEL PAD	D - 3
DOOR LOCKS, CORROSION PROTECTION	D - 4
BUMPER BARS, SPARE WHEEL MOUNTING WINDSHIELD WIPER AND WASHERS	D - 5
FLOW-THROUGH VENTILATION	D - 6
FORCED AIR VENTILATION	D - 7
PRESSURE RELIEF AND BODY AIR CIRCULATION ROUTES	D - 8
'AIRMIX' HEATING SYSTEM	D - 9
INTEGRATED AIR-CONDITIONING SYSTEM	D - 10 & D - 11
FRONT SEAT BELTS	D - 12
REAR SEAT BELTS	D - 13
REAR VISION MIRRORS	D - 14

Issued: APRIL, 1977

Revised:

INDEX

BODY

INTRODUCTION BODY

WB FIFTH

THE "WB" IS THE ~~FOURTH~~ MODEL IN THE PROVEN "W" CAR BODY LINE FIRST INTRODUCED ON "HQ" AND DEVELOPED SUBSEQUENTLY ON "HJ" AND "HX".

THIS SERIES HAS BEEN CHANGED EXTENSIVELY IN THE BODY FOR WB WITH THE RANGE OF SIX BODY STYLES REMAINS UNCHANGED FOR 'HZ'

111" WHEELBASE SEDANS BEING DISCONTINUED.

'HZ' BODY RANGE

111" WHEELBASE SEDAN	3 VARIATIONS	- KINGSWOOD 'SL', PREMIER & MONARO GTS.
114" WHEELBASE SEDAN	2 VARIATIONS	- STATESMAN DEVILLE & STATESMAN CAPRICE
114" WHEELBASE STATION WAGON	2 VARIATIONS	- KINGSWOOD 'SL' & PREMIER
114" WHEELBASE HIGH ROOF PANEL VAN	2 VARIATIONS	- HOLDEN & KINGSWOOD
114" WHEELBASE COUPE UTILITY	2 VARIATIONS	- HOLDEN & KINGSWOOD
120.4" WHEELBASE - SEPARATE CAB FOR CAB & CHASSIS	1 VARIATION	- HOLDEN

PACKAGE OPTION BODY RANGE

THE FOLLOWING VEHICLES ARE OPTIONS BUT BECAUSE THEY ARE AVAILABLE FOR THE VEHICLE MODEL LIFE THEY ARE ACCEPTED AS AND SOMETIMES PRESENTED AS INDIVIDUAL MODELS.

111" WHEELBASE SEDAN	2 VARIATIONS	- KINGSWOOD & TAXI
■ 114" WHEELBASE SEDAN	1 VARIATION	- STATESMAN CALAIS
114" WHEELBASE HIGH ROOF PANEL VAN	3 VARIATIONS	- SANDMAN, SANDMAN 10 cwt. & 500 kg. AMBULANCE
114" WHEELBASE COUPE UTILITY	2 VARIATIONS	- SANDMAN, SANDMAN 10 cwt. & 500 kg.
120.4" WHEELBASE - CAB & CHASSIS	1 VARIATION	- AMBULANCE

■ SEE PAGE A-1

ISSUED: April, 1977 ■ REVISED: OCTOBER, 1977

HOLDEN 'H2' FEATURES

BODY

A FRONT VISION

LARGE AREA WINDSHIELD WITH THIN SECTION FRONT PILLARS AND ABSENCE OF QUARTER VENT OBSTRUCTIONS CONTRIBUTE TO EXCELLENT FORWARD AND SIDE VISION.

WINDSHIELD

ALL MODELS EXCEPT STATESMAN CAPRICE HAVE TOUGHENED SAFETY GLASS WITH MODIFIED ZONE.

WINDSHIELD FOR STATESMAN CAPRICE IS LAMINATED GLASS WITH TINTED UPPER SHADE BAND.

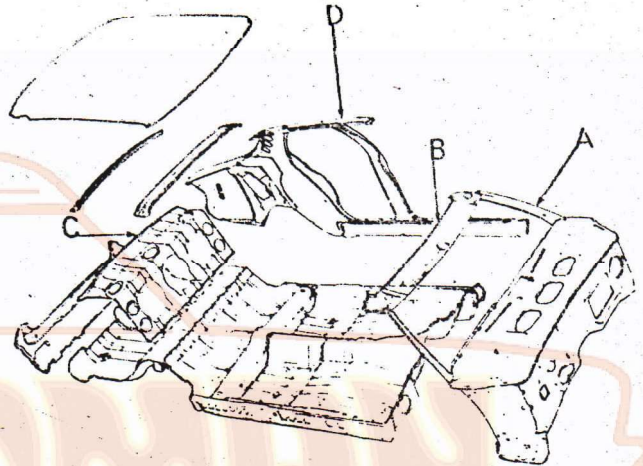

B SKID HEADER PANEL

AN IMPORTANT BODY STRUCTURAL MEMBER FOR CONTINUING OCCUPANT SAFETY IS THE USE OF A SKID HEADER PANEL. THIS CONSISTS OF A SMOOTH PANEL EXTENDING FROM THE TOP OF THE WINDSHIELD INTO THE FORWARD AREA OF THE ROOF. THE SKID HEADER PANEL, IF SEAT BELTS ARE CORRECTLY WORN, IS DESIGNED TO MINIMISE POSSIBLE HEAD INJURIES TO THE FRONT SEAT OCCUPANTS IN THE EVENT OF A COLLISION.

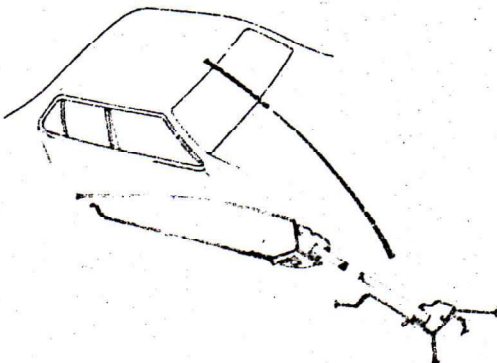

C STEEL CARGO BARRIER

THE PURPOSE OF THE STEEL CARGO BARRIER IS TO MINIMISE THE CHANCE OF ANY HEAVY OBJECTS INTRUDING INTO THE PASSENGER COMPARTMENT IN THE EVENT OF A COLLISION.

ALL STANDARD EQUIPMENT ITEMS IN THE LUGGAGE COMPARTMENT ARE FASTENED SECURELY.

D ROOF RAILS

ROOF RAILS HAVE ALL PINCH WELD FLANGES OUTBOARD. THIS FEATURE REDUCES THE CHANCES OF HEAD INJURY UPON IMPACT.

Issued: APRIL, 1977

Revised:

HOLDEN 'HZ' FEATURES

BODY

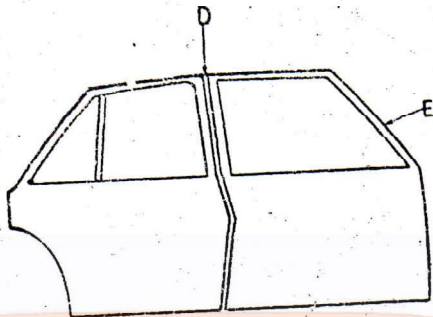

D CENTRE PILLAR

THIN SECTION CENTRE PILLARS PROVIDING A MINIMUM OF SIDE AND REAR VISION OBSTRUCTION ARE CONTINUED IN 'HZ'.

E DOOR FRAMES

DOOR FRAMES ARE THIN SECTION, COMPLEMENTING THIN FRONT PILLARS AND, TOGETHER WITH ABSENCE OF FRONT DOOR QUARTER VENT WINDOWS, CONTINUE TO PROVIDE EXCELLENT FORWARD AND SIDE VISION.

SUN VISORS

RIGHT AND LEFT SIDE ENERGY ABSORBING SUN VISORS ARE FITTED TO ALL MODELS. ALL CONTOURED SUN VISORS ARE OF FULL WIDTH CONSTRUCTION.

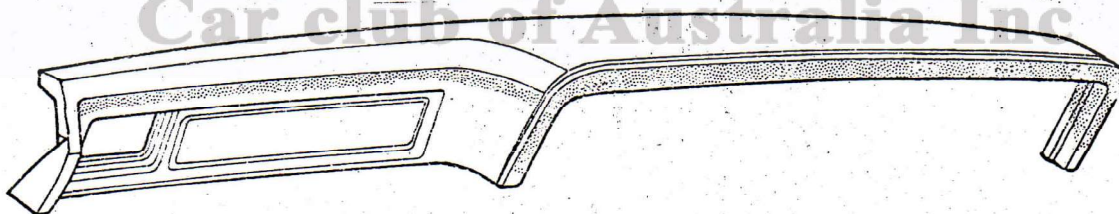

INSTRUMENT PANEL PAD

THE FULL WIDTH ENERGY ABSORBING INSTRUMENT PANEL PAD COMPLEMENTS THE NEW INSTRUMENTS AND CONTROLS.

THE CONSTRUCTION OF THE PAD IS POLURETHANE FOAM BONDED TO A RIGID PLASTIC BACKING AND COVERED WITH A FLEXIBLE PVC SKIN, COLOUR MATCHED TO INTERIOR TRIM.

THE PAD IS DESIGNED SO THAT UPON IMPACT ENERGY IS ABSORBED BY THE PROGRESSIVE COLLAPSE OF THE PAD. THE DASH PANEL AND INSTRUMENT CARRIER ARE ALSO OF ENERGY ABSORBING CONSTRUCTION.

Issued: APRIL, 1977

Revised:

HOLDEN 'HZ' FEATURES

BODY

DOOR LOCKS AND DOOR HANDLES

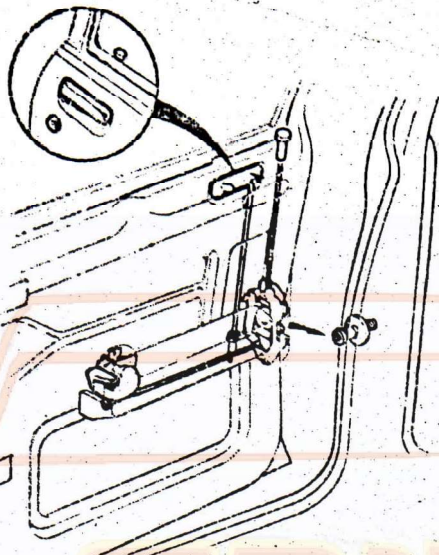

FORK TYPE DOOR LOCKS AND FLUSH FITTING EXTERIOR DOOR HANDLES ARE SAFETY FEATURES RETAINED IN ALL 'HZ' MODELS. DOOR LOCKS AND HANDLES OFFER ADDITIONAL OCCUPANT PROTECTION IN THE EVENT OF VEHICLE ROLL OVER. THE CHANCE OF ACCIDENTAL DOOR OPENING IS REDUCED DUE TO THE PROTECTION GIVEN BY THE FLUSH FITTING EXTERIOR DOOR HANDLES.

ANOTHER SAFETY ITEM IS THE FREE-WHEELING FEATURE OF THE DOOR LOCKS. WHEN THE INSIDE DOOR LOCKING KNOB IS DEPRESSED INTERNAL AND EXTERNAL DOOR HANDLES FREE-WHEEL IF AN ATTEMPT IS MADE TO OPEN THE DOOR.

THE INSTRUMENT PANEL COMPARTMENT DOOR LOCK IS ALSO OF THE FORK DESIGN, TO PREVENT THE DOOR ACCIDENTALLY OPENING IN THE EVENT OF A COLLISION.

WHEN LEAVING THE CAR THE DOORS ARE LOCKED BY SETTING THE BUTTON AND PUSHING THE DOOR CLOSED. THE HANDLE DOES NOT HAVE TO BE TOUCHED AS ON PREVIOUS MODELS.

CORROSION PROTECTION

BODY AND CHASSIS SHEET METAL IS SUBJECTED TO SPECIAL CORROSION PROTECTION PROCESSES. THE BODY DESIGN AVOIDS MUD AND WATER TRAPS TO ELIMINATE POTENTIAL CORROSION AREAS AND TO ASSIST IN MAXIMUM PAINT TO BODY PENETRATION. AT PANEL FABRICATION A ZINC RICH PRIMER IS APPLIED TO DOORS, TAILGATES, FENDERS, ENGINE HOOD, REAR BODY PILLARS AND DECK LID. AT THIS POINT A SOUND INSULATING BITUMINOUS MATERIAL IS SPRAYED ON THE INSIDE OF DOORS, DECK LID AND ROOF. THE BODY IS THEN DIP PRIMED TO A MINIMUM DEPTH OF 17.5", FOLLOWED BY A RED OXIDE PRIMER AND A BLACK FLASH PRIMER. BEFORE THE FINAL PAINT COATS ARE APPLIED THE FRONT AND REAR WHEELHOUSES ARE SPRAYED WITH A BITUMINOUS BASE PROTECTIVE MATERIAL, WHICH HELPS TO PROTECT AGAINST STONE DAMAGE AND NOISE. AFTER THE FINAL PAINT COATS HAVE BEEN APPLIED A WAX BASE CORROSION PREVENTATIVE COMPOUND "TECTYL" IS SPRAYED TO THE INSIDE OF DOORS, DOOR FRAMES, FRONT FENDERS, TAILGATES, DRIP GUTTERS, HOODS, FRONT PANEL, BUMPER FACE BARS AND UNDER MOULDINGS. FRONT AND REAR WINDOW SURROUNDS ARE PROTECTED BY AN OIL BASE PROCESS "BODY GUARD". DOORS ARE SUBJECTED TO AN ADDITIONAL RUST PREVENTATIVE PROCESS WHERE ACID RESISTANT ENAMEL IS APPLIED TO BOTTOM OF WEATHER-STRIP REBATE AREAS.

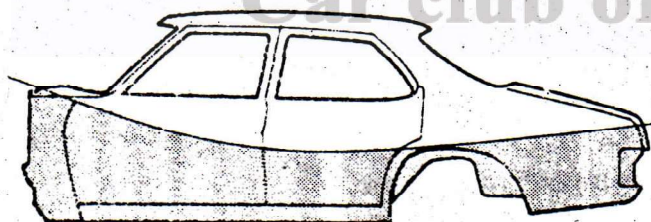

DIP PRIMER

TO IMPROVE ENGINE COMPARTMENT APPEARANCE ALL SHEET METAL AND MECHANICAL ITEMS ARE SPRAYED IN CLEAR LACQUER.

Issued: APRIL, 1977 Revised:

HOLDEN 'HZ' FEATURES

BODY

BUMPER BARS

BUMPER BARS ARE DESIGNED TO MINIMISE LOW SPEED IMPACT PANEL DAMAGE. BUMPER MOUNTINGS PROVIDE FOR A FRONT AND REAR BUMPER BAR JACKING SYSTEM FOR SEDANS.

AS AN ADDITIONAL PROTECTION REFINEMENT PREMIER STATESMAN DEVILLE AND STATESMAN CAPRICE FEATURE HORIZONTAL FRONT AND REAR BUMPER BAR RUB STRIPS.

PREMIER DEVILLE CALAIS AND CAPRICE MODELS FEATURE VERTICAL FRONT AND REAR RUBBER FACED BUMPER OVER-RIDERS.

SPARE WHEEL LOCATION

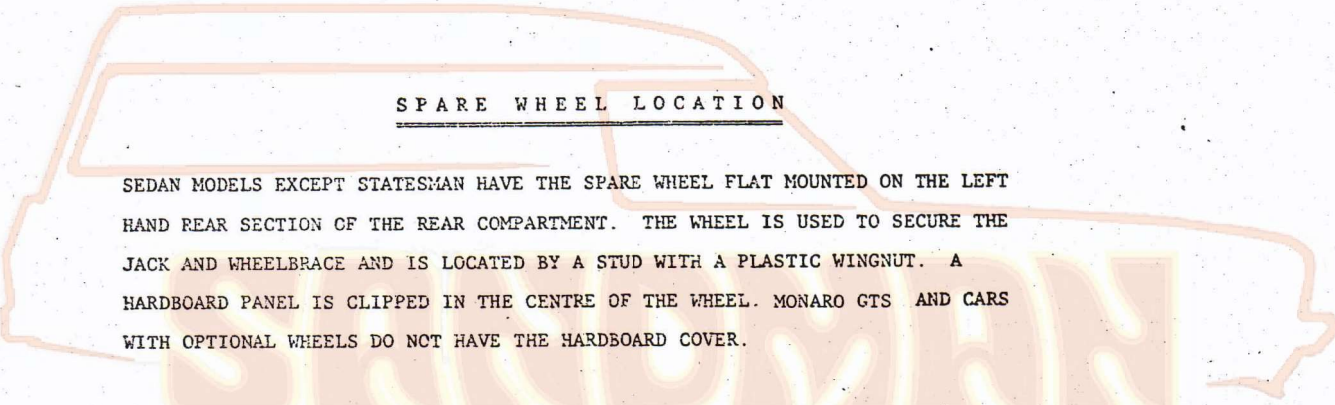

SEDAN MODELS EXCEPT STATESMAN HAVE THE SPARE WHEEL FLAT MOUNTED ON THE LEFT HAND REAR SECTION OF THE REAR COMPARTMENT. THE WHEEL IS USED TO SECURE THE JACK AND WHEELBRACE AND IS LOCATED BY A STUD WITH A PLASTIC WINGNUT. A HARDBOARD PANEL IS CLIPPED IN THE CENTRE OF THE WHEEL. MONARO GTS AND CARS WITH OPTIONAL WHEELS DO NOT HAVE THE HARDBOARD COVER.

STATION WAGONS HAVE THE WHEEL SECURED UNDER THE TONNEAU FLOOR.

STATESMAN MODELS HAVE THE WHEEL OBLIQUELY MOUNTED AT THE LEFT HAND FORWARD SIDE OF THE REAR COMPARTMENT. DEVILLE AND CALAIS MODELS HAVE A FULL P.V.C. COVER WHILE THE CAPRICE COVER IS CARPET.

COMMERCIAL VEHICLES HAVE THE SPARE WHEEL LOCATED UNDER THE LOAD FLOOR SUPPORTED BY A SMALL WINCH ACCESSIBLE THROUGH AN ACCESS HOLE IN THE REAR PANEL.

WINDSHIELD WIPERS AND WASHERS

THE SAFETY AND CONVENIENCE OF TWO SPEED ELECTRIC WINDSHIELD WIPER, DRIVER'S SIDE ARTICULATED WIPER ARM, BLACK GLARE REDUCED ARMS AND BLADES, AND FOUR JET SCREEN WASHING SYSTEM CONTINUES IN ALL 'HZ' MODELS. THE 'HZ' MODEL FEATURES A COLUMN MOUNTED WIPER/WASHER LIGHT CONTROL SWITCH. THIS CONTROL IS DESCRIBED ON PAGE C-15. WINDSHIELD WASHERS ARE DEMAND TYPE FOR 'HZ'. WIPERS SWITCH TO LOW WHEN BUTTON IS PRESSED AND WASHERS SPRAY A CONSTANT STREAM UNTIL BUTTON IS RELEASED.

Issued: APRIL, 1977 Revised:

HOLDEN 'HZ' FEATURES

BODY

FLOW-THROUGH VENTILATION

- THE FORCED AIR VENTILATION SYSTEM IS STANDARD ON ALL MODELS EXCEPT WHEN AIRCONDITIONING IS FITTED, HOWEVER, OUTSIDE BLOWN AIR VENTILATION IS ALSO A FEATURE OF THE AIRCONDITIONING SYSTEM WHICH IS STANDARD ON STATESMAN, CAPRICE AND DEVILLE AND OPTIONAL ON ALL OTHER MODELS.

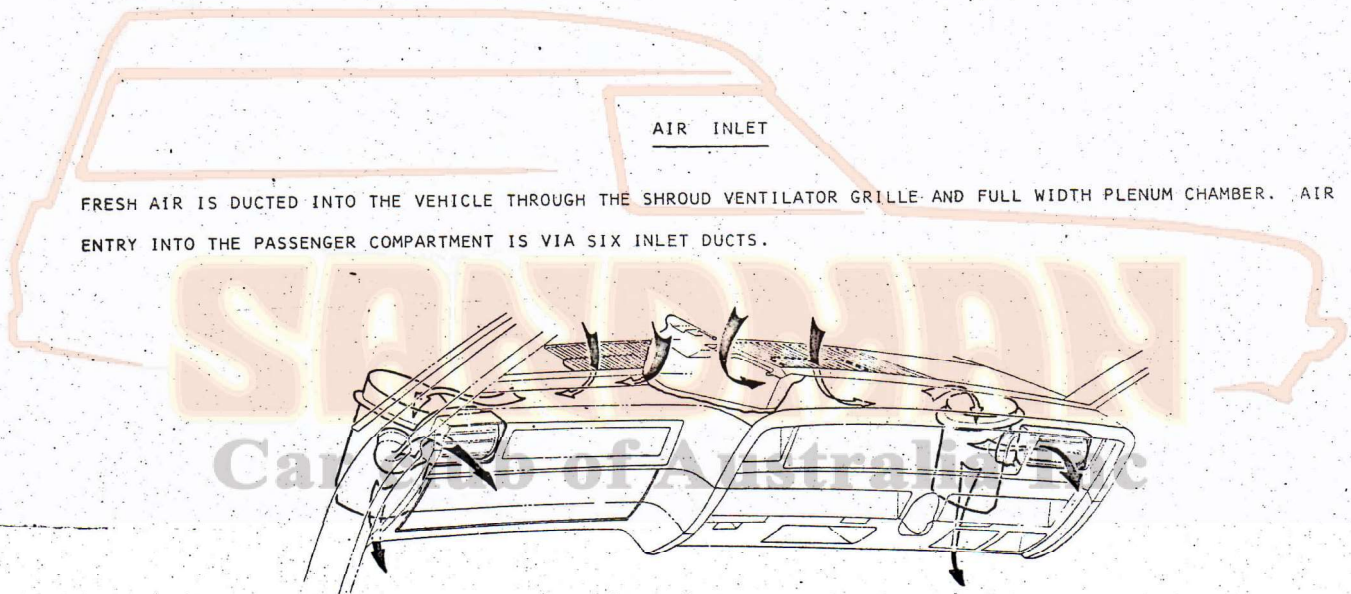

FRESH AIR IS DUCTED INTO THE VEHICLE THROUGH THE SHROUD VENTILATOR GRILLE AND FULL WIDTH PLENUM CHAMBER. AIR ENTRY INTO THE PASSENGER COMPARTMENT IS VIA SIX INLET DUCTS.

LOWER LEVEL VENTILATION

THERE ARE TWO INLETS LOCATED BELOW THE INSTRUMENT PANEL, ONE EITHER SIDE. THE AIR FLOW IS REGULATED BY CABLE OPERATED FLAP VALVES. CONTROL OF THESE VALVES IS BY MEANS OF HORIZONTAL SLIDING KNOBS ON THE INSTRUMENT PANEL EITHER SIDE OF THE STEERING COLUMN WHICH CAN BE REGULATED TO VARY THE FLOW OF INCOMING AIR TO THE DESIRED VOLUME OR CAN BE COMPLETELY CLOSED OFF.

UPPER LEVEL VENTILATION

CONSISTS OF:-

FOUR INLETS, ONE EITHER SIDE OF THE INSTRUMENT PANEL FOR RAM AIR, AND TWO INLETS LOCATED ON THE CENTRE OF THE INSTRUMENT PANEL FOR FORCED AIR VENTILATION ON ALL VEHICLES NOT FITTED WITH AIRCONDITIONING.

THE AIR FLOW DIRECTION IS CONTROLLED BY HORIZONTALLY SWIVELLING VANES IN THE VENTS. A THUMB WHEEL CONTROL HAS A DUAL PURPOSE OF COMPLETELY CLOSING OFF THE UPPER LEVEL VENTILATION, OR DIRECTING THE AIR FLOW TO THE PREFERENCE OF THE OCCUPANTS.

Issued: APRIL, 1977 Revised: JULY, 1978

HOLDEN 'HIZ' FEATURES



BODY

FLOW-THROUGH VENTILATION (CONTINUED)

FORCED AIR VENTILATION

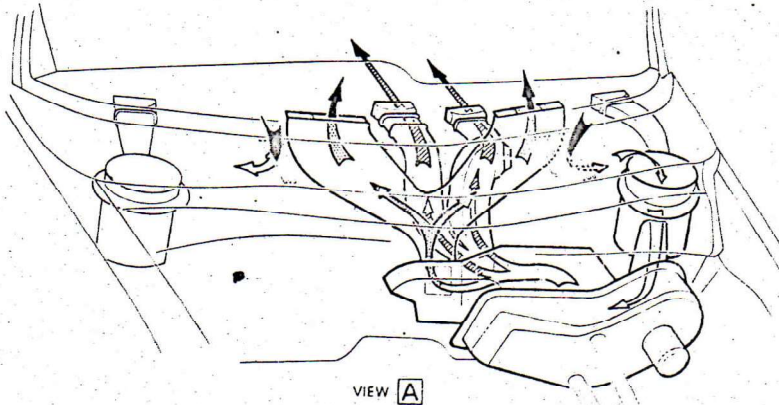
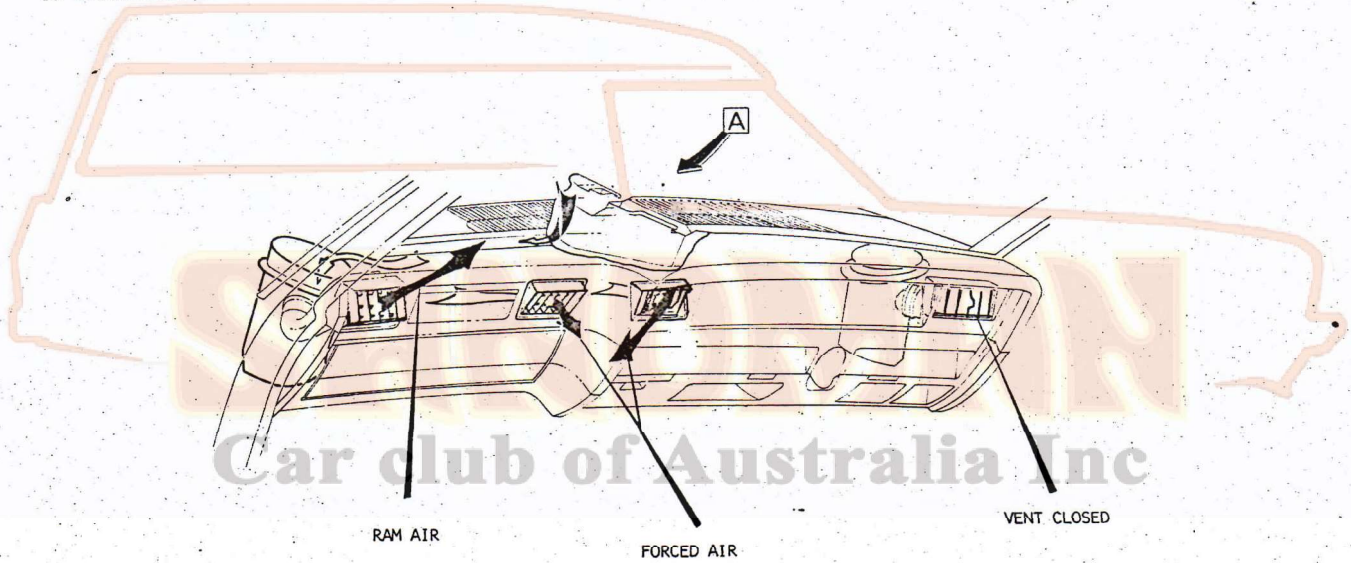
THE ADVANTAGE OF THE FORCED AIR VENTILATION IS THAT IT ALLOWS AN INCREASED VOLUME OF OUTSIDE AMBIENT AIR TO ENTER THE PASSENGER COMPARTMENT THROUGH TWO ADDITIONAL UPPER LEVEL VENTS LOCATED IN THE CENTRE OF THE INSTRUMENT PANEL. THIS SYSTEM CAN BE OPERATED WHILE STATIONARY OR MOVING AT A SLOW SPEED, OR USED TO SUPPLEMENT THE NORMAL RAM AIR SYSTEM. VOLUME OF AIR IS CONTROLLED BY SELECTING EITHER OF THE TWO FAN SPEEDS. ON STATESMAN CAPRICE AND CALAIS OR VEHICLES EQUIPPED WITH OPTIONAL AIRCONDITIONING, BLOWN AIR IS DISCHARGED THROUGH ALL FOUR VENTS, VOLUME OF AIR BEING CONTROLLED BY SELECTING ANY OF FOUR FAN SPEEDS.



-  DEMIST ROUTE.
-  UPPER LEVEL VENT ROUTE.

Issued: APRIL, 1977 Revised:

HOLDEN 'H2' FEATURES

BODY

FLOW-THROUGH VENTILATION (CONTINUED)

PRESSURE RELIEF

PRESSURE RELIEF VALVES ARE LOCATED ON THE REAR DOOR LOCK PILLARS. THESE ACT AS EXHAUST OUTLETS TO ATMOSPHERE FOR STALE AIR. THE ACTION OF THE VALVES IS SUCH THAT THE VEHICLE INTERIOR IS SLIGHTLY PRESSURISED AND THUS AIDS PREVENTION OF DUST ENTRY.

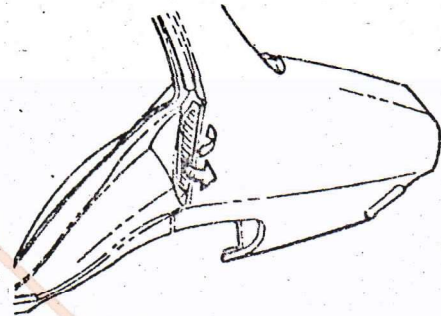

PRESSURE RELIEF AIR OUTLET

SANDMAN

DIAGRAMS SHOWING THE AIR CIRCULATION ROUTE IN VARIOUS BODY STYLES

Car club of Australia Inc

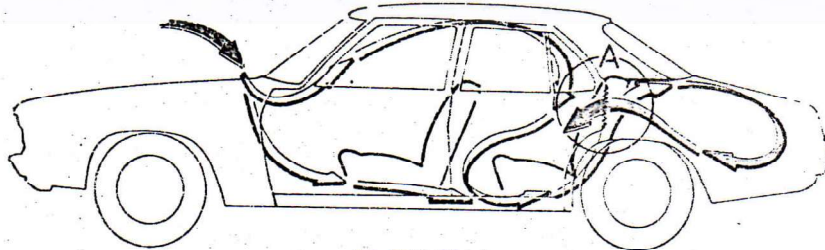

69 STYLES

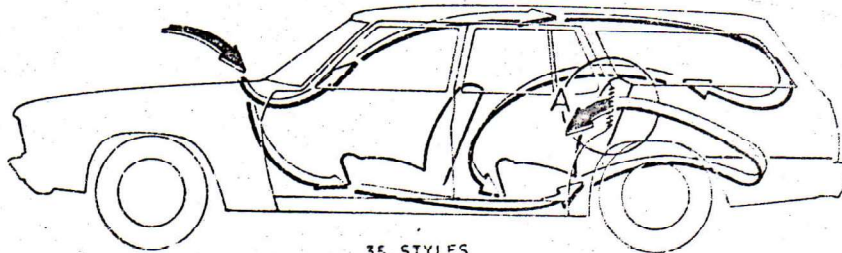

35 STYLES

SHADED SECTION OF ARROW SHOWS AIR FLOWING BETWEEN INNER AND OUTER PANNELS.



Issued:

Revised:

HOLDEN 'H2' FEATURES

BODY

'AIRMIX' HEATING SYSTEM

A TWO SPEED FAN BOOSTED HEATER AND DEMISTER UNIT IS A STANDARD FITMENT ON ALL 'H2' MODELS. HEAT CONTROL IS VARIED BY MIXING COLD AIR WITH HEATED AIR TO PROVIDE THE DESIRED TEMPERATURE WHICH IS KNOWN AS THE 'AIRMIX' PRINCIPLE.

HEAT OUTLET









CONNECTED INTO THE UNDER DASH FLOW-THROUGH DUCT IS A CENTRAL VENT THAT SERVES AS THE OUTLET FOR HEATED AIR WHICH IS EQUALLY AND BROADLY DISTRIBUTED ACROSS THE FULL WIDTH OF THE PASSENGER COMPARTMENT AT FLOOR LEVEL. NO HOT AIR IS DISCHARGED THROUGH THE UPPER LEVEL VENTS WHILE IN THE HEATING MODE.

HEAT CONTROL

HOT WATER FROM THE ENGINE COOLING SYSTEM IS DIRECTED TO A HEATER CORE IN THE MAIN DUCT AIRSTREAM. A CABLE OPERATED HEAT DOOR DIRECTS INCOMING AIR THROUGH THE HEATER CORE IN THE HEATING MODE, AND DIVERTS THE COLD INCOMING AIR PAST THE HEATER CORE WHEN THE HEATER IS NOT IN OPERATION. THE POSITION OF THE HEAT DOOR IS VARIABLE SO THAT A MIXTURE OF HOT AND COLD AIR WILL PRODUCE THE REQUIRED DEGREE OF WARMTH. WITH THE CONTROL IN THE HEAT MODE, TEN PER CENT OF HOT AIR IS FED TO THE DEMIST DUCTS.

DEMISTING

A LARGE TWO BRANCH DEMIST DUCT EXTENDING THE FULL WIDTH OF THE WINDSHIELD IS ALSO CONNECTED INTO THE DUCT SYSTEM. WITH THE CONTROL IN THE DEMIST MODE ALL THE HOT AIR IS DIRECTED TO THE WINDSHIELD FOR RAPID DEMISTING.

-  FAN
-  FAN OFF OR VENT CLOSED
-  LOW SPEED
-  HIGH SPEED
-  PASSENGER COMPARTMENT
-  WINDSCREEN DEMIST
-  BLUE - COLD
-  RED - HOT
-  FORCED VENTILATION VENTS

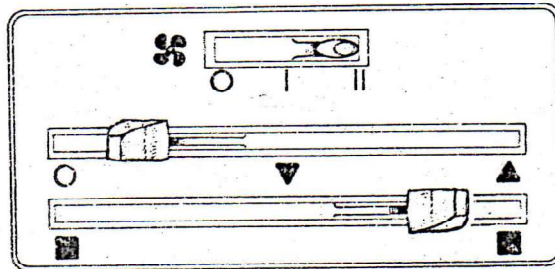

HEATER DEMISTER
CONTROLS

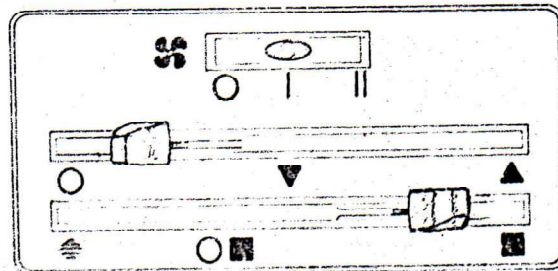

HEATER DEMISTER AND
FORCED AIR CONTROLS

Issued: APRIL, 1977 Revised:

HOLDEN 'HZ' FEATURES

BODY

FULLY INTEGRATED AIR-CONDITIONING SYSTEM

A FULLY INTEGRATED AIRCONDITIONING SYSTEM IS STANDARD EQUIPMENT ON BOTH STATESMAN CAPRAOE AND DEVILLE AND IS OPTIONAL ON ALL OTHER MODELS. THE SYSTEM IS DESIGNED TO COMBINE BOTH THE SEPARATE COOLING AND HEATING FUNCTION INTO A SINGLE UNIT TO SIMULTANEOUSLY CONTROL BOTH THE HEATING AND AIRCONDITIONING OF THE VEHICLE. THUS THE AIR MAY BE COOLED, HEATED OR BOTH COOLED AND RE-HEATED BY THE 'AIRMIX' PRINCIPLE.

THE REFRIGERATING COMPONENTS LOCATED IN THE ENGINE COMPARTMENT ARE OF THE USUAL TYPE INCLUDING THE WELL PROVEN FRIGIDAIRE DOUBLE ACTING PISTON/SWASH PLATE DESIGN OF COMPRESSOR WHICH IS BELT DRIVEN THROUGH A MAGNETIC CLUTCH.

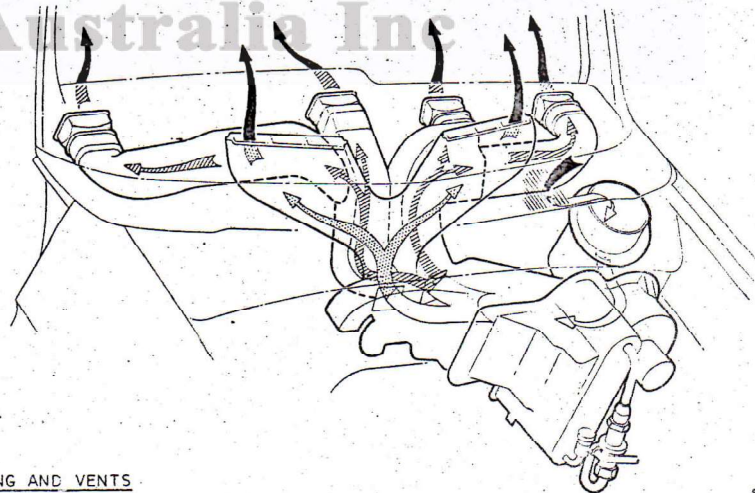
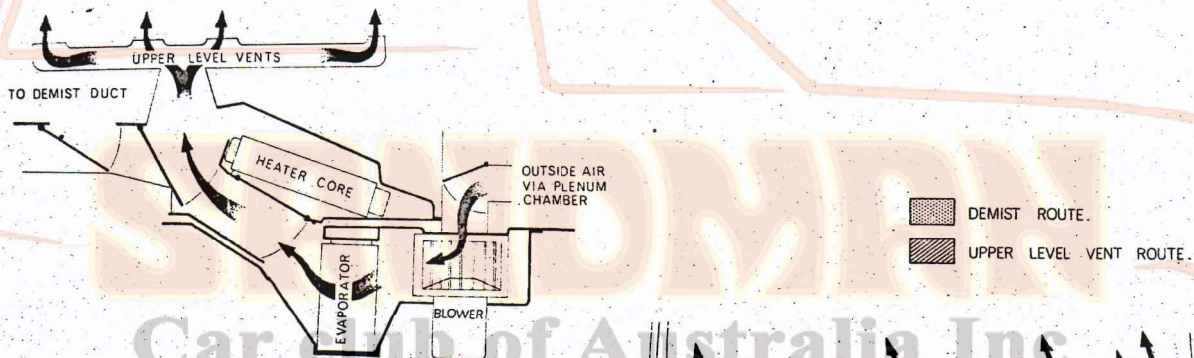

DUCTING AND VENTS

THE UNDERDASH DUCT ARRANGEMENT AND UPPER LEVEL VENTS ARE DIFFERENT TO THAT USED FOR THE FLOW-THROUGH VENTILATION SYSTEM. THE SIDE VENTS HAVE FULLY ADJUSTABLE VERTICAL AND HORIZONTAL DIRECTIONAL VANES AND TWO VERTICALLY ADJUSTABLE VANE OUTLETS ARE FITTED IN THE CENTRE OF THE INSTRUMENT PANEL PAD FOR IMPROVED AIR DISTRIBUTION TO THE REAR COMPARTMENT. THE FOUR VENTS ARE DIRECTLY CONNECTED TO THE AIR-CONDITIONING SYSTEM DIFFERENTLY ARRANGED UNDER DASH DUCTING, THIS PROVIDES INDIVIDUAL ADJUSTMENT FOR BOTH DRIVER AND PASSENGER.

COOLING CORE

IN ADDITION TO THE CLOSED CIRCUIT HEATER COPE WHICH IS CONNECTED TO THE ENGINE COOLING SYSTEM, THERE IS ALSO A COOLING COPE THROUGH WHICH ALL AIR MUST PASS. AS THE AIR PASSES THROUGH THE COOLING CORE IT IS WASHED FREE OF DUST AND POLLEN AND THE EXCESS MOISTURE REMOVED AND DRAINED AWAY.

Issued: APRIL, 1977 ■ Revised: JULY, 1978

HOLDEN 'HIZ' FEATURES

BODY

FULLY INTEGRATED AIR-CONDITIONING SYSTEM (CONTINUED)

FAN

- THE AIR FLOW THROUGH THE SYSTEM IS CONTROLLED WITH A FOUR SPEED FAN, AND IS OPERATED BY THE SWITCH LOCATED ON THE UPPER SECTION OF THE AIR-CONDITIONER CONTROL PANEL ON RIGHT OF STEERING COLUMN. THE FAN LEVER HAS FOUR POSITIONS FROM 'I' AT THE LEFT TO 'IIII' AT THE RIGHT. THE FAN IS OPERATIONAL AUTOMATICALLY WHEN IGNITION IS SWITCHED 'ON' REGARDLESS OF LEVER POSITION WITH THE EXCEPTION OF THE '0' (OFF) POSITION ON MODE SELECTOR LEVER WHEN THE COMPLETE SYSTEM IS NON-FUNCTIONAL.

TEMPERATURE CONTROL (LOWER LEVER)

- THE CENTRE LEVER ON THE AIR-CONDITIONER CONTROL PANEL VARIES THE TEMPERATURE OF THE AIR AT THE OUTLETS FROM A MINIMUM OF 40°F (5°C) TO A MAXIMUM OVER 100°F (38°C) IF DESIRED. MOVEMENT OF THE LEVER AWAY FROM THE COLD POSITION WILL VARY THE AIR TEMPERATURE. THE OUTLET TEMPERATURE IS ADJUSTED FOR MAXIMUM COMFORT BY MOVING THE LEVER TO AN INTERMEDIATE POSITION BETWEEN COLD (BLUE ZONE) AND HOT (RED ZONE).

MODE OR UPPER SELECTOR LEVER OPERATION

- THIS POSITION SHUTS THE ENTIRE SYSTEM OFF, INCLUDING BLOWER FAN.

- AIR FROM THE PASSENGER COMPARTMENT IS RECIRCULATED THROUGH THE SYSTEM AND DISCHARGED THROUGH THE CENTRE OUTLET VENTS LOCATED ON THE INSTRUMENT PANEL. THIS POSITION IS USED FOR RAPID 'COOL-DOWN' OF CAR INTERIOR, OR WHEN MAXIMUM COOLING IS REQUIRED, IT CAN ALSO BE USED TO BLOCK OUT OBNOXIOUS FUMES.

- OUTSIDE AIR IS BLOWN THROUGH THE SYSTEM, REFRIGERATED AND DISCHARGED THROUGH UPPER VENTS LOCATED ON THE INSTRUMENT PANEL INTO CAR INTERIOR. NO RECIRCULATION OF THE AIR IS POSSIBLE IN THIS POSITION. THE COOLED DRYER AIR MAY THEN BE HEATED AS DESIRED TO PROVIDE A COMFORTABLE TEMPERATURE. THE AIR IS THEN DISCHARGED FROM THE VEHICLE THROUGH PRESSURE RELIEF VALVES LOCATED IN REAR BODY PILLARS.

- THIS POSITION IS FORCED VENT AND INTAKES AMBIENT AIR IN THE SAME WAY AS  BUT IS NOT REFRIGERATED. THIS POSITION SHOULD BE USED FOR SOME MINUTES WITH WINDOW OPEN AFTER A PERIOD OF HOT SOAK.

- OUTSIDE AIR IS DIRECTED THROUGH DEMISTER DUCTS FOR MAXIMUM DEMISTING OF THE WINDSHIELD. AIR TEMPERATURE IS VARIED BY MOVEMENT OF THE TEMPERATURE LEVER.

- AMBIENT OUTSIDE AIR IS DISCHARGED THROUGH LOWER OUTLETS INTO THE PASSENGER COMPARTMENT. TEMPERATURE OF THE AIR IS CONTROLLED BY ADJUSTING THE TEMPERATURE LEVER TO OBTAIN OPTIMUM COMFORT. A PROPORTION OF THIS AIR IS BLEND THROUGH DEMISTER DUCT TO MAINTAIN A CLEAR WINDSHIELD.

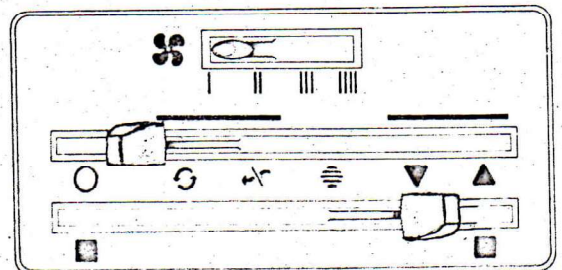

Issued: OCTOBER, 1975

Revised: APRIL, 1977

HOLDEN 'HIZ' FEATURES

BODY

FRONT SEAT BELTS

ALL FRONT SEAT PASSENGER POSITIONS ARE PROVIDED WITH A SEAT BELT. FRONT SEAT OUTER BELTS ARE OF THE DUAL SENSITIVE RETRACTABLE INERTIA REEL TYPE WITH THE RETRACTOR MOUNTED ON THE CENTRE PILLAR. ON MODELS WITH A BENCH FRONT SEAT THE CENTRE PASSENGER HAS A LAP BELT, WITH ONE POINT ADJUSTMENT AT THE TONGUE. ALL OUTBOARD FEMALE BUCKLES ARE MOUNTED ON FORMABLE STEEL STALKS WITH THE BELT RELEASE BUTTON INCORPORATED IN THE BUCKLE. THE STALK IS MADE FROM PLASTIC COVERED FORMABLE STEEL CABLE. THE STALK CAN BE REPOSITIONED WITH LIGHT PRESSURE WHILE STILL REMAINING SELF SUPPORTING, TO ENABLE EASE OF CONNECTING BELTS.

Car club of Australia Inc

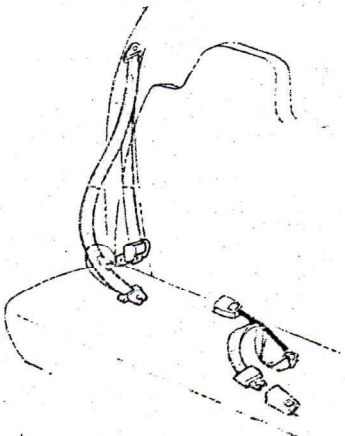

SEDAN AND STATION WAGON
WITH FRONT BENCH SEAT

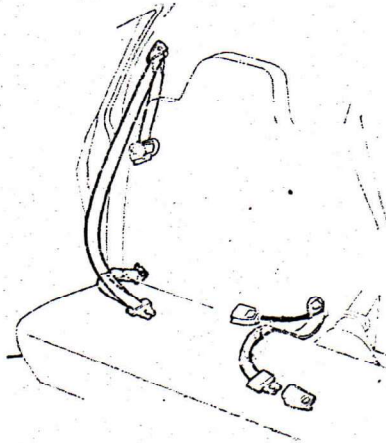

HOLDEN COMMERCIAL

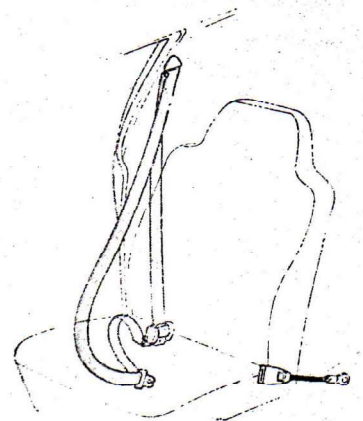

SEDAN AND STATION WAGON
WITH BUCKET SEATS

Issued: OCTOBER, 1975

Revised: APRIL, 1977

HOLDEN 'HZ' FEATURES

BODY

REAR VISION MIRRORS

REAR VISION MIRRORS ON THE 'HZ' MODELS ARE A CARRYOVER ITEM FROM 'HX'. ALL MODELS FEATURE GLARE REDUCED EXTERNAL MIRRORS, AND EITHER GLARE REDUCED OR PRISMATIC "DAYLIGHT" INTERNAL MIRRORS. ALL INTERNAL MIRRORS ARE MOUNTED ON A SAFETY TYPE, SPRING LOADED, KNOCK-OUT MOUNTING.

EXTERIOR MIRRORS

REMOTE CONTROL EXTERIOR MIRROR

THE "REMOTE CONTROL, CABLE OPERATED MIRROR" IS MOUNTED ON THE FORWARD SECTION OF THE FRONT DOOR. A FIXED RECTANGULAR KNOCK PROOF HOUSING PROTECTS THE MIRROR. ADJUSTMENT IS BY A CABLE CONTROL ON THE UPPER LEADING EDGE OF THE INNER DOOR TRIM. THE VISION AREA IS 5.7" X 3.9" (145MM X 99MM).

■ KINGSWOOD SL, -PREMIER, DEVILLE AND CAPRICE HAVE A REMOTE CONTROL MIRROR AS STANDARD EQUIPMENT.

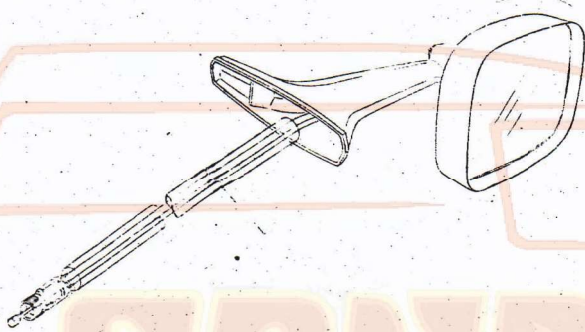

■ KINGSWOOD A9K

A MANUAL ADJUSTMENT RECTANGULAR MIRROR IS MOUNTED ON THE FORWARD SECTION OF THE DRIVER'S DOOR.

THE VISION AREA IS 5.5" X 4" (136 X 102 MM.).

PANEL VAN, UTILITY AND CHASSIS CAB

MANUAL ADJUSTMENT RECTANGULAR MIRRORS ARE MOUNTED ON THE FORWARD SECTION OF THE DRIVER'S AND PASSENGER'S DOORS. THE CHASSIS CAB HAS OUTWARD EXTENDED MOUNTING ARMS TO ENSURE REAR VISION AT MAXIMUM BODY WIDTH. THE VISION AREAS ARE :-
5.5" X 4" (136 X 102 MM.) - PANEL VAN & UTILITY
6.5" X 4.6 (165 X 117 MM.) - CHASSIS CAB.

MONARO GTS & SANDMAN

THE MONARO GTS HAS TWO MIRRORS MOUNTED IN MATT BLACK FIXED STREAMLINED HOUSING. ADJUSTMENT IS BY MOVING THE PIVOTED GLASS MANUALLY. MIRROR HEIGHT CAN BE ALTERED BY ADJUSTING THE MOUNTING BOSS. THE VISION AREA IS 5.0" X 3.0" (127 X 36 MM)

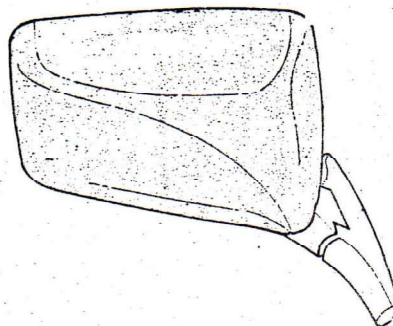
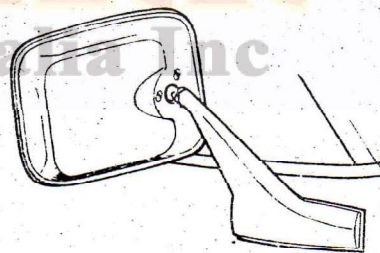

INTERIOR MIRRORS

STATESMAN, PREMIER AND MONARO GTS

A PRISMATIC "DAYLIGHT" TYPE RECTANGULAR MIRROR WITH VERTICAL ADJUSTMENT TO SUIT DRIVER'S HEIGHT IS FITTED. THE VISION AREA IS 2" X 10" (51 X 254 MM.)

KINGSWOOD, HOLDEN AND KINGSWOOD PANEL VAN & UTILITY

A VERTICALLY ADJUSTABLE GLARE REDUCED RECTANGULAR MIRROR IS FITTED. THE VISION AREA IS 2" X 10" (51 X 254 MM.)

Issued: APRIL, 1977 ■ Revised: JULY, 1978

HOLDEN 'H2' FEATURES

BODY

REAR SEAT BELTS

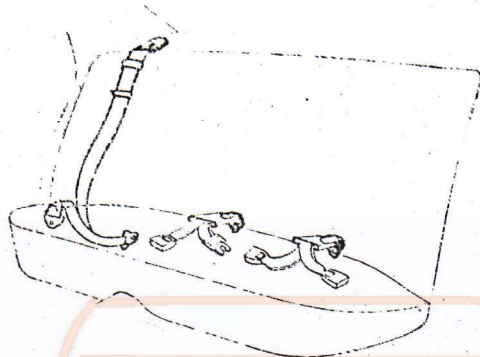

SEDAN

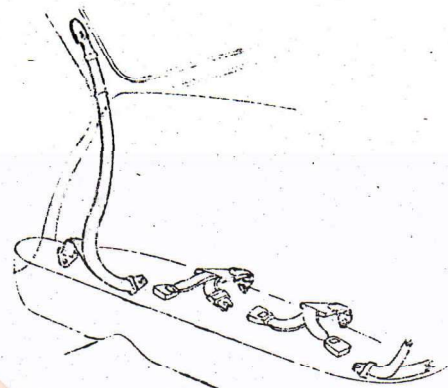

STATION WAGON

REAR SEAT BELTS

ALL MODELS ARE PROVIDED WITH A SEAT BELT FOR EACH SEATING POSITION. THE OUTER BELTS ARE LAP SASH WITH ONE POINT ADJUSTMENT ON THE UPPER SECTION OF THE SASH. THE INNER BELTS ARE LAP TYPE WITH A ONE POINT ADJUSTMENT ADJACENT ON THE TONGUE BELT. THE STATION WAGON UPPER MOUNTING IS POSITIONED ON THE REAR BODY PILLAR, ALLOWING THE REAR SEAT TO BE FOLDED WITHOUT TANGLING THE BELTS. THE COVER FOR THE UPPER SASH MOUNTING INCORPORATES A STOWAGE HOOK.

STOWAGE HOOK



CHILD RESTRAINT SYSTEMS

PROVISION IS AVAILABLE FOR THE INSTALLATION OF CHILD RESTRAINT SYSTEMS AT 3 POINTS ON THE PARCEL SHELF OF SEDANS AND THE FORWARD TONNEAU FLOOR ON STATION SEDANS.

STATESMAN CAPRICE

THE STATESMAN CAPRICE REAR SEAT IS FITTED WITH DUAL SENSITIVE RETRACTABLE BELTS ON THE OUTER POSITIONS. THESE BELTS ARE AVAILABLE AS AN OPTION ON ALL SEDAN MODELS. THE CENTRE BELT REMAINS A LAP TYPE.

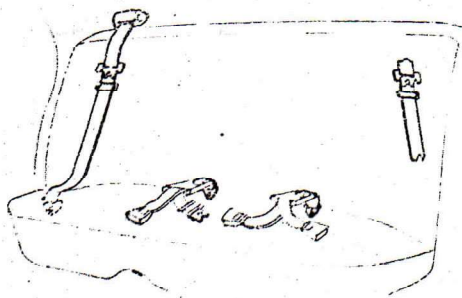

STATESMAN CAPRICE & OPTIONAL EQUIPMENT (SEDAN STYLES ONLY)

Issued: APRIL, 1977

Revised:

HOLDEN 'HIZ' FEATURES

MECHANICAL

INDEX TO SECTION E

INTRODUCTION	E - 1
FRAME	E - 2
FRONT SUSPENSION, BRAKES	E - 3
REAR AXLE, REAR SUSPENSION	E - 4
BRAKES	E - 5
ENGINES	E - 6
TRANSMISSIONS	E - 7
FUEL TANK, IGNITION STEERING LOCK, KEYS	E - 8
STEERING MANUAL AND POWER	E - 9
WHEELS AND TYRES	E - 10
EXTERNAL LAMPS	E - 11
INTERNAL LAMPS	E - 12
EMISSION CONTROLS	E - 13 to E -16

Issued: MAY, 1977

Revised:

HOLDEN 'HZ' FEATURES

MECHANICAL

INTRODUCTION

The major feature changes to 'HZ' are mechanical.

The objectives of improved ride and handling on all GMH manufactured vehicles first introduced on the Holden Sunbird is followed through to 'HZ' resulting in a complete character change to all models. This feature is highlighted by 'Radial Tuned Suspension' badges on all models.

THE DESIGN OBJECTIVES WERE :

RIDE - SUSPENSION IMPROVEMENTS

- To improve ride comfort, through a stiffer and flatter ride.
- To reduce vehicle noise, impact harshness and shake.
- To reduce the level of axle hop and shock absorber fade which occurs on broken road surfaces.

DURABILITY - SUSPENSION IMPROVEMENTS

- To improve durability of critical chassis components.
- To improve tyre mileage/cost ratio.

HANDLING - SUSPENSION IMPROVEMENTS

- To improve vehicle handling on all types of road surfaces and under all load conditions.
- To reduce vehicle roll when cornering.
- To improve straight ahead stability.
- To improve load carrying capability and eliminate the need for separate outback, Taxi and Towing suspensions.

STEERING - IMPROVEMENTS

- To improve steering response, returnability and on centre feel for both manual and power steering.
- To improve power steering parking effort with brakes on.
- To give power steering the European feel.

THE RADIAL TUNED SUSPENSION REVISION CONSISTS OF :

- o Relocated front suspension upper control arm bracket to allow new wheel alignment geometry.
- o Revised characteristics for front lower control arm bushes.
- o Modified rate rear axle control arm bushes on passenger models.
- o New front and rear springs and revised ride height.
- o Tuned front and rear shock absorbers.
- o Increased piston diameter on all rear shock-absorbers and on front shock absorbers for certain models.
- o New shock-absorber upper attachment front and rear.
- o Larger front suspension bump rubber.
- o Increased diameter front stabilizer bar, (common with GTS), on all models.
- o Rear stabiliser bar fitted to all models.
- o 6.00Jx14" wheels fitted to all models with changed offset to give a wider track, except chassis cab. GTS wheels are carryover.
- o Radial tyres are fitted to all models. Steel belted on base passenger models and Chassis Cab. Textile belted on Kingswood (A9K), Panel Van and Utility.
- o Stiffer bushes in steering linkage connecting rod.
- o Revised power steering gear and revised power steering pump.
- o New wheel alignment specifications incorporating positive instead of negative caster angles and specific adjustments for manual and power steering.

Both the partial front frame and full commercial frames are constructed of lighter gauge material to reduce weight, improve durability and reduce lateral body shake. The passenger frame mounts on all models are now 6 (six) as used on 'HX' Kingswood and Belmont and with the deletion of these mounts the frame extensions are shortened. Commercial frames, Taxis and Outback option frames are fitted with a frame brace in the engine bay area to further improve durability.

4 Wheel disc brakes are introduced as standard on Monaro GTS and Statesman models. The availability of rear disc brakes in lieu of drum brakes is optional on all other models except Chassis Cab. The anti-lock rear drum brake system is optional on all Statesman models and, is now available with 2.60, 3.98 and 3.36 rear axle ratios.

Issued: MAY, 1977

Revised: JUNE, 1977

HOLDEN 'HZ' FEATURES

NO CURVES
NO ENERGY

MECHANICAL

FRAME

THE FRAME FOR 'HZ' IS CONSTRUCTED OF LIGHTER GAUGE MATERIAL TO REDUCE WEIGHT. THIS HAS RESULTED IN REDUCTION OF LATERAL BODY SHAKE AND AN IMPROVEMENT IN DURABILITY.

ALL PASSENGER MODELS NOW HAVE 6 (SIX) BODY MOUNTINGS AND THE EXCESS FRAME LENGTH IS DELETED TO FURTHER SAVE WEIGHT.

A BRACE IS FITTED BETWEEN THE SUSPENSION CROSSMEMBER AND THE FRAME SIDEMEMBER ON EACH SIDE TO TRIANGULATE THE FRAME ON COMMERCIAL VEHICLES, TAXIS AND OUTBACK PACKAGE OPTION.

THE FRAME UPPER CONTROL ARM BRACKET IS RELOCATED TO ALLOW IMPROVEMENTS TO THE SUSPENSION GEOMETRY.

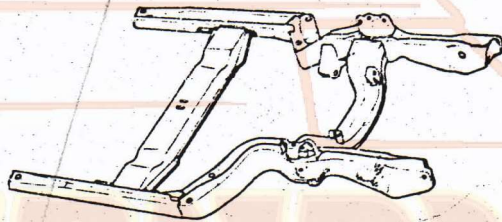

PASSENGER VEHICLES - PARTIAL FRAME

THE PARTIAL FRONT FRAME IS USED ON ALL PASSENGER VEHICLES. THE ENGINE, TRANSMISSION AND FRONT SUSPENSION ARE MOUNTED ON THIS FRAME AND ISOLATED FROM THE PASSENGER COMPARTMENT.

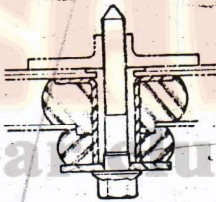

BODY TO FRAME MOUNTING

THE 'HZ' FRAME IS ATTACHED TO THE BODY BY RUBBER MOUNTINGS.

PANEL VAN & UTILITY	12 POINTS
CHASSIS CAB	8 "
SEDANS & STATION WAGONS	6 "

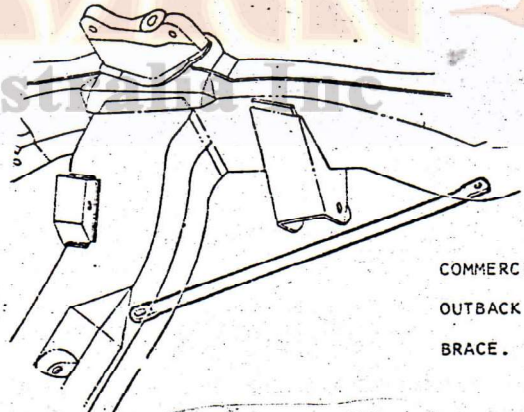

COMMERCIAL TAXI AND OUTBACK OPTION FRAME BRACE.

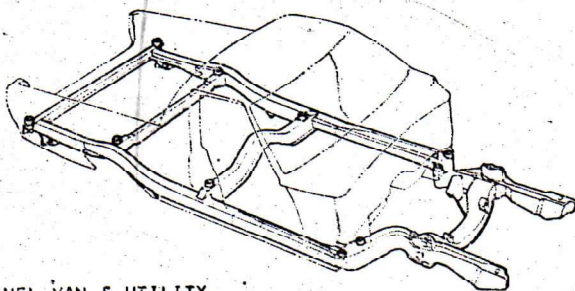

PANEL VAN & UTILITY

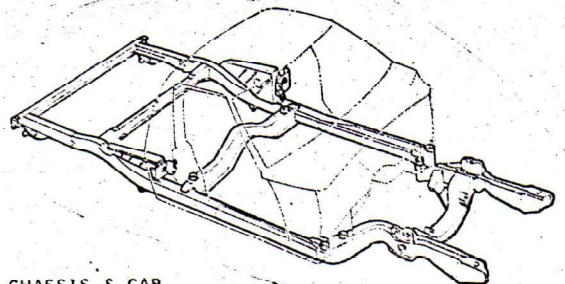

CHASSIS & CAB

COMMERCIAL VEHICLES - FULL FRAME

THE SAME BASIC PASSENGER CAR FRONT FRAME IS UTILIZED FOR COMMERCIAL VEHICLES WITH THE ADDITION OF REAR SIDE BARS AND INNER BOXING MEMBERS FORMING A FULL PERIMETER FRAME TO COPE WITH THE INCREASED WORK LOAD OF A COMMERCIAL VEHICLE.

Issued: MAY, 1977 Revised:

HOLDEN 'HZ' FEATURES

MECHANICAL

FRONT SUSPENSION

NO
CHANGE
Nomenclature.

THE HZ FRONT SUSPENSION AREA HAS BEEN THE CENTRE OF DEVELOPMENT OF THE RIDE AND HANDLING IMPROVEMENTS.

OTHER AREAS COMPLEMENTING THE FRONT SUSPENSION IMPROVEMENTS ARE LIGHT WEIGHT CHASSIS AND SHOCK ABSORBER UPPER MOUNTINGS, STEERING LINKAGE, STEERING COLUMN MOUNTING, WHEELS AND TYRES.

WHILE BASICALLY USING THE SAME COMPONENTS AS HX THE HZ FRONT SUSPENSION EFFICIENCY HAS BEEN GREATLY IMPROVED BY ALTERING THE FOLLOWING ITEMS :-

RELOCATING THE FRONT UPPER CONTROL ARM BRACKET

- TO - REDUCE UNDERSTEER
- REDUCE ROLL STEER VARIATION
- REDUCE CAMBER & TOE CHANGE ON BUMP & CORNERING
- ACHIEVE POSITIVE INSTEAD OF NEGATIVE CASTER ANGLES
- IMPROVE HANDLING
- IMPROVE ON CENTRE FEEL
- IMPROVE STRAIGHT AHEAD STABILITY

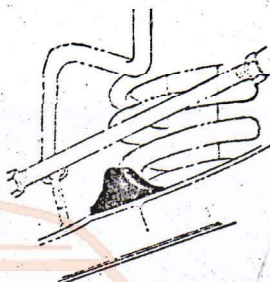

HX

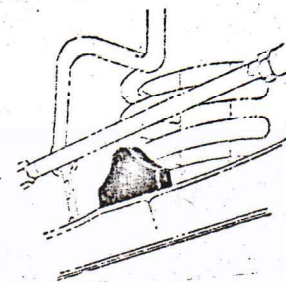

HZ

NEW HIGHER LOAD FRONT SPRINGS (STIFFER ON V8 CARS)

- TO - INCREASE GROUND CLEARANCE
- IMPROVE RIDE
- REDUCE SPRING BOTTOMING

NEW BUMP RUBBER TO -

- PREVENT METAL TO METAL CONTACT
- IMPROVE DYNAMIC GROUND CLEARANCE

INCREASED DIAMETER STABILIZER BAR (ALL MODELS SAME AS HX GTS)

- TO - REDUCE BODY ROLL
- OPTIMISE ROLL COUPLE DISTRIBUTION FRONT TO REAR FOR IMPROVED HANDLING

TUNED FRONT LOWER CONTROL ARM BUSHES (FRONT BUSH - RADIALLY HARD - LONGITUDINALLY SOFT. REAR BUSH - RADIALLY INTER-MEDIATE HARDNESS - LONGITUDINALLY SOFT)

- TO - PROVIDE LONGITUDINAL LOAD COMPLIANCE UP TO PRE-DETERMINED LEVEL BEFORE PROGRESSIVELY HARDENING. THIS ACHIEVES IMPROVED CONTROL ROAD SHOCK DAMPENING WITHOUT DETRIMENT TO HANDLING AND VEHICLE RESPONSE.

NEW SHOCK ABSORBER ATTACHMENTS

- TO - IMPROVE ROAD HOLDING
- IMPROVE DURABILITY
- REDUCE NOISE TRANSMITTANCE

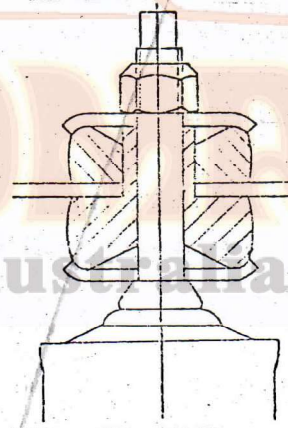

HX

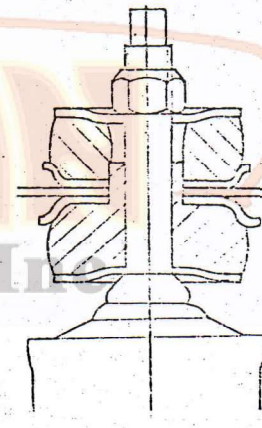

HZ

UPPER SHOCK ABSORBER MOUNTING

RELOCATED UPPER CONTROL ARM BRACKETS TO ALLOW POSITIVE CASTER ANGLE.

(HX POSITION IN GHOST OUTLINE)

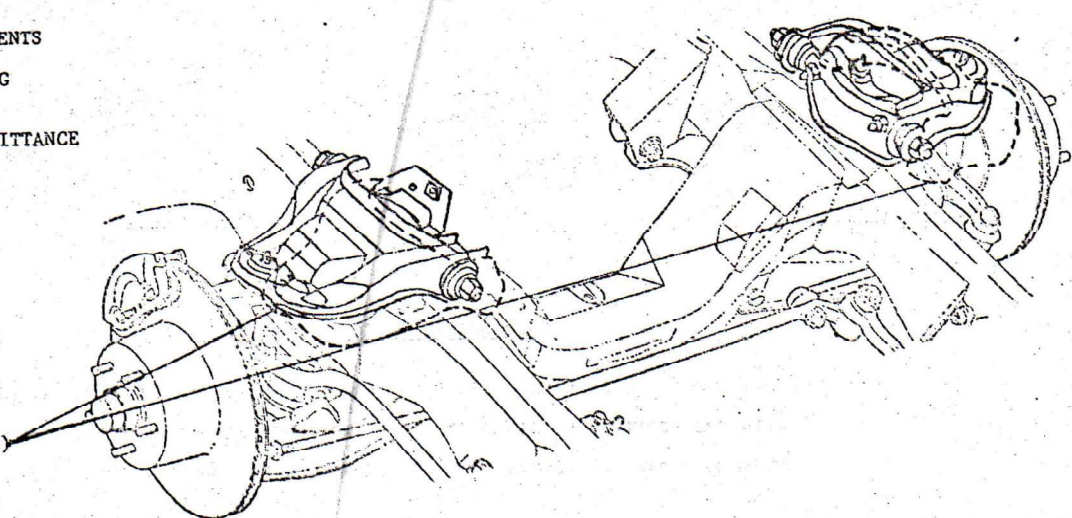

Issued: MAY, 1977

Revised:

HOLDEN 'HZ' FEATURES

MECHANICAL

REAR AXLE AND SUSPENSION

~~The~~ ^{ARE} two types of rear axle used ~~and continued~~ ^{WB} on high load capacity with long bearing life. ^{HAVE ROLLED SPINES &} All axle shafts are fitted with taper roller bearings to achieve high load capacity with long bearing life.

The Salisbury type rear axle is used to accommodate the high power output of the V8 engines and the load carrying capacity of the Chassis and Cab.

~~The Banjo type rear axle remains unchanged and is fitted to all 6 cylinder models except Chassis and Cab.~~
~~THE INTRODUCTION OF THE 178mm SALISBURY AXLE ON WB COMPLETES THE USEAGE OF THIS TYPE OF AXLE ON ALL HOLDEN VEHICLES.~~

REAR AXLE RATIO AVAILABILITY

V8 Salisbury type	2.60, 3.08, 3.36, 3.55
6 Cylinder Banjo type	3.08, 3.36, 3.55
Chassis & Cab Salisbury type	4.44, 3.36, 3.55

A limited slip differential is available as an option on ~~all~~ ^{190mm AXLES} models.

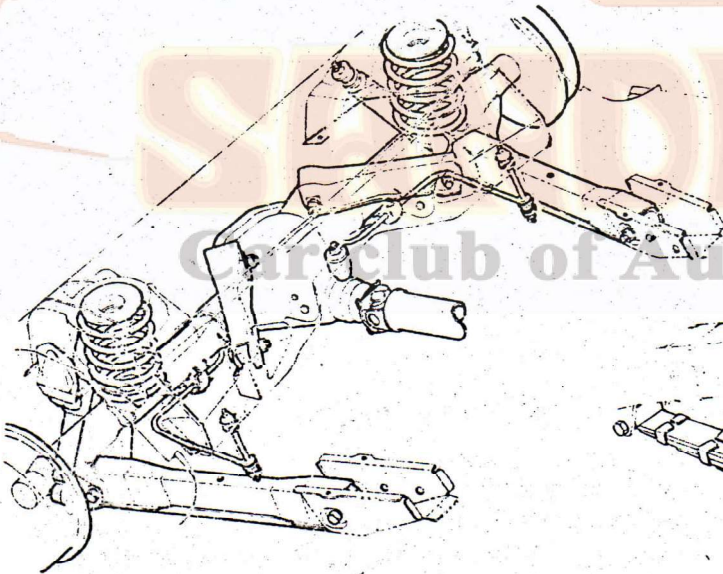

PASSENGER REAR AXLE & SUSPENSION
 (SALISBURY AXLE)

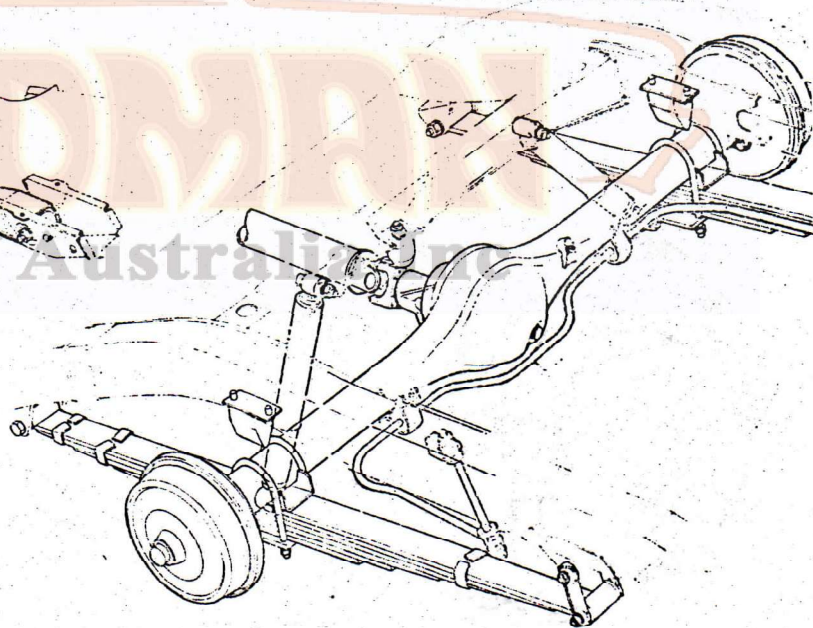

COMMERCIAL REAR AXLE & SUSPENSION
 (SALISBURY AXLE)

REAR SUSPENSION

The rear suspension as a factor in the ride and handling improvement objective has been re-developed for 'HZ'.

- * New rear axle lower control arm bushings are fitted to reduce road noise transmission, improve impact harshness and provide reduced compliance understeer.
- * Higher load and stiffer rear springs to improve ground clearance and ride with more progressive suspension bump through.
- * Increased diameter rear shock absorbers tuned to the new suspension giving reduced fade, improved road holding and ride comfort.
- * Improved shock absorber upper mountings improving road holding and durability while reducing noise transmittance.
- * Rear stabiliser bars are featured on the entire Holden model range giving benefits of less body roll and optimum roll couple distribution front to rear for improved handling. The stabiliser bar is a 'Decoupled type', the advantages of which are: Improved efficiency, minimum weight penalty, reduced compliance steer, impact harshness, and noise transmission.

Issued: MAY, 1977 Revised:

HOLDEN 'H2' FEATURES

MECHANICAL

B R A K E S

LEADING TRAIN

KINGSWOOD 'SL', PREMIER AND COMMERCIAL MODELS ARE FITTED WITH THE 11" (279 mm.) DISC FRONT BRAKES AND 10" ~~5/8" DRIVE~~ REAR DRUM BRAKES. 4 WHEEL DISC BRAKES, FOR IMPROVED FADE RESISTANCE ARE A STANDARD FEATURE ON ~~THE LOW-COST~~ STATESMAN MODELS ~~AND MONARO GTS.~~ THE REAR ANTI-LOCK BRAKING SYSTEM REMAINS OPTIONAL ON STATESMAN MODELS AND IS NOT AVAILABLE ON ANY OTHER MODEL. THESE PLUS THE FLOOR MOUNTED HANDBRAKE AND THE HANDBRAKE WARNING LAMP ARE ALL ITEMS WHICH CONTRIBUTE TO 'H2' SAFETY AND BRAKING EFFICIENCY.

FRONT DISC BRAKES

STANDARD EQUIPMENT ON ALL MODELS. THE POWER ASSISTED FRONT DISC BRAKES USE A LIGHTWEIGHT ALUMINIUM SINGLE PISTON SLIDING CALIPER. A ONE INCH THICK VENTILATED DISC PROVIDES A COOLING EFFECT DURING OPERATION WHICH ALLOWS EXTENDED PAD LIFE.

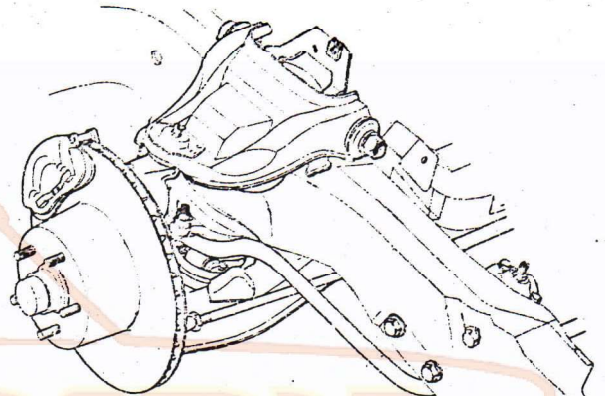
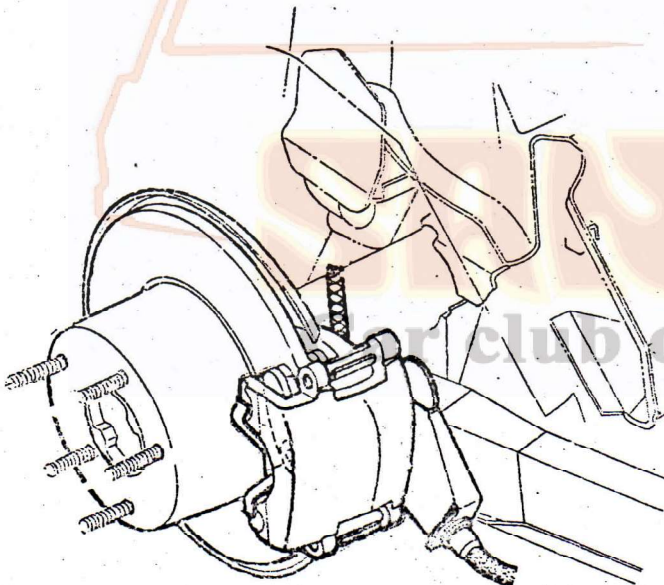

REAR DISC BRAKES

STANDARD ON STATESMAN ~~AND GTS~~ AND AVAILABLE AS AN OPTION ON ALL OTHER MODELS EXCEPT CHASSIS CAB. THE SOLID DISCS ARE MOUNTED ON THE REAR AXLE SHAFT FLANGE AND OPERATED BY SINGLE PISTON SLIDING HEAD CALIPERS MOUNTED ON THE AXLE HOUSING. THE CALIPERS INCORPORATE AN INTEGRAL SELF-ADJUSTING PARKING BRAKE FEATURING AN EFFICIENT BALL AND RAMP ACTUATING MECHANISM.

REAR ANTI-LOCK SYSTEM

TO PREVENT REAR WHEEL LOCK WHEN BRAKING A SMALL ELECTRONIC CONTROL DEVICE MEASURES DECELERATION AGAINST WHEEL SPEED AND AUTOMATICALLY APPLIES AND RELEASES THE REAR BRAKES BY MODULATING HYDRAULIC LINE PRESSURE TO THE REAR BRAKES.

PARKING BRAKE

THE CONVENIENT FOLD DOWN HANDBRAKE ALLOWING EASE OF ACCESS TO AND EXIT FROM THE VEHICLE IS RETAINED FOR ~~H2~~. THE LEVER IS FLOOR MOUNTED ON THE RIGHT SIDE OF THE FRONT SEAT, AND OPERATES THE REAR BRAKES THROUGH A SYSTEM OF CABLES. A HANDBRAKE WARNING LAMP WHICH OPERATES WHEN THE BRAKES ARE ENGAGED AND A SEPARATE HYDRAULIC BRAKE CIRCUIT FAILURE WARNING LAMP ARE RETAINED FOR 'H2'. STATESMAN CAPRICE FEATURES A VINYL COVER OVER THE HANDBRAKE LEVER.

Issued: MAY, 1977

Revised:

HOLDEN 'HZ' FEATURES

MECHANICAL

ENGINES

THE ENGINE AVAILABILITY FOR 'HZ' CONSISTS OF TWO ENTIRELY SEPARATE ENGINE LINE-UPS: A DOMESTIC RANGE COMPRISING OF 3,3 L6 4,2 AND 5,0 V8's AND AN EXPORT RANGE OF 2,8 & 3,3 L6 4,2 & 5,0 V8's.

LOCAL ENGINES COMPLY WITH 1976 EMISSION CONTROL STANDARDS.

ENGINES PROVIDED FOR EXPORT AND INDUSTRIAL APPLICATIONS WHERE AUSTRALIAN DESIGN STANDARDS FOR EMISSION CONTROL ARE NOT REQUIRED ARE MANUFACTURED TO UNCHANGED 'HJ' FORM.

SANDMAN
Car club of Australia Inc

'HZ' BASE DOMESTIC ENGINE RANGE

ENGINE	BORE & STROKE ins. / mm.	COMP. RATIO :1	TORQUE		GROSS OUTPUT		MODEL
			LBFT	RPM Nm	HP	RPM kW	

6 CYLINDER

3,3 MANUAL		9.2	185	1400 251	3900 109	81	HOLDEN COMMERCIAL KINGSWOOD 'SL'
---------------	--	-----	-----	-------------	-------------	----	-------------------------------------

8 CYLINDER

4,2	3.625 x 3.062 92.0 x 77.7	9.4	240	2600 325	4550 161	120	PREMIER
5,0	4.000 x 3.062 101.6 x 77.7		295	3100 400	4800 216	161	GTS & STATESMAN

Issued: MAY, 1977 Revised: JULY, 1978

HOLDEN 'HX' FEATURES

MECHANICAL

TRANSMISSION

THERE ARE SIX TRANSMISSIONS USED IN THE *WB* RANGE:

ONE 3-SPEED, ALL SYNCHROMESH MANUAL TRANSMISSION.

THREE ALL SYNCHROMESH, 4-SPEED MANUAL TRANSMISSIONS.

TWO 3-SPEED AUTOMATIC TRANSMISSIONS (TRIMATIC AND TURBO-HYDRAMATIC *400* *350*)

ALL TRANSMISSIONS ACCEPT AND OPERATE THE EMISSION CONTROL TRANSMISSION CONTROLLED SWITCH (TCS)

THIS SWITCH IS ACTIVATED WHEN THE TRANSMISSION ENTERS TOP GEAR.

THE NOISE ISOLATION ADVANTAGES OF A CABLE OPERATED CLUTCH CONTROL MECHANISM FOR ALL MANUAL TRANSMISSION EQUIPPED VEHICLES IS RETAINED.

'HX' TRANSMISSION LINE-UP

PRODUCTION OPTION Nos.	TRANSMISSION	RATIO : 1 FIRST GEAR	■ AVAILABILITY
M15	3 SPEED ALL SYNCHRO MANUAL.	3.07	L6 AND 4,2 V8
M20	4 SPEED ALL SYNCHRO MANUAL. FLOOR SHIFT	3.05	
M21		2.54	4,2 AND 5,0 V8
M22		3.74	L6
M40	3 SPEED AUTOMATIC (TRIMATIC)	-	L6 AND 4,2 V8
<i>238</i>	3 SPEED AUTOMATIC (TURBO-HYDRAMATIC <i>400</i> <i>350</i>)	-	5,0 V8

Car club of Australia Inc

3 SPEED ALL SYNCHROMESH

THE BASE MANUAL TRANSMISSION FOR KINGSWOOD AND HOLDEN COMMERCIALS IS THE 3 SPEED COLUMNSHIFT, ALL SYNCHROMESH UNIT.

4 SPEED ALL SYNCHROMESH

THE 4 SPEED MANUAL TRANSMISSION HAS SYNCHROMESH ON ALL FORWARD GEARS, WITH A FLOORSHIFT CONTROL LEVER. TO SUIT ENGINE OR VEHICLE LOAD REQUIREMENTS, THREE VERSIONS OF THIS TRANSMISSION ARE AVAILABLE (SEE CHART ABOVE). PREMIER SEDANS CAN BE FITTED WITH M20 OR M21 TRANSMISSIONS AS OPTIONAL EQUIPMENT.

'TRIMATIC' AUTOMATIC TRANSMISSION

3 SPEED AUTOMATIC 'TRIMATIC' TRANSMISSION OPERATES WITH THE LOW VACUUM SIGNAL OF EMISSION EQUIPPED ENGINES. THE FEATURE OF "FULLY COUNTERPHASED GEARSET" DESIGN IS RETAINED TO ENSURE LOW GEAR AND TRANSMISSION NOISE. AN ELECTRICALLY OPERATED DETENT DOWNSHIFT IS USED. THE TRIMATIC TRANSMISSION IS FITTED AS STANDARD ON PREMIER AND IS AVAILABLE WITH 3,3 AND 4,2 ENGINES AS AN OPTION.

TURBO-HYDRAMATIC 400

TO CATER FOR THE HIGH POWER OUTPUT OF THE 5.0 ENGINE, A 3 SPEED AUTOMATIC TRANSMISSION KNOWN AS TURBO-HYDRAMATIC ~~400~~ IS FITTED. THIS TRANSMISSION IS OF HEAVY DUTY CONSTRUCTION FOR SMOOTH OPERATION AND DURABILITY. A MAJOR FEATURE IS A LOCK UP TORQUE CONVERTER, THIS UNIT LOCKS AT A PREDETERMINED LOAD & SPEED ELIMINATING SLIPPAGE AND AIDING IN REDUCING FUEL CONSUMPTION.

Issued: MAY, 1977 ■ Revised: AUGUST, 1977

HOLDEN 'H2' FEATURES

MECHANICAL

FUEL TANK

THE ^{WB} ~~'H1'~~ PASSENGER VEHICLE FUEL TANK USES A ^{NEW} CARRY OVER SHAPE GIVING A FUEL CAPACITY OF ~~15.5 GALLONS~~ (75 LITRES). THE TANK IS LOCATED BY STRAPS UNDER THE REAR COMPARTMENT FLOOR, WITH THE FUEL LINES AND FILLER ^{ON STATESMAN AIR FILLER IS LOCATED ON THE REAR SIDE OF THE CAB} OUTSIDE THE BODY. THE CHASSIS CAB, PANEL VAN AND UTILITY TANK IS CARRIED OVER FROM 'H1'. THE TANK IS MOUNTED WITHIN THE CHASSIS FRAME AT THE REAR OF THE CAB. ALL COMMERCIALS USE THE SAME TANK, THE FILL PIPE VENT SYSTEM BEING DIFFERENT ON THE CHASSIS CAB. THE COMMERCIAL TANK CAPACITY IS 15.5 GALLONS (70 LITRES). THE FUEL FILLER CAP FOR ^{HOLDEN} ~~SEBAM~~ MODELS IS CONCEALED BEHIND THE HINGED REAR LICENCE PLATE ^{WHILE O} FOR STATION WAGONS IT IS LOCATED ON THE RIGHT HAND LOWER REAR QUARTER ADJACENT TO THE REAR WHEEL ARCH. ON COMMERCIAL VEHICLES THE FUEL FILLER IS LOCATED ON THE RIGHT HAND SIDE ABOVE THE BODY WIDE LINE TO THE REAR OF THE DRIVERS DOOR. THE FUEL TANK CAP IS FITTED WITH A SPECIAL VALVE TO FORM PART OF THE EVAPORATIVE EMISSIONS SYSTEM. THIS CAP MUST NEVER BE REPLACED BY A NON STANDARD PART. ^{ON STATESMAN THIS CAP}

STATSMAN &

A LOCKABLE CAP IS LOCATED BEHIND A COVER FLAP.

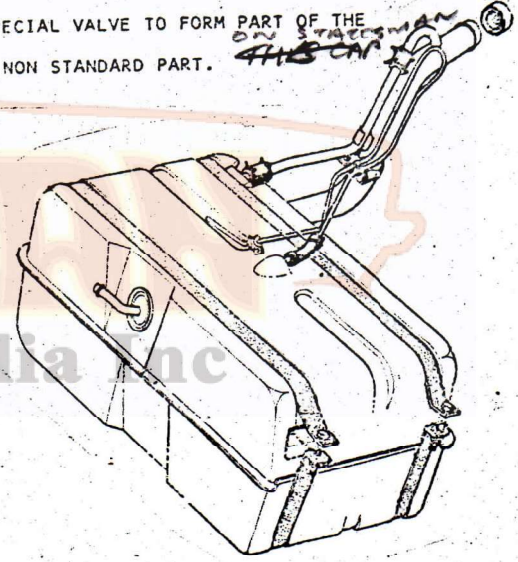
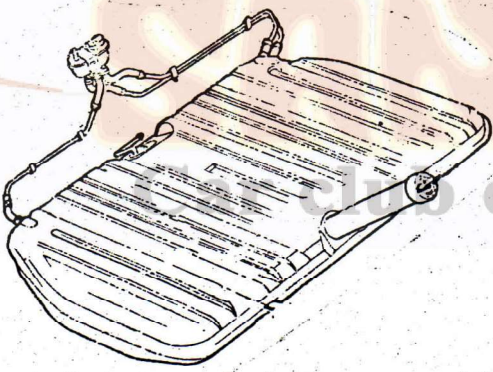

KEYS & LOCKS

A ^{USED} ~~NEW~~ 2 KEY LOCKING SYSTEM IS ^{ALLOWING} ~~INTRODUCED TO ALLOW~~ A SECURITY FACILITY FOR PERSONAL VALUABLES WHEN LEAVING VEHICLE IN CAR PARK AREAS.

A MASTER KEY RETAINED BY THE DRIVER OPERATES ALL LOCKS ON THE VEHICLE WHILE A SERVICE KEY THAT WILL OPERATE IGNITION AND DOOR LOCKS BUT NOT LUGGAGE AND INSTRUMENT PANEL COMPARTMENT REMAINS WITH THE CAR.

THE ANTI-THEFT FEATURE OF THE COMBINED IGNITION SWITCH AND STEERING LOCK IS CARRIED OVER WITH THE SWITCH BEING MOUNTED IN THE UPPER RIGHT HAND SECTION OF THE STEERING COLUMN BELOW THE STEERING WHEEL.

MASTER KEY

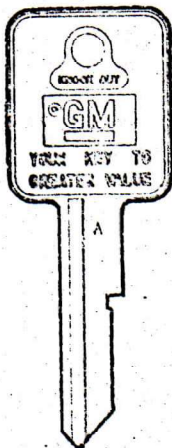

SERVICE KEY

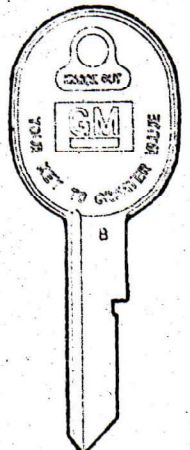

Issued: MAY, 1977

Revised:

HOLDEN 'HZ' FEATURES

MECHANICAL

STEERING

REAR MOUNTED PARALLEL CONTROL
 The Steering System is improved on 'HB' to increase driver control and road feel. *WB* The 20.7:1 ratio is discontinued and the 25.0:1 ratio is standard on all manual steering cars including *WB* ~~the~~ Statesman.

Stiffer connecting rod insulators *CONTROL* reduce compliance in the steering linkage to improve response, road feel and *retain good* steering impact.

THE A new steering column to dash cover attachment *eliminates most* decreases vertical vibration on gravel or rough bitumen roads *WB* prevents severe shaking during braking on corrugations and broken surfaces and takes the compliance out of the steering system to improve response and predictability.

WB The power steering pump and gear are also revised for improved steering feel and reduced effort while parking.

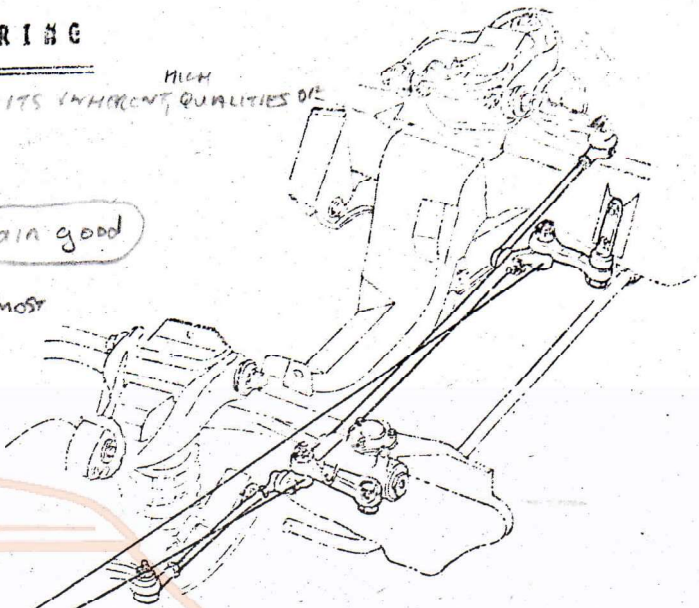

HZ
CONNECTING ROD
INSULATOR

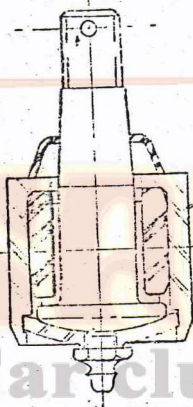

MANUAL STEERING

A Manual Steering Gear is standard on all models except Statesman. The front mounted steering linkage introduced in 'HQ' series for its inherent handling and safety characteristics is carried over into all 'HZ' models. The overall steering ratio for all models is 25.0:1.

Carclub of Australia Inc

VARIABLE RATIO POWER STEERING GEAR

WB Variable Ratio Power Steering Gear is carried over into 'HB' and is standard equipment on all Statesman models. *WB* Improvements have been made to the power steering by increasing the pump pressure, increasing the torsion bar diameter, revising the valve calibration by altering the slot width and fitting a needle roller bearing to the sector shaft.

POWER STEERING SYSTEM ALLOWS REDUCED
 These modifications have improved steering effort during parking with brakes on, improved on-centre feel and improved dynamic effort to provide a high degree of vehicle feel comparable to top European cars. These revisions have also improved the durability of the gear.

WITH The power steering maintains a pleasant steering feel throughout all steering conditions. Compared to a manual steering car a reduction in the number of turns lock to lock is achieved without affecting driver effort adversely. Power steering is 2.6 turns lock to lock while the manual has 5.2 turns. *NOTICABLE*

The steering gear is a full integral unit with all control mechanism and assist piston inbuilt. The variable ratio gives an overall ratio of 18.1:1 on centre varying to 11.4:1 at full lock. This gives a faster ratio the further the wheel is turned to give a light effort for parking while still allowing driver 'feel' during normal operating conditions.

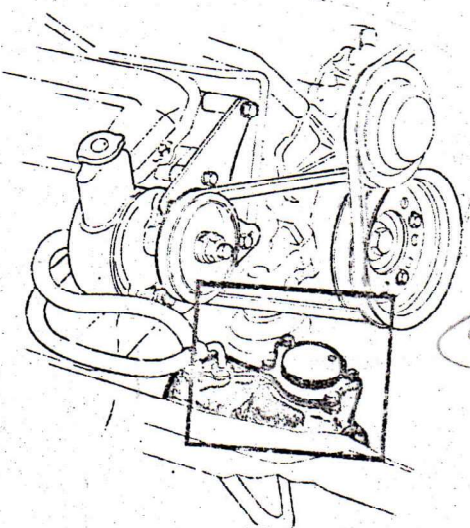

Issued:

MAY, 1977

Revised:

HOLDEN 'HZ' FEATURES

MECHANICAL

WHEELS & TYRES

~~TO OBTAIN MAXIMUM RIDE AND HANDLING BENEFITS NEW WHEELS AND TYRES ARE FITTED TO THE HZ.~~

6.00JJ WHEELS ARE STANDARD ON ALL VEHICLES WITH THE WHEEL OFFSET INCREASED TO GIVE THE WIDE TRACK PREVIOUSLY AVAILABLE ONLY WITH GTS RALLY WHEELS.

RADIAL PLY TYRES ~~AS~~ STANDARD ON ALL VEHICLES, STEEL BELTED ON ALL BASE PASSENGER MODELS AND CHASSIS CAB. TEXTILE RADIALS ON KINGSWOOD (A9K), PANEL VAN AND UTILITY.

~~THESE MODIFICATIONS RESULT IN IMPROVED HANDLING THRU HIGHER LATERAL TYRE STIFFNESS WHILE THE HIGHER COST OF THESE TYRES IS MORE THAN OFFSET BY THE INCREASE IN TYRE MILEAGE AND IMPROVED FUEL ECONOMY OBTAINABLE.~~

CAPRICE WHEELS

SIZE	MODEL	OPTION
6.00"JJ X 14	ALL MODELS EXCEPT GTS & CHASSIS CAB	-
6.00"JJ X 14 (RALLY WHEEL)	MOUNTED GTS	ALL MODELS EXCEPT STATESMAN CAPRICE AND CHASSIS CAB
6.00"JJ X 14	CHASSIS CAB	-

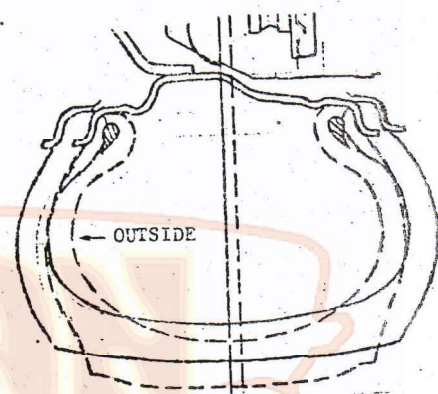

NEW WHEEL OFFSET
Dotted Line HX, Solid Line HZ

6.00JJX14 WIRE SPOKE
6.00JJX14 FAMILYCASTALLOY
7.00JJX15 FAMILYCASTALLOY

PREMIER & DEVILLE
ALL MODELS EXCEPT CAPRICE AND CHASSIS CAB

BASE TYRE RANGE

SIZE	TYRE CONSTRUCTION		LOAD RATING	MODEL	
	TYRE	CORD MATERIAL			
185SR14	RADIAL	TEXTILE	4 P/R	10 cwt. DERATED PANEL VAN & UTILITY 500 kg.	
195SR14				MAX. RATED PANEL VAN & UTILITY KINGSWOOD (A9K) & STATESMAN DEVILLE	
195R14LT		STEEL	8 P/R	CHASSIS CAB	
ER78S14				4 P/R	STATION WAGONS, SHORT WHEEL BASE SEDANS
ER70H14				6 P/R	MOUNTED GTS AND 10 cwt. DERATED SANDMAN 500 kg.
FR78S14				4 P/R	STATSMAN, MAX. RATED SANDMAN
ER60H15		4 P/R	STATSMAN CAPRICE		

WALL COLOURS - BLACKWALL - ALL EXCEPT STATESMAN CAPRICE, STATESMAN DEVILLE.
SINGLE WHITE BAND - OPTIONAL STATESMAN AND PREMIER.

SPARE WHEEL MOUNTINGS

- VERTICALLY MOUNTED ON LHS SIDE OF LUGGAGE COMPARTMENT
- ALL SEDANS (EXCEPT STATESMAN) - HORIZONTALLY MOUNTED ON LUGGAGE COMPARTMENT FLOOR. COVER - HARDBOARD.
 - STATSMAN DEVILLE & CAPRICE - DELIQUELY MOUNTED ON FORWARD SECTION OF LUGGAGE COMPARTMENT. COVER: - DEVILLE - VINYL, CAPRICE - CARPET.
 - STATION SEDANS - HORIZONTALLY MOUNTED BELOW LOAD COMPARTMENT FLOOR.
 - COMMERCIALS - HORIZONTALLY MOUNTED TO THE FRAME ON A DROP CRADLE.

Issued: MAY, 1977 Revised: JUNE, 1977

HOLDEN 'HZ' FEATURES

MECHANICAL

EXTERNAL LAMPS

ALL VEHICLES ARE FITTED WITH HEAD, PARKING, STOP/TAIL, AMBER TURN SIGNAL/BACK-UP, AND REAR LICENCE PLATE LAMPS. SIDE MARKER LAMPS ARE USED ON SOME MODELS. LAMP LOCATIONS ARE SHOWN ON VEHICLE ILLUSTRATIONS IN GROUP 'B'.

HEAD LAMPS

HOLDEN PASSENGER AND *DUAL 5 1/2" 146*
THE HEADLAMPS ON ~~KINGSWOOD AND HOLDEN~~ COMMERCIALS ARE ~~SINGLE 7 1/2" (178 MM)~~ SEALED BEAMS. ~~ADDITIONALLY THE CHASSIS CAB HAS INTEGRAL HEAD AND PARK LAMPS. QUARTZ HALOGEN SEMI-SEALED BEAMS ARE FEATURED ON KINGSWOOD SL. PREMIER, GTS, SANDMAN AND STATESMAN HAVE DUAL 5 1/2" (146 MM) SEALED BEAM QUARTZ HALOGEN LAMPS WITH GTS AND SANDMAN HAVING HI-POWER HI-BEAM LAMPS.~~

STATESMAN MODELS ARE FITTED WITH TRAPEZOIDAL QUARTZ HALOGEN LAMPS.

FRONT TURN SIGNAL AND PARKING LAMP

FRONT TURN SIGNAL & PARKING LAMP CONSISTS OF
THE 'HZ' MODEL (EXCEPT CHASSIS CAB) RETAINS A RECTANGULAR WRAP AROUND LAMP ASSEMBLY MOUNTED VERTICALLY IN THE UPPER LEADING EDGE OF THE FRONT FENDERS. THE LAMP HAS AN OUTER CLEAR LENS WITH THE PARKING LAMP MOUNTED IN THE UPPER SECTION. THE LOWER SECTION HAS AN INNER AMBER LENS FOR THE TURN SIGNAL LAMPS. THE POSITION OF THE LAMPS AFFORDS AN EXCELLENT FIELD OF VISIBILITY TO OTHER TRAFFIC. ~~THE CHASSIS CAB IS FITTED WITH HEAD LAMP MOUNTED PARK LAMPS AND CIRCULAR PROJECTING AMBER TURN SIGNAL LAMPS INBOARD OF THE HEADLAMPS.~~

REAR LAMPS

THE REAR LAMPS ON ALL SEDAN MODELS ARE ALSO OF THE WRAP AROUND TYPE AND ARE DIVIDED INTO TWO SECTIONS. THE UPPER SECTION CONSISTS OF RED STOP/TAIL LAMPS, THE LOWER BEING AMBER TURN SIGNAL/BACK-UP LAMPS.

STATION SEDAN, PANEL VAN AND UTILITY HAVE VERTICALLY MOUNTED LAMPS WITH THE UPPER SECTION BEING STOP/TAILED AND THE LOWER BEING TURN SIGNAL/BACK-UP.

THE CHASSIS CAB HAS INDIVIDUAL STOP/TAIL, TURN SIGNAL/BACK-UP LAMPS BOLTED TO THE CHASSIS FRAME.

RECTANGULAR SIDE MARKERS CONTAINING A TURN SIGNAL REPEATER LAMP AND A RED REFLECTOR ARE ONLY FITTED TO STATION SEDAN, PANEL VAN AND UTILITY MODELS.

THE REAR NUMBER PLATE POSITION IS ILLUMINATED BY AN INDEPENDENT BULB.

Issued: MAY, 1977

Revised:

HOLDEN 'HIZ' FEATURES

MECHANICAL

INTERNAL LAMPS

POSITION AND OPERATION		MODEL
DOME	Light switch controlled	All Sedans and Commercials
	Front door switch controlled	All except Holden Commercials
	Rear door switch controlled	Statesman and Premier (Statesman Caprice & Calais lamps incorporate 2 map lamps)
REAR QUARTER LAMP	Activated by light switch and all door switches	Statesman DeVille
FOOTWELL ILLUMINATION		Statesman Caprice, DeVille, Premier & GTS sedan
REAR COMPARTMENT READING LAMP	Light, door and independent combined switch activated	Statesman Caprice
FRONT AND REAR DOOR COURTESY AND WARNING LAMP (RED & WHITE LENS ON LOWER INNER DOOR TRIM). All door and light switch activated.		Statesman Caprice & Calais
GLOVE COMPARTMENT LAMP		Statesman, Premier and Monaro 'GTS'
LUGGAGE COMPARTMENT LAMP		

INSTRUMENT PANEL AND TELL-TALE LAMPS

All instruments, auto shift indicators and windscreen wiper switch - indirect blue lighting.
Non functioning tell tales show black faces.

LAMP	POSITION	MODEL
HI-BEAM LH TURN SIGNAL RH TURN SIGNAL PARK BRAKE BRAKE FAILURE GENERATOR OIL PRESSURE FUEL ECONOMY (optional)	- Blue - Green arrow - Green arrow - Red - Red - Red - Red - Orange	Centre warning lamp panel HI beam small rectangle all others large rectangles with corresponding symbol.
TEMPERATURE	- Red	LH instrument lwr warning lamp
OIL PRESSURE BATTERY	- Red - Red	Fuel and Temperature Gauge panel
LH TURN SIGNAL	- Green arrow	Tachometer
		Clock
		Digital Clock
RH TURN SIGNAL	- Green arrow	Speedometer
HEATED WINDOW SWITCH	- Orange	Lamp in switch
PARK BRAKE BRAKE FAILURE HI-BEAM	- Red - Red - Blue	Individual Centre Rectangles
ASH TRAY AND CIGAR LIGHTER		Instrument panel
PARK BRAKE BRAKE FAILURE HI-BEAM	- Red - Red - Blue	Individual Centre Rectangles Speedometer

HZ INSTRUMENT PANELS FEATURE ISO STANDARD SYMBOLS TO IDENTIFY INSTRUMENTS & CONTROLS.
THE NEEDLES AND DIVISIONS ON GAUGES ARE COLOURED BRIGHT YELLOW AGAINST BLACK TO IMPROVE VISIBILITY.

Issued: MAY, 1977

Revised:

HOLDEN '11Z' FEATURES

MECHANICAL

EMISSION CONTROLS

GENERAL

Emission Control is now an important feature of automotive design. Control devices are designed to reduce the output of gases that are harmful to man and the environment.

The systems fitted to Holden vehicles can be divided into sub-groups. Each system operates and can be (and has been) introduced progressively to form an overall integrated system.

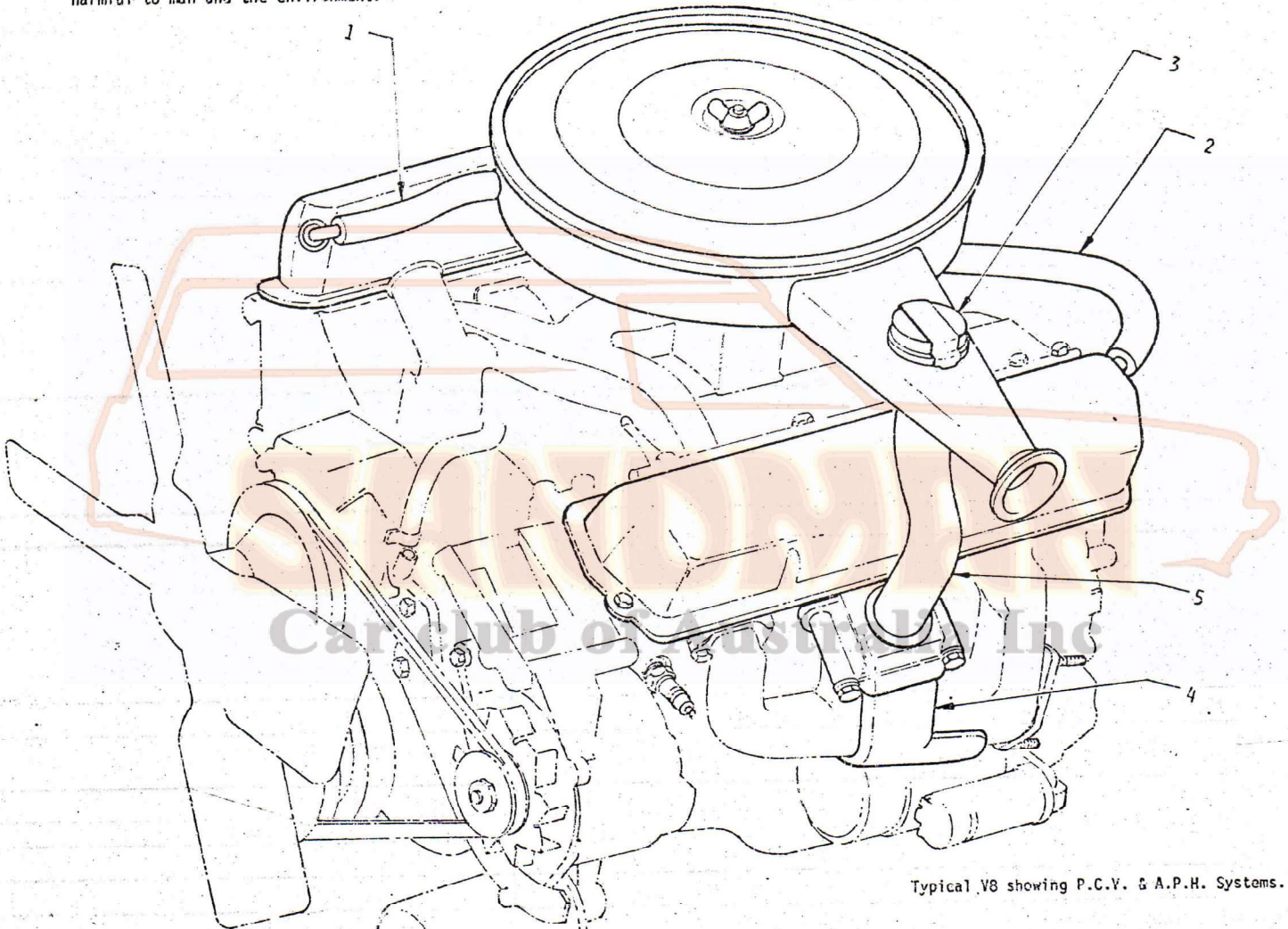

Typical V8 showing P.C.V. & A.P.H. Systems.

POSITIVE CRANKCASE VENTILATION P.C.V. (1&2)

This system is designed to reduce hydrocarbon emissions. Clean air enters the engine crankcase through a hose (1) from the outer rim of the air cleaner to the rocker cover and flows through the engine mixing with the blow by gases. The mixture is then drawn out through a valve (2) into the inlet manifold to be burnt in the combustion chamber.

CONTROLLED COMBUSTION SYSTEM - C.C.S.

This is not an add on system, but a refinement of the necessary engine functions. Attention is paid to distributor and carburettor settings and tolerances to achieve a close control of engine operation.

EVAPORATIVE EMISSION CONTROL SYSTEM - E.C.S.

This system further reduced hydrocarbon losses. It is designed to reduce the escape of fuel vapour to the atmosphere. The fuel tank and carburettor are vented to an activated carbon canister. At rest

all vapours given off by the fuel are fed to the carbon canister to be stored. During engine operation the canister is purged of fuel vapours which are drawn into the inlet manifold to be burnt in the combustion chamber.

CARBURETTOR AIR PREHEAT - A.P.H.

This allows significantly leaner carburettor calibration for reduced emissions. Carburettor air is heated to approximately 40°C when underhood temperatures are low. A damper door (3) controlled by engine vacuum and a bi-metallic thermostat regulates heated air from an exhaust manifold heat stove (4 & 5). This also improves engine driveability during warm-up allowing reduced choke operation time.

Issued: MAY, 1977

Revised: OCTOBER, 1976

HOLDEN 'HZ' FEATURES

MECHANICAL

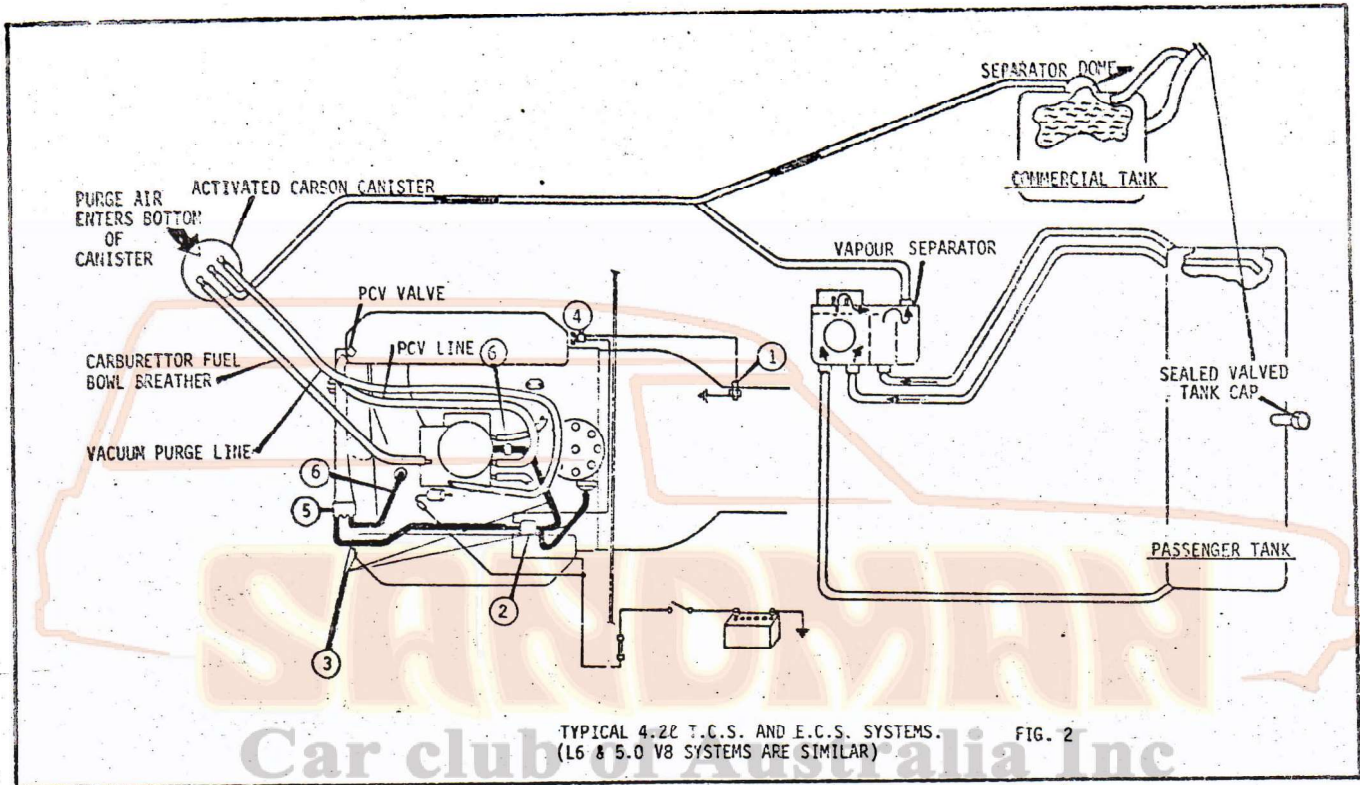

TYPICAL 4.2L T.C.S. AND E.C.S. SYSTEMS. (L6 & 5.0 V8 SYSTEMS ARE SIMILAR) FIG. 2

Additional Emission Control Systems to meet ADR 27A are applicable from July 1, 1976 vehicle production.

These controls call for a further reduction in Emission levels to achieve an overall reduction of 80% of the Hydrocarbons HC (15% less than before ADR 27A) and 69% of Carbon Monoxide CO (13% Decrease).

Control of Nitrogen Oxide NOx levels is introduced for the first time and a reduction of approx. 38% has been obtained.

In achieving this level of control significant changes have been made to the engines as well as the addition of a considerable number of peripheral devices.

Fitment of these Emission Controls results in a lowering of performance and Economy levels.

Three basic areas are affected :-

- (1) The provision of a fuel mixture of a quality which will minimise the formation of HC and CO.
This is achieved by revision to the carburettor and provision of an exhaust heated manifold. Refer section A&B for details.
- (2) Control of spark timing.
Retarding the spark reduces the formation of HC and NOx but has a bad effect on fuel economy, cooling and performance.
A range of devices are fitted to retard the spark when necessary for Emission Control, but to allow advance when possible to gain fuel economy, cooling and performance advantages. Refer Section D

- (3) Exhaust Gas Recirculation
This is a system allowing exhaust gases to feed back into the combustion chamber providing a reduction in formation of NOx. Ref. Section C.

A revision is made to the EGS carbon canister deleting the ported signal valve and connecting the purge line directly to the carburettor via an internal signal port.

(A) EXHAUST GAS CROSS-OVER AND HEAT VALVE.

The critical phase of Emission Control is during the warm-up period. Approx 30% of the ADR limit of HC and CO are delivered during the first two minutes.

Control is achieved by diverting exhaust gas against the floor of the inlet manifold under the carburettor risers, by blocking the exhaust manifold with a bi-metallic spring controlled valve. After the warm-up period the valve opens to avoid overheating the fuel mixture leading to economy and power losses and to prevent manifold warping.

(B) CARBURETTOR MODIFICATIONS

L6:- The carburettor is completely redesigned being shorter in height with a push type accelerator pump. The choke butterfly is now at 90° to the throttle shaft and the fuel bowl vent is repositioned. The main body has connections for vacuum advance, and canister purge. The throttle body is made of aluminium and has connections for E.G.R. and air preheat. The air cleaner attachment is similar to the 4.2 V8.

V8:- V8 carburettors change less than L6. The changes are:

Heat Pickup for Auto Choke.

HOLDEN 'HZ' FEATURES

MECHANICAL

E.G.R. Signal Connection

Air Preheat Connection

Quadrajet Carburettors have a new integral choke mechanism.

ALL CARBURETTORS:- Common features are:

- Insulator Heat Shield between carburettor and manifold.
- Anti Dieseling Solenoid.

Higher engine speeds are required to obtain good idle quality with the lean mixtures required for emission control. The combination of these factors and hot weather can allow the engine to run on (or diesel) when the ignition is switched off. This is harmful to the engine. The anti-dieseling solenoid is activated by the ignition switch and acts as an idle stop. When the ignition switch is turned off the solenoid is de-energised allowing the throttle valve to close fully, thereby starving the engine of fuel and air to positively prevent dieseling.

Starting an engine requires the ignition being switched on and the throttle opened approx. 1/4, allowing the solenoid to set and fuel and air to pass thru the carburettor.

(C) EXHAUST GAS RECIRCULATION (EGR)

(FIG. 4)

Nitrogen oxides are mainly generated at high combustion temperatures, particularly during lugging periods in low gear or high speed road load conditions. By introducing inert exhaust gas into the intake mixture the combustion process is retarded, the combustion temperatures are lowered and Nitrogen Oxide emissions are reduced.

The components required for EGR are:

1. EGR Valve
2. Vacuum signal line from carburettor to actuate the valve incorporating thermal vacuum switch V8 only.
3. Passages in the inlet manifold to duct exhaust gas.

The E.G.R. system operates at all times on L6 engines. The V8 system remains activated when the coolant exceeds 35°C. The control is a thermal vacuum switch in the vacuum signal line. When cold with full choke and over rich mixture, the inefficient burning causes low temperature in the combustion chamber, hence low NOx emissions. After 35°C the EGR operates depending on the vacuum signal. The signal line is above the throttle butterfly and at idle there is no signal. To obtain best engine performance when the throttle is wide open the valve does not operate due to the inlet depression being zero.

At throttle openings in between idle and full throttle the vacuum signal operates the EGR valve. Exhaust gas feeds from the cross-over passages into the inlet manifold below the carburettor to be evenly distributed to all cylinders.

DISTRIBUTOR MODIFICATIONS

Distributor advance is separated into centrifugal, designed to give maximum power on wide open throttle, and vacuum giving best economy on part throttle. But as explained previously emission control conflicts with optimum distributor operation for performance and economy.

After-burning in the exhaust manifold is relied upon to reduce unburnt HC and NOx. Increasing the temperature in the exhaust manifold to obtain this after-burning is achieved by retarding the spark. The retarded spark also lowers combustion temperatures and thereby reduces NOx emissions.

The spark retard produces curb idle cooling problems and to overcome this the spark advance curve is a compromise between Emission Control and Performance, Economy and Cooling.

(D) TRANSMISSION CONTROLLED SPARK T.C.S.

The T.C.S. system is fitted to allow vacuum advance in top gear but to deny vacuum advance in the intermediate gears.

The basic components are (Fig. 2)

- T.C.S. Switch (1)
- T.C.S. Solenoid Valve (2)
- Hose Connections (3)

Secondary components are

- Cold Feed Switch (4)
- Thermal Vacuum Distributor Switch (5)
- Vacuum Delay Switch (6)

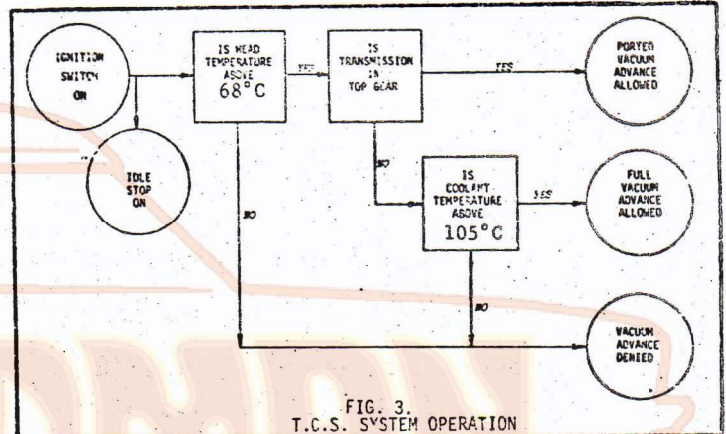

FIG. 3.
T.C.S. SYSTEM OPERATION

The T.C.S. system operates after engine temperatures stabilize.

Emissions of HC and CO run at a higher level on a cold engine than on a stabilised engine. To control this a cold feed switch (4) is installed in the cylinder head metal. This switch prevents vacuum advance at all times until the metal reaches 68°C and the switch closes allowing the T.C.S. circuit to function.

The transmission going into top gear closes the T.C.S. switch (1) and activates the T.C.S. solenoid valve (2) allowing the distributor to have ported vacuum signal after a time delay of approximately 30 seconds - (controlled by vacuum delay valve (6)). At all other times the vacuum advance diaphragm is vented thru the centre port of the distributor thermal vacuum switch (5)

With T.C.S. vacuum advance is not available at idle speeds, however, at high ambient temperatures it is necessary to introduce advance to maintain adequate cooling. Accordingly the thermal vacuum switch allows full manifold vacuum to the distributor when the coolant exceeds 105°C.

Issued: MAY, 1977

Revised: JUNE, 1977

HOLDEN 'HIZ' FEATURES

MECHANICAL

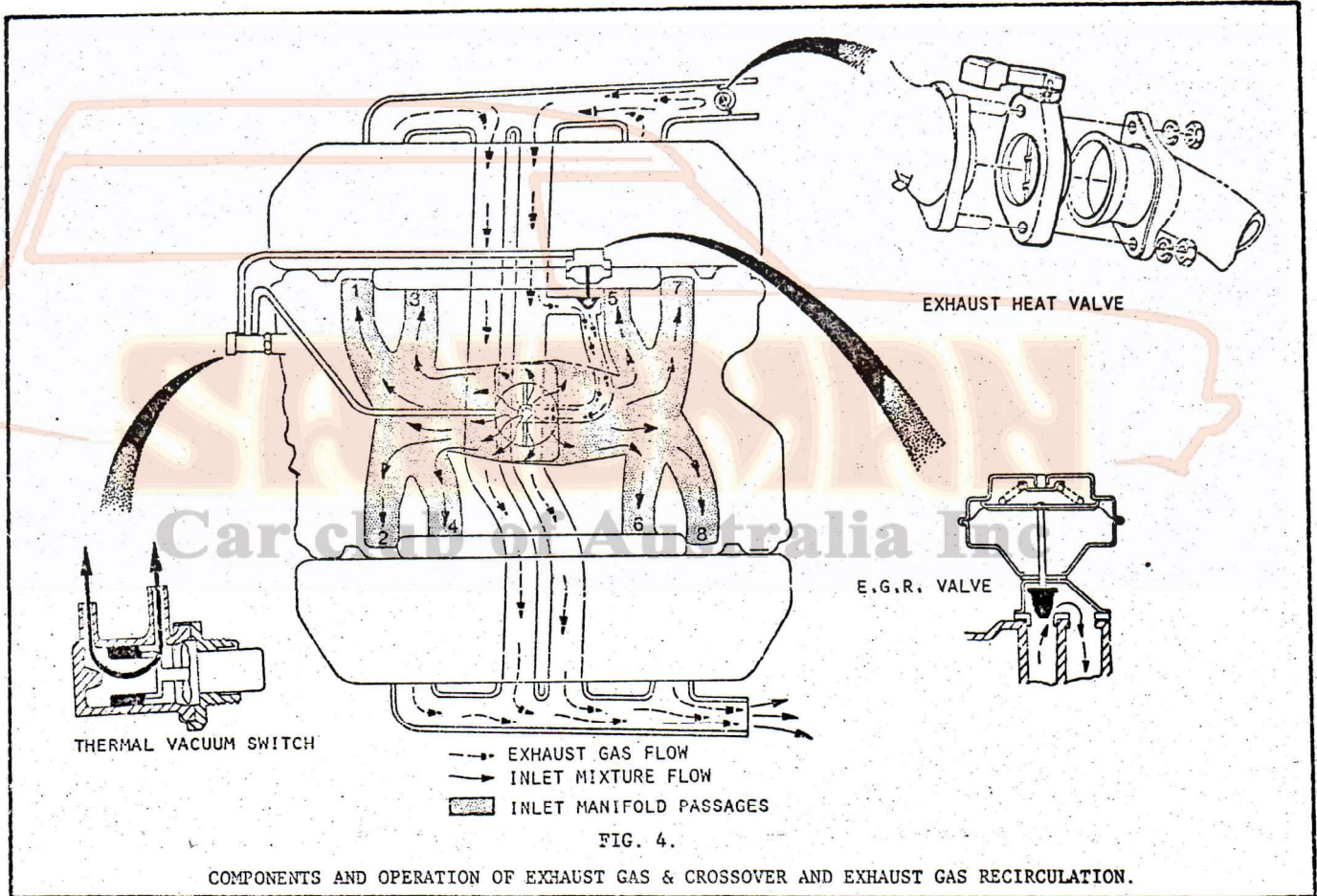

Issued:

MAY, 1977

Revised:

HOLDEN 'HZ' FEATURES

SPECIFICATIONS

INDEX TO SECTION F

BODY DIMENSIONS EXTERIOR	F-1, F-2
BODY DIMENSIONS INTERIOR	F-3 TO F-5
GLASS AREAS	F-11
SERIAL NUMBERS AND LOCATIONS	F-12 TO F-13
VEHICLE WEIGHTS	F-14 TO F-16
FRONT SUSPENSION	F-17 TO F-19
REAR AXLE AND REAR SUSPENSION	F-20 TO F-22
PROPELLOR SHAFT	F-23
BRAKES	F-24
ENGINE DATA	F-25 TO F-36
CLUTCH AND TRANSMISSION	F-37
AUTO TRANSMISSION	F-38
EXHAUST AND FUEL TANK	F-39
STEERING	F-40
WHEELS AND TYRES	F-41
ELECTRICAL	F-42

Issued: MAY, 1977

Revised:

INDEX

HOLDEN 'HZ' FEATURES

SPECIFICATIONS

BODY DIMENSIONS - EXTERIOR - INS.
- mm.

		SEDAN					STATION WAGON			COMMERCIAL							
		KINGSWOOD		PREMIER	GTS	DEVILLE	KINGSWOOD		PREMIER	PANEL VAN		UTILITY		CAB CHASSIS			
		P/O	SL				P/O	SL		K/ROOF	HOLDEN	K/WOOD	HOLDEN				
W101	TREAD - FRONT	60.1 1526			60.0 1524	60.5 1537			60.1 1526				59.9 1521 60.2 1529				
W102	TREAD - REAR												73.9 1877				
W103	VEHICLE WIDTH	73.9 1877	74.5 1892	73.9 1877	74.5 1892	73.9 1877	74.5 1892	73.9 1877	74.5 1892	73.9 1877	74.5 1892	73.9 1877					
W116	BODY WIDTH - MAXIMUM												73.9 1877				
W117	BODY WIDTH AT Sg RP - FRONT												73.2 1859				
W106	FRONT FENDER WIDTH												73.7 1872				
W107	REAR FENDER WIDTH	73.6 1869						73.5 1876						N/A			
W120	VEHICLE WIDTH - FRONT DOORS OPEN												138.7 3523				
W121	VEHICLE WIDTH - REAR DOORS OPEN												1292 3282				
W121	VEHICLE WIDTH - REAR DOORS OPEN												NOT APPLICABLE				
H164	FIDUCIAL MARK TO GROUND - REAR												15.2 386	15.1 383	15.3 389	15.2 386	17.0 432
H138	DECK POINT TO GROUND	38.5 977		38.2 970	38.9 988	38.6 980	NOT APPLICABLE										
H127	HEADLAMP TO GROUND - CURB WEIGHT	27.7 703	26.9 683	27.2 691	27.7 703	27.5 698	27.0 686	28.2 716	28.0 711	28.3 719	28.0 711	27.6 701					
H128	TAIL LAMP TO GROUND - CURB WEIGHT	30.8 782	31.0 787	30.6 777	32.2 818	31.9 810	31.6 803	31.5 800	34.2 869	35.0 889	34.2 869	35.1 891	23.9 607				
H101	VEHICLE HEIGHT	55.1 1399	55.0 1397		55.4 1407	55.2 1402	55.7 1415	55.5 1410	63.2 1605	55.0 1397		56.0 1422					
H114	COWL POINT TO GROUND	37.9 963	37.6 955	37.9 963	38.5 973	38.2 970	37.9 963	37.7 957	38.9 988	38.7 985		39.3 998					
H112	ROCKER PANEL TO GROUND - FRONT	8.8 223	8.5 216	8.7 221	9.1 231	9.0 229	8.8 223	8.6 218	9.5 241	9.4 239		10.1 256					
H111	ROCKER PANEL TO GROUND - REAR	8.1 206	8.0 203	7.9 201	8.3 211		8.2 208	8.0 203	NOT APPLICABLE								
H132	BOTTOM OF DOOR TO GROUND, OPEN - FRONT	11.9 302	11.6 295	11.8 300	12.2 310	12.1 307	11.9 302	11.7 297	12.2 310			13.0 330					
H134	BOTTOM OF DOOR TO GROUND, OPEN - REAR	11.6 295	11.5 292		11.9 302	11.7 297	11.8 300	11.6 295	NOT APPLICABLE								
H122	WINDSHIELD SLOPE ANGLE												54°				
H125	HEADLAMP TO GROUND	26.7 678	25.8 655	26.3 668	26.8 680		26.6 676	26.1 663	28.4 721	28.5 724	28.3 719		28.2 716				
H126	TAIL LAMP TO GROUND	28.4 721	28.6 726	28.1 714	29.8 757	29.5 749	29.0 737	28.9 734	28.8 731	28.7 729	28.9 754	28.8 731	18.2 462				
H136	BODY BASE GRID 'Z' PLANE TO GROUND - FRONT	5.0 127	4.6 117	5.0 127	5.4 137	5.3 135	5.0 127	4.7 119	6.3 160	6.4 162	6.2 157		6.6 168				
H137	BODY BASE GRID 'Z' PLANE TO GROUND - REAR	4.7 119		4.5 114	4.9 124	4.7 119	4.9 124	4.7 119	3.7 94			5.2 132					
H135	BOTTOM OF DOOR TO GROUND, CLOSED - FRONT	11.9 302	11.8 300		12.2 310	12.0 305		11.9 302			12.9 328						
H135	BOTTOM OF DOOR TO GROUND, CLOSED - REAR	11.6 295	11.5 292	11.4 289	11.9 302	11.7 297	11.8 300	11.6 295	NOT APPLICABLE								
H158	ROOF THICKNESS	4.7 119						5.4 137	12.2 310		4.2 107						
H159	SIDE GLASS HEIGHT						14.4 366						14.8 376				
H160	BODY THICKNESS						27.7 703						27.4 696				
H195	LIFTOVER HEIGHT	25.6 650	25.7 653	25.3 643	25.8 655	25.4 645	NOT APPLICABLE										
H139	BOTTOM OF DOOR AJAR TO GROUND - FRONT	11.9 302	11.8 300		12.2 310	12.0 305		11.9 302			12.9 328						
H140	BOTTOM OF DOOR AJAR TO GROUND - REAR	11.6 295	11.5 292	11.4 289	11.9 302	11.7 297	11.8 300	11.6 294	NOT APPLICABLE								
H196	LIFTOVER HEIGHT CURB WEIGHT	28.0 711	28.1 714	27.8 706	28.5 724	27.8 706	NOT APPLICABLE										
H121	BACKLIGHT SLOPE ANGLE	33.5°			39°		34.5°		16.5°		9°						
PD1	PASSENGER DISTRIBUTION - FRONT												2				
PD2	PASSENGER DISTRIBUTION - REAR												3				
													GROSS VEHICLE MASS				

* GTS WHEN FITTED WITH ALLOY WHEELS
AFTER START OF PRODUCTION:
FRONT - 60.3 / 1532
REAR - 60.6 / 1539

Issued: JUNE, 1978 Revised:

HOLDEN 'IIZ' FEATURES

SPECIFICATIONS

BODY DIMENSIONS - EXTERIOR - INS.
mm.

		S E D A N						STATION WAGON			COMMERCIAL			
		KINGSWOOD		PREMIER	GTS	DEVILLE	CAPRICE	KINGSWOOD		PREMIER	PANEL VAN	UTILITY	CAB	
		P/O	SL					P/O	SL		K/WOOD	HOLDEN		K'WOOD
L106	OVERHANG - FRONT RPO	35.2 894	NOT APPLICABLE						35.2 894	NOT APPLICABLE		35.2 894		
L107	OVERHANG - REAR RPO	44.5 1130	NOT APPLICABLE						43.6 1107	NOT APPLICABLE		45.6 1158		
L108	VEHICLE LENGTH - RPO	190.7 4844	NOT APPLICABLE						192.8 4897	NOT APPLICABLE		194.8 4947		
L128	FRONT WHEEL CENTRE LINE TO BODY BASE GRID							18.2 462						
L101	WHEELBASE	111.0 2819				114.0 2896				120.4 3058				
L104	OVERHANG, FRONT	34.8 884	35.2 894	35.8 909	35.2 894	35.8 909	35.5 902	35.2 894	34.8 884	35.8 909	34.8 884			
L105	OVERHANG, REAR	44.3 1125	44.5 1130	45.2 1148	44.5 1130	54.3 1379	54.7 1389	43.6 1107	43.5 1105	43.6 1107	45.6 1158			
L103	VEHICLE LENGTH	190.1 4828	190.7 4844	192.0 4877	190.7 4844	204.1 5184	204.2 5187	192.3 4884	192.8 4897	193.4 4912	194.4 4938			
L126	FRONT END LENGTH							56.6 1437						
L123	UPPER STRUCTURE LENGTH	100.3 2548						122.9 3122		126.6 3216	53.7 1364	53.5 1359		
L129	REAR END LENGTH	28.6 2548			39.1 993			NOT APPLICABLE						
L127	REAR WHEEL CENTRE LINE TO BODY BASE GRID	92.8 2357						95.8 2433			102.2 2596			
L125	BODY BASE GRID PLANE TO WINDSHIELD COWL POINT							6.6 168						
L102	TYRE SIZE	SEE PAGES A-2, A-8, E-10 & F-11												

GROUND CLEARANCE

H102	FRONT BUMPER TO GROUND	16.2 411	12.2 310	16.2 411	13.2 335	14.1 358	16.1 409	12.4 315	18.1 460	18.2 462	17.9 455	17.2 437	
H104	REAR BUMPER TO GROUND	16.6 422	15.4 391	16.3 414	15.3 389	14.4 366	12.7 322	12.5 317	13.0 330	12.9 328	13.1 333	NOT APP.	
H106	ANGLE OF APPROACH	29°	23°	21°	25°	26°	28°	22°	29°				
	LIMITING STRUCTURAL COMPONENT	Valance Panel	Bumper Guard	Air Dam	Bumper Guard	Valance Panel	Bumper Guard	Valance Panel					
H147	RAMP BREAKOVER ANGLE	14°		13.5°	12°		14°		15°	14.5°	15°	15.5°	
H148	FRONT SUSPENSION TO GROUND	7.7 195	7.2 183	7.6 193	8.0 203	7.9 201	7.6 193	7.4 188	8.9 226	9.0 229	8.8 223	9.2 234	
	LIMITING STRUCTURAL COMPONENT	TIE MEMBER											
H150	FLYWHEEL/CON. HOUSING & TRANS. ASSY. TO GRD	8.8 223	7.4 188	7.9 201	7.8 198	8.7 221	7.6 193	9.7 246	9.6 244	5.7 246	10.2 259		
H151	FRAME TO GROUND	6.8 173	6.6 168	6.7 170	7.1 180	6.9 175	6.7 170	7.3 185			8.2 208		
H152	EXHAUST SYSTEM TO GROUND	6.8 173	6.6 168	6.4 162	5.8 147	5.6 142	6.8 173	6.7 170			7.5 190		
	LOCATION	EXHAUST PIPE			RESONATOR		EXHAUST PIPE						
H154	FUEL TANK TO GROUND	7.9 201	7.6 193	8.1 206	7.8 198	8.1 206	7.9 201	8.1 206			9.5 241		
H155	SPARE TYRE WELL TO GROUND	NOT APPLICABLE											
H156	MINIMUM RUNNING GROUND CLEARANCE	6.8 173	6.6 168	6.4 162	5.8 147	5.6 142	6.8 173	6.7 170			7.5 190		
	POSITION ON CAR	EXHAUST SYSTEM											
H107	ANGLE OF DEPARTURE	16.5°	17°	16°	14°	13°	15.5°	15°	12.5°	12°	13	12.5	21°
	LIMITING STRUCTURAL COMPONENT	EXHAUST PIPE											
H103	FRONT BUMPER TO GROUND - CURB WEIGHT	17.2 437	13.2 335	17.0 432	14.1 358	14.9 378	17.0 432	13.4 340	17.7 449	17.5 444	17.8 452	17.5 444	16.4 416
H105	REAR BUMPER TO GROUND - CURB WEIGHT	19.0 483	17.8 452	18.8 477	17.8 452	16.8 427	15.2 386	15.1 383	18.5 470	19.4 493	18.6 472	19.1 493	NA
H108	STATIC LOAD - TYRE RADIUS - FRONT	12.1 307	12.0 305	11.9 302	12.2 310	12.1 307	12.1 307	12.0 305	12.6 320	12.5 317	12.6 320		
H109	STATIC LOAD - TYRE RADIUS - REAR	12.0 305		11.9 302	12.1 307		11.8 300		12.0 305				
H153	REAR AXLE DIFFERENTIAL TO GROUND	7.7 195	7.5 190	7.9 201	7.7 195	7.7 195	7.9 201	7.7 195	6.7 170	6.6 168	6.7 170	7.3 185	
H149	OIL PAN TO GROUND	7.7 195	7.2 185	7.1 180	7.5 190	7.4 188	7.6 193	7.4 188	8.8 223	8.9 226	8.7 221	8.8 223	9.2 234

Issued: JUNE, 1978

Revised:

HOLDEN 'H2' FEATURES

BODY DIMENSIONS - INTERIOR - INS. - mm.

		SEDAN					STATION WAGON			COMMERCIAL			
		FINDSWOOD P/O	SL	PREMIER	GTE	BEVILLI	CAPRICE	FINDSWOOD P/O	SL	PREMIER	PANEL VAN K/WOOD/HOLDEN	UTILITY K/WOOD/HOLDEN	CAB CHASSIS
L30	FRONT OF DASH TO BASE GRID	MINUS 0.8											
H56	D POINT TO FLOOR	20.3											
H79	Sg RP DIFFERENTIAL, SIDE TO CENTRE	0.6 15.2	NOT APPLICABLE				0.6 15.2	NOT APPLICABLE		0.6 15.2			
W20	Sg RP Y CO-ORDINATE	14.5											
L31	Sg RP TO BODY BASE GRID	368											
H70	Sg RP TO BODY BASE GRID	42.1											
H61	EFFECTIVE HEAD ROOM	38.5 978					38.9 988			41.5 1054	38.3 973		
H37	HEADLINING TO ROOF PANEL	0.6 15.2								4.8 122	0.6 15.2		
L34	MAXIMUM EFFECTIVE LEG ROOM - ACCELERATOR	40.7											
H30	Sg RP TO HEEL POINT (CHAIR HEIGHT)	8.8 223	8.7 221	8.5 216	8.8 223	8.7 221	8.8 223	8.7 221	8.8 223	8.7 221	8.8 223		
H67	UNDEPRESSED FLOOR COVERING THICKNESS	0.5 12.7		0.8 20.3		0.5 12.7		0.4 10.2	0.5 12.7	0.4 10.2	0.5 12.7		
L40	BACK ANGLE	27°											
L42	HIP ANGLE	92°											
L44	KNEE ANGLE	117°											
L46	FOOT ANGLE	88°											
H65	D POINT DIFFERENTIAL, SIDE TO CENTRE	0.6 15.2	NOT APPLICABLE				0.6 15.2			0.6 15.2			
H54	D POINT CENTRE PASSENGER TO TUNNEL	1.6 40.6	NOT APPLICABLE				1.6 40.6			1.6 40.6			
L53	Sg RP FRONT TO HEEL	32.4 823			32.6 828		32.4 823						
L17	H POINT TRAVEL	4.8											
H58	H POINT RISE	122											
H75	EFFECTIVE T POINT HEADROOM	38.7 983					39.2 996			41.3 1049	38.5 978		
H68	DEPRESSED FLOOR COVERING THICKNESS	0.4 10.2		0.6 15.2		0.4 10.2							
W32	DRIVER HEAD CLEARANCE TO ROOF RAIL GARNISH	T O B E A D V I S E D											
W38	DRIVER HEAD CLEARANCE MINIMUM	T O B E A D V I S E D											
H35	DRIVER HEAD CLEARANCE TO ROOF LINING	3.1 78.7					3.5 88.9			7.0 178	2.9 73.7		
L38	DRIVER HEAD CLEARANCE TO WINDSHIELD CLEARANCE	15.9											
L14	SEAT BACK THICKNESS	5.4 137	4.8 122				5.4 137	4.8 122		5.4 137			
L18	ENTRANCE FOOT CLEARANCE	16.8 427	17.2 437				16.8 427	17.2 437		16.3 414			
H3	SEAT CUSHION HEIGHT	12.0 305	11.9 302	11.8 300		12.0 305	11.9 302		12.0 305				
W16	CUSHION WIDTH	52.0											
L9	SEAT DEPTH CUSHION	20.4 518	19.8 503				20.4 518	19.8 503		20.4 518			
H26	INTERIOR BODY HEIGHT AT ZERO Y PLANE	40.9 1039					40.8 1036			41.3 1049	48.3 1227		
H27	INTERIOR BODY HEIGHT AT Sg RP Y PLANE	45.0 1143					45.4 1153			52.3 1328	44.8 1138		
H77	SEAT BACK HEIGHT	27.9 709	27.8 706				27.9 709	27.8 706		27.9 709			
H32	CUSHION DEFLECTION	4.1 104	3.0 76.2				4.1 104	3.0 76.2		4.1 104			
H74	STEERING WHEEL TO CUSHION	4.0 102		3.7 93.9		4.0 102							
H130	STEP HEIGHT (CURB WEIGHT)	15.7 399	15.4 391	15.5 394	15.9 404	15.8 401	15.6 396	16.6 422	15.7 399	16.6 422	17.2 437		
W3	SHOULDER ROOM	59.2 1504	58.7 1491		58.8 1494	58.6 1488	59.2 1504	58.7 1491	59.2 1504				
W5	HIP ROOM	60.2 1529	59.2 1504	60.2 1529	59.2 1504	60.2 1529	59.2 1504	60.2 1529					
H50	UPPER BODY OPENING TO GROUND	50.2 1275	49.9 1267	50.0 1270	50.4 1280	50.3 1278	50.2 1275	50.0 1270	50.2 1275		51.3 1303		
H11	ENTRANCE HEIGHT	30.3											
H115	STEP HEIGHT (DESIGN LOAD)	14.1 358	13.8 350	14.0 355	14.1 358	14.3 363	14.1 358	14.0 355	14.4 366		15.3 389		

Issued: JUNE, 1978

Revised:

HOLDEN 'H2' FEATURES

SPECIFICATIONS

BODY DIMENSIONS - INTERIOR		- INS.		- mm.		SEDAN						STATION WAGON			COMMERCIAL						
		KINGSWOOD		PREMIER		GTS		DEVILIL		CAPRICE		KINGSWOOD		PREMIER	PANEL VAN	UTILITY	CAB				
		P/O	SL	P/O	SL	P/O	SL	P/O	SL	P/O	SL	P/O	SL	P/O	SL	K/WOOD	HOLDEN	V/WOOD	HOLDEN	CHASSIS	
H38	HEADLINING TO ROOF PANEL	0.6		15.2		0.9		22.8		0.7		17.8									
L51	MINIMUM EFFECTIVE LEG ROOM	35.3	897	34.5	876	36.3		922		38.1	968	36.4		924							
H31	Sg RP TO HEEL POINT (CHAIR HEIGHT)	11.7	297	11.6	295	11.5		292		11.6	295	11.5		292							
H73	DEPRESSED FLOOR COVERING THICKNESS	0.2		5.1																	
L48	KNEE CLEARANCE	0		2.0	50.8	3.7		93.9		1.6	40.6	3.7		93.9							
L3	REAR COMPARTMENT ROOM	24.8	630	26.7	678	28.8		731		27.0	686	28.9		734							
L41	BACK ANGLE			27°						25°				N							
L43	HIP ANGLE	87°		86°		89°				90°		87°		O							
L45	KNEE ANGLE	89°		86°		94°				103°		94°		T							
L47	FOOT ANGLE			114°				119°		120°		119°									
H66	D POINT DIFFERENTIAL SIDE TO CENTRE			0.8		20.3								A							
H55	D POINT CENTRE PASSENGER TO TUNNEL			1.7	43.2					1.8	45.7			P							
H76	EFFECTIVE T POINT HEADROOM			36.6	930			37.0	940			38.6	980	P							
L50	Sg RP COUPLE DISTANCE			31.7	805					33.7	856			L							
H57	D POINT TO FLOOR			4.0	102					4.1	104			I							
H80	Sg RP DIFFERENTIAL SIDE TO CENTRE			0.7		17.8								C							
W25	Sg RP 'Y' CO-ORDINATE	15.0		381		15.7		399		15.0		381		A							
W33	HEAD CLEARANCE TO ROOF RAIL GARNISH							TO BE ADVISED						B							
W39	HEAD CLEARANCE MINIMUM							TO BE ADVISED						L							
H36	HEAD CLEARANCE TO HEADLINING	0.8		20.3		1.3		33.0		3.2		81.2		E							
L39	HEAD CLEARANCE TO BACK WINDOW GARNISH	0.6		15.2		2.1		53.3		NOT APPLICABLE											
L35	Sg RP TO BODY BASE GRID	73.8		1874						75.8		1925									
H63	EFFECTIVE HEAD ROOM	37.1		942		37.2		945		38.6		980									
H71	Sg RP TO BODY BASE GRID			15.1		383															
H72	UNDEPRESSED FLOOR COVERING THICKNESS	0.5		12.7		0.6		15.2		0.5		12.7									
H131	STEP WEIGHT (CURB LOAD)	15.5	394	15.4	391	15.3	389	15.7	399	15.5	394	15.7	399	15.6	396	N					
H69	EXIT HEIGHT	28.8		731		29.1		739		29.7		754		O							
L19	ENTRANCE - FOOT CLEARANCE	12.5		317		13.3		338						T							
H33	SEAT CUSHION DEFLECTION	3.3	83.8	4.0		102				3.5		88.9									
L15	SEAT BACK THICKNESS	6.3	160	6.5	165	7.4		187		6.3		160		A							
H12	ENTRANCE HEIGHT	29.7		754		29.8		757						P							
H8	SEAT CUSHION HEIGHT	13.8	350	13.9	353	14.0		356		13.5	343	13.7	348	13.5		343		P			
H51	UPPER BODY OPENING TO GROUND	49.6	1260	49.5	1257	49.9		1267		49.7		1262		49.6		1260		L			
L16	CUSHION DEPTH	16.2		411		17.4		442		17.7		449		I							
H28	INTERIOR BODY HEIGHT AT ZERO 'Y' PLANE	39.7		1008		39.9		1013		40.9		1039		C							
H29	INTERIOR BODY HEIGHT AT Sg RP 'Y' PLANE	42.6		1082		43.0		1092		44.2		1123		A							
H78	SEAT BACK HEIGHT	25.0	635	24.4	620	24.8		630		24.9		632		B							
W4	SHOULDER ROOM	58.5	1486	58.1	1476	58.2		1478		57.7	1465	58.5		1486		1473		L			
W6	HIP ROOM	59.1	1501	58.1	1476	59.1	1501	57.7		1465		57.6		1463		E					
H116	STEP HEIGHT (DESIGN LOAD)	13.7	348	13.6	345	13.5	343	13.9	353	13.8		350		13.6		345					

Issued:

JUNE, 1978

Revised:

HOLDEN 'HIZ' FEATURES

SPECIFICATIONS

BODY DIMENSIONS - INTERIOR - INS.
- mm.

		S E D A N					S T A T I O N W A G O N			C O M M E R C I A L			
		KINGSWOOD P/O	SL	PREMIER	GTS	DEVILLE	CAPRICE	KINGSWOOD P/O	SL	PREMIER	PANEL VAN K'WOOD	UTILITY HOLDEN	CAB CLASSIS
W41	SIDE GLASS RADIUS							45.1					
								1145					
W122	TUMBLE HOME							25°					
H14	EYE ECLIPSE TO BOTTOM OF R.V. MIRROR							1.4					
H25	BELT HEIGHT - FRONT							35.6					
								16.1					
W7	STEERING WHEEL CENTRE 'Y' CO-ORDINATE							409					
								14.8					
								376					
W9	STEERING WHEEL OUTSIDE DIA. (MAXIMUM)	(A)		(B)	(A)	(B)	(A)						
H18	STEERING WHEEL ANGLE							20°					
H49	EYE ECLIPSE TO TOP OF STEERING WHEEL	1.4		1.2	1.4	1.1				1.4			
		35.6		30.5	35.6	27.9				35.6			
L7	STEERING WHEEL TURN CLEARANCE	13.2		13.0	13.2	13.0				13.2			
		335		330	335	330				335			
H13	STEERING WHEEL TO CENTRE LINE - THIGH	1.9		1.5	1.8	1.6				1.9			
		48.3		38.1	45.7	40.6				48.3			
L13	BRAKE PEDAL KNEE CLEARANCE	25.1		24.8				25.1					
		637		630				637					
L52	BRAKE PEDAL TO ACCELERATOR							1.3					
								33.0					
W122	TUMBLE HOME (LINEAR)							5.2					
								132					
S1	WINDSHIELD GLASS EXPOSED SURFACE AREA							1388					
								8955					
S2	SIDE GLASS EXPOSED SURFACE AREA	1513			1568		2570	780					
		9761			10116		16580	5032					
S3	BACK WINDOW/TAILGATE GLASS EXPOSED SURFACE AREA	1136			1037		664	466	544				
		7329			6690		4283	3006	3510				
S4	TOTAL GLASS EXPOSED SURFACE AREA	4037			3993		4662	2634	2712				
		26045			25761		29819	16993	17497				

CARGO SPACE DIMENSIONS

L200	CARGO LENGTH - OPEN - FRONT SEAT					99.5		99.2	N.A.		
						2527		2520			
L201	CARGO LENGTH - OPEN - 2ND SEAT	N				65.0		NOT APPLICABLE			
						1651					
L202	CARGO LENGTH - CLOSED - FRONT SEAT	O				79.2		83.1	N.A.		
						2012		2111			
L203	CARGO LENGTH - CLOSED - 2ND SEAT	T				44.8		NOT APPLICABLE			
						1138					
L204	CARGO LENGTH AT BELT - FRONT SEAT					67.0	68.5	75.4	N.A.		
						1702	1740	1915			
L205	CARGO LENGTH AT BELT - 2ND SEAT	A				33.9		NOT APPLICABLE			
						861					
L206	CARGO LENGTH AT ROOF - FRONT SEAT	P				59.8	61.3	71.2	NOT APPLICABLE		
						1519	1557	1808			
L207	CARGO LENGTH AT ROOF - 2ND SEAT	P				26.6		NOT APPLICABLE			
						676					
W200	CARGO WIDTH - FRONT	L				61.6		61.0	N.A.		
						1565		1549			
W201	CARGO WIDTH - WHEELHOUSE	I				48.0		48.2	N.A.		
						1219		1224			
W203	REAR OPENING WIDTH AT FLOOR	C				47.8		50.1	N.A.		
						1214		1272			
W204	OPENING WIDTH AT BELT	A				48.4		49.2	50.5	N.A.	
						1229		1250	1283		
W205	MINIMUM REAR OPENING WIDTH ABOVE BELT	B				42.7		39.6	NOT APPLICABLE		
						1084		1006			
H201	CARGO HEIGHT	L				30.2		40.1	NOT APPLICABLE		
						767		1018			
H202	REAR OPENING HEIGHT	E				27.3		36.0	NOT APPLICABLE		
						693		914			
H200	TAILGATE TO GROUND (CURB LOAD)					28.5		27.3	28.2	28.3	
						724		693	716	719	
V2	CARGO VOLUME (STATION WAGON)					71.5		NOT APPLICABLE			
						1816					
TRUNK LUGGAGE CAPACITY											
V1	USEABLE LUGGAGE CAPACITY	15.0	14.5	17.0	NOT APPLICABLE						
		425	411	481							

(A) 15.0 X 16.0 (381 x 406)

(B) 15.5 (394)

Issued: JUNE, 1978

Revised:

70.0
1.978

HOLDEN 'H2' FEATURES

SPECIFICATIONS

SHEETS 6 - 10 INCLUSIVE

THESE SHEETS WERE INCLUDED IN ORIGINAL ISSUE TO PROVIDE FOR BODY DIMENSIONS NOW SHOWN SHEETS 1 - 5 INCLUSIVE.

SHEET NUMBERS 6 - 10 RETAINED TO PRESERVE CONTINUITY OF SECTION SHEET NUMBERING AND THUS AVOID UNNECESSARY RE-ISSUE OF SHEETS 11 THRU 42.

ORIGINAL ISSUE SHEETS 6 THRU 10 DATED MAY 1977 SHOULD BE REMOVED FROM YOUR FILE.

Car club of Australia Inc

1740 x 767 x 1486

Issued: MAY, 1977

Revised: JUNE, 1978

HOLDEN 'HZ' FEATURES

SPECIFICATIONS

GLASS AREAS

MODELS	GLASS	TYPE	DAYLIGHT OPENING		THICKNESS	
			SQ. IN.	SQ. CM.	mm.	
ALL EXCEPT STATESMAN CAPRICE	WINDSHIELD	CURVED HEAT TREATED SAFETY PLATE WITH MODIFIED ZONE.	1388	8955	5.0 ± 0.2	
STATESMAN CAPRICE		LAMINATED WITH TINTED UPPER SHADED BAND			6.0 + 0.3 - 0.6	
SEDANS EXCEPT STATESMAN	REAR WINDOW	HEAT TREATED SAFETY SHEET	1136	7328	5.0 ± 0.2	
STATESMAN		HEAT TREATED SAFETY SHEET ELECTRICALLY HEATED (TINTED CAPRICE)	1037	6690	4.0 ± 0.2	
UTILITY, CHASSIS & CAB		END GATE	HEAT TREATED SAFETY SHEET	544	3510	5.0 ± 0.2
STATION SEDANS				664	4283	
PANEL VAN	FRONT DOOR (2 SIDES)	466		3009	4.0 ± 0.2	
ALL	REAR DOOR SLIDING (2 SIDES)	780		5032		
SEDANS	REAR DOOR FIXED (2 SIDES)	HEAT TREATED SAFETY SHEET	568	3664	4.0 ± 0.2	
STATION SEDANS			578	3729		
STATESMAN			569	3671		
SHORT WHEELBASE SEDANS			165	1066		
STATION SEDAN	REAR QUARTER		221	1426	5.0 ± 0.2	
STATESMAN			219	141		
STATION SEDAN			990	6387	5.0 ± 0.2	

TOTAL DAYLIGHT OPENING - SQ. IN. (sq. cm.)

SHORT WHEELBASE SEDANS	<u>4037</u>	(26045)
STATESMAN	3993	(25761)
STATION SEDANS	4622	(29819)
COUPE UTILITY & CHASSIS CAB	2712	(17497)
PANEL VAN	2634	(16993)

STATESMAN CAPRICE

TINTED UPPER SHADE BAND WINDSCREEN, TINTED SIDE WINDOWS, & TINTED HEATED REAR SCREEN.

Issued: MAY, 1977

Revised:

HOLDEN 'RZ' FEATURES

SPECIFICATIONS

SERIAL NUMBERS IDENTIFICATION AND LOCATION

ENGINE SERIAL NUMBER

HOLDEN ENGINE - L6

HOLDEN ENGINE - V8

LOCATION

L6 - ON PAD ABOVE ENGINE MOUNTING BOSSES
RIGHT HAND SIDE OF ENGINE.

V8 - ON PAD AT TOP FRONT LEFT SIDE OF
CYLINDER CASE.

ASSIGNMENT OF SERIAL NUMBERS

THE ENGINE SERIAL NUMBER PREFIX CONSISTS OF A TWO LETTER CODE. 'HX' ENGINES RETAIN 'HJ' & 'HQ' EXTERNAL FEATURES, I.E. OIL PAN SHAPE, ENGINE MOUNTING POINTS, ETC. THEREFORE, CODE LETTER 'Q' WILL CONTINUE AS FIRST LETTER OF 'HX' ENGINE CODES. SECOND CODE LETTER INDICATES ENGINE CHARACTERISTICS AND IS ALSO UNCHANGED FROM PREVIOUS MODEL SERIES.

THE ENGINE SERIAL NUMBER STARTS AT 1001 AND RUNS IN CONTINUOUS NUMERICAL SEQUENCE REGARDLESS OF ENGINE SIZE. ENGINE SIZE DESIGNATIONS ARE :-

<u>L6 ENGINE</u>		<u>V8 ENGINE</u>	
173 LC(2850)-	QE	253 LC (4.2)-	QS
173 HC(2850)-	QD	253 HC (4.2)-	QR
202 LC(3300)-	QM	308 HC (5.0)-	QT
202 HC(3300)-	QL		

EXAMPLE :-

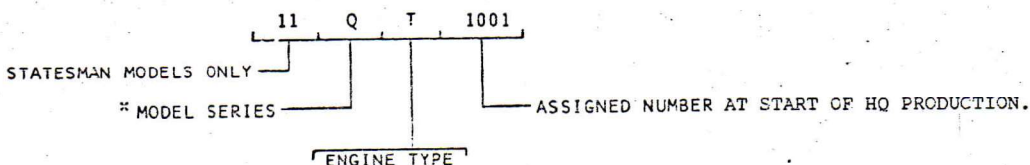

** 'Q' REFERS TO ENGINES WITH EXTERNAL FEATURES SAME AS HQ.

VEHICLE SERIAL NUMBER

LOCATION: STAMPED ON FRAME RIGHT HAND SIDE FRONT, IN ENGINE COMPARTMENT.

CODE : VEHICLE SERIAL NUMBER AT EACH BODY ASSEMBLY PLANT EXCEPT DANDENONG, STARTS AT 00001 AND IS PREFIXED BY MODEL SERIES AND SUFFIXED BY A PLANT LETTER WHERE THE BODY IS BUILT. DANDENONG COMMENCES AT 00021*

EXAMPLE :-

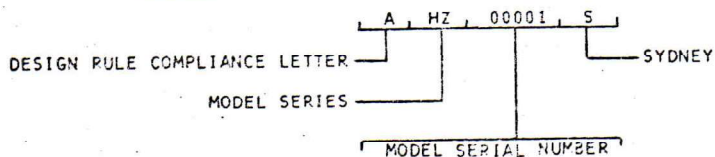

ALPHA CODE LETTER DENOTES COMPLIANCE WITH SAFETY DESIGN RULE.

LETTER STARTS AT 'A' AND ADVANCE TO 'B', 'C' ETC. WITH INTRODUCTION OF ADDITIONAL DESIGN RULES.

* FIRST 20 NUMBERS ARE RESERVED FOR PRE-TEST VEHICLES.

Issued: MAY, 1977

Revised:

136kg
 REAR LOAD
 H2 WAGON
 544 PAYLOAD

HOLDEN 'H2' FEATURES

SPECIFICATIONS

OPTION PENALTY WEIGHTS Kg. ONLY

OPTIONS OR ACCESSORIES	CHASSIS CAB	KINGSWOOD SL	PREMIER	GTS SEDAN	DEVILLE	CAPRICE	K'WOOD SL STATION	PREMIER WAGON	PANEL VAN & UTILITY	CALAIS	K'WOOD A9K	SANDMAN
3300 L6 3 SPEED MANUAL	STD	STD	NA	NA	NA	NA	STD	NA	STD	NA	STD	NA
3300 L6 4 SPEED MANUAL	NIL	NIL	Subtract 6.8	NA	NA	NA	NIL	Subtract 6.8	NIL	NA	NIL	NA
3300 L6 TRIMATIC	+ 6.8	+ 6.8	STD	NA	NA	NA	+ 6.8	STD	+ 6.8	NA	+ 6.8	NA
4.2 V8 3 SPEED MANUAL	+ 72	+ 72	NA	NA	NA	NA	+ 72	NA	+ 72	NA	+ 72	NA
4.2 V8 4 SPEED MANUAL	+ 73	+ 73	+ 66	STD	NA	NA	+ 73	+ 66	+ 73	NA	+ 73	STD
4.2 V8 TRIMATIC	+ 81	+ 81	+ 74	+ 8	NA	NA	+ 81	+ 74	+ 81	NA	+ 81	+ 8
5.0 V8 4 SPEED MANUAL	NA	+ 74	+ 67	+ 1	NA	NA	+ 74	+ 67	+ 74	NA	+ 74	+ 1
5.0 V8 TURBO HYDRAMATIC	NA	+100	+ 93	+ 27	STD	STD	+100	+ 93	+100	STD	+100	+ 27
BENCH FRONT SEAT	STD	Subtract 9	Subtract 9	NA	Subtract 9	NA	Subtract 9	Subtract 9	STD	Subtract 9	STD	NA
BUCKET FRONT SEAT	+ 9	STD	STD	STD	STD	STD	STD	STD	+ 9	STD	NA	STD
SIDE DOOR ELECTRIC LOCKS	NA	NA	NA	NA	+ 4	+ 4	NA	NA	NA	+ 4	NA	NA
CASSETTE TAPE/ RADIO (TBA)						UNIQUE SYSTEM						
POWER STEERING	+ 9	+ 9	+ 9	+ 9	STD	STD	+ 9	+ 9	+ 9	STD	+ 9	+ 9
POWER WINDOWS	NA	NA	+ 10	+ 10	+ 10	STD	NA	+ 10	NA	STD	NA	NA
POWER TAILGATE	NA	NA	NA	NA	NA	NA	+ 2	+ 2	NA	NA	NA	NA
DUAL EXHAUST	NA	+ 13	+ 13	STD	STD	STD	NA	NA	NA	STD	NA	NA
GROSS LOAD SUSPENSION												
OUTBACK SUSPENSION	NA	+ 9	+ 9	+ 9	+ 9	+ 9	+ 9	+ 9	+ 11	+ 9	+ 9	+ 11
CARPETS	Subtract 2	STD	STD	STD	STD	STD	STD	STD	Subtract 2	STD	NA	STD
FRONT AIR DAM (Not optional information only)	+ 1	+ 1	+ 1	STD	+ 1	+ 1	+ 1	+ 1	+ 1	+ 1	+ 1	STD
REAR DECK SPOILER	NA	+ 2	+ 2	STD	+ 2	+ 2	NA	NA	NA	+ 2	NA	NA
SEAT SEPERATOR	+ 3	STD	NA	NA	NA	NA	STD	NA	+ 3	NA	NA	NA
FLOORSHIFT CONSOLE	+ 6	+ 3	STD	STD	STD	STD	+ 3	STD	+ 6	STD	NA	STD
REAR WHEEL ANTI-LOCK	NA	NA	NA	NA	+ 5.5	+ 5.5	NA	NA	NA	+ 5.5	NA	NA
REAR WHEEL DISCS	NA	+ 10	+ 10	STD	STD	STD	+ 10	+ 10	+ 10	STD	+ 10	+ 10
TOW BAR	+ 12	+ 11	+ 11	+ 11	+ 11	+ 11	+ 11	+ 11	+ 12	+ 11	+ 11	+ 12
WINDSHIELD SUNSHADE	+ 3	+ 3	+ 3	+ 3	+ 3	+ 3	+ 3	+ 3	+ 3	+ 3	+ 3	+ 3
RUBBER MAT	STD	+ 2	NA	NA	NA	NA	+ 2	NA	+ 2	NA	+ 2	NA
5 CAST ALLOY WHEELS (TBA)	NA			STD						STD		
5 WIRE WHEELS	NA	NA	+ 15	+ 10	+ 15	+ 15	NA	+ 15	NA	+ 15	NA	NA
AIRCONDITIONING - L6 & V8 MAN.	+ 41	+ 41	+ 41	NA	NA	NA	+ 41	+ 41	+ 41	NA	+ 41	+ 41
AIRCONDITIONING - AUTO.	+ 43	+ 43	+ 43	+ 43	+ 43	STD	+ 43	+ 43	+ 43	STD	+ 43	+ 43
Rear Retractors		1kg	per	Year								

NA = NOT APPLICABLE
 TBA = TO BE ADVISED

Issued: MAY, 1977

Revised: AUGUST, 1977

HOLDEN '77Z' FEATURES

SPECIFICATIONS

WEIGHTS OF MODEL AND VEHICLE VARIANTS

MODEL	TARE Kg's ONLY	SHIPPING TOTAL	CURS			MAXIMUM LOADED VEHICLE WEIGHT *			
			TOTAL	FRONT	REAR	TOTAL	FRONT	REAR ANGLE ENGRG.	SALES
PASSENGER DERIVATIVE COMMERCIAL VS. UTILITY									
HOLDEN	1393	3055 1386	3170 1438			4850 2200			2900 1315
KINGSWOOD	1403	3078 1396	3192 1448			4850 2200			2900 1315
PANEL VAN									
HOLDEN	1456	3194 1449	3309 1501			4850 2200			2900 1315
KINGSWOOD	1467	3219 1460	3333 1512			4850 2200			2900 1315
CHASSIS & CAB									
HOLDEN	1314	2881 1307	1996 1359			5864 2660			3900 1700
COMMERCIAL DERIVATIVES WITH 10 cwt./500 kg PAYLOAD RATING. UTILITY									
						Estimated			
HOLDEN & L6	1313	2879 1306	2994 1358			3968 1800			2400 1089
HOLDEN & V8	1385	3038 1378	3152 1430			4189 1900			2460 1116
KINGSWOOD & L6	1323	2901 1316	3010 1368			3968 1800			2400 1089
KINGSWOOD & V8	1395	3060 1388	3175 1440			4189 1900			2460 1116
PANEL VAN									
						Estimated			
HOLDEN & L6	1376	3018 1369	3133 1421			4189 1900			2400 1089
HOLDEN & V8	1448	3177 1441	3291 1493			4299 1950			2460 1116
KINGSWOOD & L6	1387	3042 1380	3157 1432			4189 1900			2400 1089
KINGSWOOD & V8	1459	3201 1452	3316 1504			4299 1950			2460 1116
SANDMAN									
PANEL VAN	1499	3289 1492	3404 1544			4850 2200			
<i>Panel</i>	1436	3150 1429	3265 1481			4850 2200			
SANDMAN WITH 10 cwt./500 kg. PAYLOAD RATING									
						Estimated			
PANEL VAN	1496	3283 1489	3397 1541			4409 2000			
<i>Panel</i>	1433	3144 1426	3258 1478			4299 1950			
CHASSIS & CAB									
KINGSWOOD SL-L6									
KINGSWOOD SL-V8									

BALANCE : TO BE ADVISED

Issued: MAY, 1977

Revised: AUGUST, 1977

HOLDEN 'HZ' FEATURES

SPECIFICATIONS

FRONT SUSPENSION SPECIFICATIONS

DESCRIPTION Independent, SLA type with coil springs and concentric shock absorbers with spherical ball jointed steering knuckle for each wheel.
Lower control arms are linked to a rubber mounted stabilizer bar.

ROLL CENTRE HEIGHT - ABOVE GROUND @ DESIGN LOAD - ins. (mm.) Front 3.146" (79.91)

STEERING KNUCKLES
Spindle dia. ins. (mm.) 1.2493/ 1.2498 (31.72/ 31.75)
Inner Bearings7493/ .7498 (19.03/ 19.04)
Outer Bearings

WHEEL BEARINGS
Type Taper Roller
Lubricant
GM Wheel Bearing Grease HN 1227

SPHERICAL JOINTS
Lubricant Upper & Lower E.P. Grease Part No. 9935038

FRONT WHEEL ALIGNMENT AT CURB WEIGHT # Ø

CONDITION	SETTING	SPECIFICATIONS FOR ORIGINAL AND RESETTING ALIGNMENT		SPECIFICATIONS FOR DIAGNOSIS FOR WARRANTY REPAIR OR CUSTOMER PAID SERVICE	
		PER WHEEL	LIMIT*	PER WHEEL	LIMIT*
MANUAL STEERING	■Caster Degrees	½ to 1½ Pos.	½	0 to 2 Pos.	1
	■Camber Degrees	½ to 1½ Neg.	½	0 to 2 Neg.	1
	Toe-in Degrees	.15 to .45	.15 to .75	0 to .45	0 to .90
	Toe-in inches	1/16 to 3/16	1/16 to 5/16	0 to ½	0 to 3/8
	Toe-in mm.	1.6 to 5	1.6 to 8	0 to 6	0 to 9.5
POWER STEERING	Caster Degrees	2½ to 3½ Pos.	½	2 to 4 Pos.	1
	Camber Degrees	0 to 1 Neg.	½	0 to 1½ Neg.	1
	Toe-in Degrees	.15 to .45	.15 to .75	0 to .45	0 to .90
	Toe-in inches	1/16 to 3/16	1/16 to 5/16	0 to ½	0 to 3/8
	Toe-in mm.	1.6 to 5	1.6 to 8	0 to 6	0 to 9.5

= Steering Wheel must be locked in the straight ahead position within + 5 deg. Steering gear must be centralised within ± 20 deg. of gear input shaft rotation observe index markings.

* = Left and Right side camber and caster to be equal within limit shown

* = Toe-in equal within limit shown

Ø = Shimstacks must not exceed .5 in. 127 mm.

STABILIZER BAR - Diameter mm.- 24

FRONT SPRINGS

TYPE RH Helical coil inside diameter - ins. (mm.)
3.6 (91.4)

Issued: MAY, 1977 ■ Revised: AUGUST, 1977

HOLDEN 'HZ' FEATURES

SPECIFICATIONS

FRONT SPRING APPLICABILITY

ENGINE	MODEL	PART NO.	CONDITION
L6	SEDANS, STATION WAGONS	9946833	Standard
		9946834	C60 - Airconditioning
	PANEL VAN, UTILITY	2825748	Standard
		2825749	C60 - Airconditioning XW5 - Outback Package (without C60 Airconditioning)
		2825750	XW5 & C60 & FE7
		2825749	Standard
	CHASSIS AND CAB	2825750	C60 - Airconditioning
		9946835	Standard
V8	SHORT WHEELBASE SEDANS STATION WAGONS	9946838	C60 - Airconditioning
		9946837	Standard
	STATESMAN DEVILLE & CALAIS	9946837	C60 - Airconditioning
	STATESMAN CAPRICE	9946836	Standard
	CHASSIS AND CAB, PANEL VAN, UTILITY	2825750	Standard

Issued: MAY, 1977 Revised: AUGUST, 1977

HOLDEN 'H2' FEATURES

SPECIFICATIONS

FRONT SPRING SPECIFICATIONS

PART NO.	WIRE DIA.	NO. OF COILS		HEIGHT - INS. (mm)		DEFLECTION RATE LBS/IN (kN/m)		
	INS. (mm.)	ACTIVE	TOTAL	FREE	WORKING @ LBS.(N)	AT SPRING	AT WHEEL	
2825748	.649 (16.5)	7.07	8.46	13.20 (335.3)	9.50 (241.30)	1740 (7743)	470 (82)	118 (21)
2825749	.649 (16.5)	7.07	8.46	13.44 (341.4)		1850 (8232)	470 (82)	118 (21)
2825750	.649 (16.5)	7.07	8.46	13.82 (351.0)		2030 (9033)	470 (82)	118 (21)
9946833	.609 (15.5)	7.91	9.30	14.31 (363.5)		1610 (7164)	335 (59)	84 (15)
9946834	.648 (16.4)	8.94	10.33	14.23 (361.4)		1750 (7787)	370 (65)	TBA
9946835	.648 (16.4)	8.16	9.55	14.12 (358.6)		1870 (8321)	405 (71)	101 (18)
9946836	.669 (17.0)	8.76	10.15	14.65 (372.1)		2150 (9567)	420 (73)	TBA
9946837	.648 (16.4)	7.87	9.26	14.37 (365.0)		2050 (9122)	420 (73)	TBA
9946838	.648 (16.4)	7.87	9.26	14.17 (360.0)		1970 (8766)	420 (73)	TBA

FRONT SHOCK ABSORBERS

ENGINE	MODEL	DIAMETER	CONDITION	VALVE CODE	PART NO.
L6	ALL PASSENGER MODELS	1.62" (41 MM)	WITHOUT AIR-COND.	ZFE1.51515,151Y20	9946840
		1.748 (44.4)	WITH AIR-COND.	TBA	92001182
L6 & V8	COMMERCIALS		ALL	2FB120,20,201Y20	9946841

Issued: MAY, 1977 Revised: AUGUST, 1977

HOLDEN 'H.Z.' FEATURES

SPECIFICATIONS

REAR AXLE AND REAR SUSPENSION SPECIFICATIONS

REAR AXLE

GENERAL

ALL 6 CYLINDER MODELS EXCEPT CHASSIS 8 CAB

STAMPED AND WELDED 0.164 IN. (4.17MM)
BANJO TYPE HOUSING WITH PRESSED ENDS.

CHASSIS CAB AND V8 MODELS

SALISBURY TYPE WITH CAST CENTRE AND
PRESSED AND WELDED STEEL TUBES OF
0.15 IN. (3.81MM) PASSENGER, AND 0.18 IN.
(4.57MM) COMMERCIAL VEHICLES.

REAR AXLE

	BANJO				SALISBURY				
	3.08	3.36	3.55	3.90	2.60	3.08	3.36	3.55	4.44 **
RATIO :1	3.08	3.36	3.55	3.90	2.60	3.08	3.36	3.55	4.44 **
HYPOID GEAR	40	37	39	39	39	40	37	39	40
NO. TEETH	7.0 (177.8)				7.5 (190.5)				
DIAMETER INS. (MM)									
PINION GEAR	13	11	11	10	15	13	11	11	9
NO. TEETH	1.25 (31.75)				1.375 (34.9)				
OFFSET INS. (MM)									
MATERIALS:-									
CASE	NODULAR IRON								
CARRIER	GREY CYLINDER CAST IRON				NODULAR IRON				
HYPOID GEARS	FINE GRAIN STEEL FORGING								
AXLE SHAFT	FINE GRAIN STEEL FORGING								
BEARINGS									
WHEEL BEARING	TIMKEN TAPER ROLLER UNIT BEARING								
PINION FRONT AND REAR	TAPER ROLLER								
FINAL DRIVE	TAPER ROLLER								

LUBRICANT TYPE AND CAPACITY-IMP.PTS.(LITRES) HYPOID GEAR OIL MN-1386 2.5(1.42)
LIMITED SLIP DIFFERENTIAL (P.O. G80) HYPOID GEAR OIL GMH 9985035 2.5(1.42)

DRIVE AND BRAKING TORQUE :

PASSENGER VEHICLES TAKEN THROUGH SUSPENSION ARMS.

COMMERCIAL VEHICLES TAKEN THROUGH REAR SPRINGS.

** DUE TO THE LOW RATIO VEHICLES FITTED WITH THIS REAR AXLE RATIO REQUIRE AN ENGINE/VEHICLE SPEED WARNING NOTICE.

Issued: MAY, 1977 Revised:

HOLDEN 'HZ' FEATURES

SPECIFICATIONS

REAR AXLE AND REAR SUSPENSION

REAR SUSPENSION

TYPE:

ALL EXCEPT COMMERCIAL VEHICLES ..

FOUR LINK TYPE UTILIZING RUBBER BUSHED ANGLED UPPER CONTROL ARMS TO PROVIDE FORE AND AFT AND SIDEWAYS AXLE LOCATION WITH PARALLEL LOWER CONTROL ARMS. AXLE MOUNTED COIL SPRINGS AND ANGLED DIRECT ACTING SHOCK ABSORBERS WITH AXLE MOUNTED STABILIZER BAR CONNECTED TO THE UPPER SUSPENSION MOUNTING SUB FRAME WITH RUBBER INSULATED LEADING LINKS.

COMMERCIAL VEHICLES ..

SEMI ELLIPTICAL SPRINGS WITH BONDED STEEL SLEEVE FRONT SHACKLE BUSH AND TWO PIECE RUBBER COMPRESSION TYPE REAR SHACKLE MOUNTING. ANGLED DIRECT ACTING SHOCK ABSORBERS. AXLE MOUNTED STABILIZER CONNECTED TO THE CHASSIS WITH RUBBER INSULATED TRAILING LINKS.

SPRINGS

TYPE:

ALL EXCEPT COMMERCIAL VEHICLES

.. .. RH HELICAL COIL

COMMERCIAL VEHICLES

.. .. SEMI-ELLIPTIC

SHOCK ABSORBERS

TYPE:

.. .. DIRECT ACTING (DOUBLE ACTING)

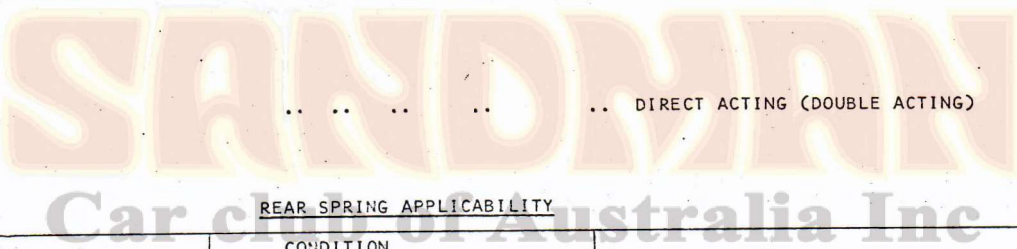

REAR SPRING APPLICABILITY

MODEL	CONDITION F72 = GROSS LOAD EQUIPMENT XW5 = OUTBACK PACKAGE EQUIP. = H/D FRONT & REAR SUSP.	PART NUMBER
SHORT WHEELBASE SEDAN	STANDARD	9946848
STATESMAN	STANDARD	9947878
STATION WAGON	STANDARD	9946849
CHASSIS AND CAB	STANDARD	9935932/34
PANEL VAN AND UTILITY	F72, XW5, FE7	
	STANDARD	9935933/35

STABILIZER BAR - DIAMETER MM.

L6

14

V2

16

COIL SPRINGS

MATERIAL

SILICON MANGANESE STEEL

INSIDE DIAMETER

4.80 INS. (122.32 MM.)

Issued: MAY, 1977

Revised: AUGUST, 1977

HOLDEN 'HZ' FEATURES

SPECIFICATIONS

PASSENGER

REAR COIL SPRING SPECIFICATIONS

PART NUMBER	GAUGE	NO. OF COILS		HEIGHT		DEFLECTION RATE	
	IN. (mm)	ACTIVE	TOTAL	FREE IN. (mm)	WORKING @ mm	LBS. (N)	AT SPRING LBS/INS
9947878	.572 (14.5)	7.13	8.56	14.8 (375.9)	8.10	970 (4316)	145 (25.4)
9946848	.572	7.13	8.56	14.3 (363.2)		900 (4005)	145 (25.4)
9946849	.570 (14.5)	5.99	7.42	14.72 (373.9)		1100 (4895)	165 (28.9)

REAR SHOCK ABSORBERS

CONDITION	DIAMETER	VALVE CODE	PART NO.	MODEL
STANDARD	1.75 (44.4)	ZFC3,12,12,15-5Y8	9946855	STATION WAGONS
		ZF84,10,10,10,2215	9946856	SEDANS, EXCEPT GTS

COMMERCIAL

REAR LEAF SPRING SPECIFICATIONS

PART NUMBER	MAIN LEAF LENGTH mm. (INS)	WIDTH OF LEAVES mm. (INS)	NUMBER OF LEAVES	LEAF THICKNESS mm.	LOAD NEWTONMETRES @ CAMBER mm.		RATE kN/m
					RH	LH	
9935935 RH 9935933 LH	1372 (54)	65 (2.5)	PRIMARY - 3	8.0	3270 @ 66	2800 @ 66	29.3
SECONDARY- 1			13.0	6565 @ 13	6065 @ 13	51.8	
9935934 RH 9935932 LH			PRIMARY - 3	7.5	2725 @ 91	2275 @ 91	39
SECONDARY- 3			13.0	7825 @ 25	7400 @ 25	11.1	

REAR SHOCK ABSORBERS

CONDITION	DIAMETER INS. (mm)	VALVE CODE	PART NO.	MODEL
STANDARD	1.75 (44.4)	ZFA4G10-2Y11	9947908	ALL
F72 GROSS LOAD PACKAGE FE7 HD F & R SUSPENSION	1.62 (41.1)	ZFC2.5L12-2Y9	9946655	UTILITY & PANEL VAN

Issued: MAY, 1977 Revised: AUGUST, 1977

HOLDEN 'HZ' FEATURES

SPECIFICATIONS

PROPELLER SHAFT APPLICABILITY

ENGINE	TRANSMISSION	WHEELBASE - INS. (CM)	PROPELLER SHAFT PART NUMBER
L6	3 SPD. 4 SPD. TRIMATIC	111 (281.9)	2814337
	3 SPD. 4 SPD	114 (289.6)	2814287
	TRIMATIC		2814338
	3 SPD. 4 SPD. TRIMATIC	120.4 (305.8)	9929974
V8	3 SPD. 4 SPD. TRIMATIC	111 (281.9)	2814339
	TURBO HYDRAMATIC		9933672
	3 SPD. 4 SPD. TRIMATIC	114 (289.6)	2814340
	TURBO HYDRAMATIC		9933673
	3 SPD. 4 SPD. TRIMATIC	120.4 (305.8)	9929265
	TURBO HYDRAMATIC	120.4 (305.8)	9935855

PROPELLER SHAFT SPECIFICATIONS

PART NUMBER	LENGTH C/L TO C/L OF U JOINTS INS. (CMS)	OUTSIDE DIA. INS. (MM)	WALL THICKNESS INS. (MM)	NO. OF SPLINES
2814337	57.3 (146)	2.75 (69.9)	.065 (1.7)	27
2814339	56.3 (143)			
9933672				
2814287	60.3 (153.2)	3.0 (76.2)	.065 (1.7)	27
2814340	59.3 (150.6)			
2814338	60.3 (153.2)	2.75 (69.9)	.065 (1.7)	31
9933672	55.6 (141.2)			
9933673	58.6 (148.8)	3.0 (76.2)	.072 (1.8)	27
9929974	65.8 (167.1)	3.3 (83.8)		
9929265				
9935855	65.18 (165.56)	3.5 (88.9)	.072 (1.8)	31

Issued: MAY, 1977

Revised:

HOLDEN 'H2' FEATURES

SPECIFICATIONS

ENGINE DATA

1976 ADR EMISSION ENGINES

ENGINE DESIGNATION	3,3 HC MANUAL	3,3 LC MANUAL	3,3 HC AUTO.		4.2 HC	5.0 HC
ACTUAL PISTON DISPLACEMENT	3.298				4.142	5.044
LITRES - ℓ	201.25				252.81	307.83
CU. INS.	9.2	7.5	9.2		9.4	9.4
■ COMP. RATIO :1 (MAX.)	97	87	97		97	97
PETROL RESEARCH OCTANE RATING	SIX				EIGHT	
NUMBER OF CYLINDERS	3.625 x 3.250				3.625 x 3.062	4.000 x 3.062
BORE INS.	92.075 x 82.550				92.075 x 77.775	101.600 x 77.775
STROKE mm.	31.5				42.0	51.2
TAXABLE HORSEPOWER RAC OR SAE	109	102	118		161	216
BRAKE HORSEPOWER GROSS @ RPM.	3900	4000	4000		4550	4800
GM TEST 20 GROSS	81	76	88		120	161
KILLOWATTS GROSS @ RPM.	3900	4000	4000		4550	4800
GM TEST 20 GROSS kw.	185	181	185		240	295
TORQUE LBS/FT. GROSS @ RPM.	1400	1200	2100		2600	3100
GM TEST 20 GROSS	251	245	251		325	400
TORQUE NEWTON METRES GROSS @ RPM.	1400	1200	2100		2600	3100
GM TEST 20 GROSS Nm	.55	.51	.61		.63	.70
DISPLACEMENT GROSS BHP/CU. IN.	25	23	27		29	32
DISPLACEMENT GROSS kW/LITRE	850				900	850
IDLE SPEED MANUAL TRANSMISSION	IDLE SPEED AND MIXTURE PRESET - NOT TO BE RE-ADJUSTED					
IDLE SPEED AUTO TRANSMISSION	650 DRIVE				625 DRIVE	
COMP. PRESSURE HOT CRANKING	TO BE EQUAL WITHIN 20 PSI (140 KPA)					

ENGINE WEIGHTS LBS. (Kg's.)

ENGINE ASM. AS SHIPPED	
3 & 4 SPEED	TO BE ADVISED
AUTOMATIC	
POWER PLANT ASM.	
3 SPEED	TO BE ADVISED
4 SPEED	
AUTOMATIC	

3.3 L.C. AUTO. CANCELLED AFTER JANUARY 1, 1978.

Issued: MAY, 1977 ■ Revised: JULY, 1978

HOLDEN 'HZ' FEATURES

SPECIFICATIONS

ENGINE DATA EXPORT ENGINE RANGE

ENGINE DESIGNATION	2,8 HC	2,8 LC	3,3 HC	3,3 LC	4,2 HC	5,0 HC
ACTUAL PISTON DISPLACEMENT	2.838		3.298		4.142	5.044
LITRES - l	173.16		201.25		252.81	307.83
CU.INS.	9.4	8.3	9.4	7.8	9.0	9.7
COMP. RATIO :1 (MAX.)	97	87	97	87	97	
PETROL RESEARCH OCTANE RATING	SIX					
NUMBER CYLINDERS	EIGHT					
BORE	3.500 x 3.000		3.625 x 3.250		3.625 x 3.062	4.000 x 3.062
INS.	88.900 x 76.200		92.075 x 82.550		92.075 x 77.775	101.600 x 77.775
STROKE	29.4		31.5		42.0	51.2
TAXABLE HORSEPOWER RAC OR SAE	105 @ 4000	95 @ 4200	110 @ 4000	100 @ 3600	175 @ 4800	250 @ 5000
BRAKE HORSEPOWER GROSS @ RPM.	78 @ 4000	71 @ 4200	82 @ 4000	75 @ 3600	130 @ 4800	186 @ 5000
KILLOWATTS GROSS @ RPM.	165 @ 2400	150 @ 2000	190 @ 1600	180 @ 1600	240 @ 3000	320 @ 3400
TORQUE LBS./FT. GROSS @ RPM.	224 @ 2400	203 @ 2000	258 @ 1600	244 @ 1600	325 @ 3000	434 @ 3400
TORQUE NEWTON METRES GROSS @ RPM.	.61	.55		.50	.69	.81
DISPLACEMENT GROSS BHP/CU. IN.	27	25		23	31	37
DISPLACEMENT GROSS KW/LITRE	650					
IDLE SPEED MANUAL TRANSMISSION	IDLE SPEED AND MIXTURE PRESET - NOT TO BE RE-ADJUSTED					
IDLE SPEED AUTO TRANSMISSION	575 DRIVE					
COMP. PRESSURE HOT CRANKING	TO BE EQUAL WITHIN 20 PSI (140 KPA)					

ENGINE ASM. AS SHIPPED

3 & 4 SPEED	TO BE ADVISED
AUTOMATIC	

POWER PLANT ASM.

3 SPEED	TO BE ADVISED
4 SPEED	
AUTOMATIC	

Issued: MAY, 1977

Revised: AUGUST, 1977

HOLDEN 'HIZ' FEATURES

SPECIFICATIONS

ENGINE DATA

CAR PERFORMANCE DATA

TYRE SIZE (BASE)	PERF COND.	AXLE RATIO :1 ENGINE	2.60		3.08			3.36			3.55			3.90		4.44		
			4.2 5.0	2,8	3,3	4,2 5,0	2,8	3,3	4,2 5,0	2,8	3,3	4,2 5,0	2,8	3,3	2,8	3,3	4,2 5,0	

Model	Description	1232		1330		1344		1451		1420		1534		1560		1685		
		(235)	(252)	(254)	(275)	(269)	(290)	(295)	(319)									
E78S14 E78L14 195SR14LT	PISTON TRAVEL DIRECT RATIO FEET/ MILE (METRES/KILOMETRES)	1166	1347	1273	1469	1388	1553	1468										
ER78S14		(221)	(255)	(241)	(278)	(263)	(294)	(278)										
ER70H14		1153		1279		1393		1473										
FR78S14		(218)		(242)		(264)		(279)										
F78L14 195SR14		1126		1248		1361		1439										
F78-14LT		(213)		(236)		(258)		(272)										
		1119	1215	1312	1240	1325	1431	1352	1400	1512	1430	1538	1662					
		(212)	(230)	(248)	(235)	(251)	(271)	(256)	(265)	(286)	(271)	(291)	(315)					
						1304	1408	1330	1377	1487	1406			1723	1855	1758		
						(247)	(267)	(252)	(261)	(282)	(265)			(326)	(351)	(333)		

Model	Description	41.1		44.8		47.3		52.0	
		(25.5)	(27.8)	(29.4)	(32.3)				
E78S14 E78L14 195R14LT	ENGINE RPM/MPH RPM/ KMH	37.5	41.6	45.4	47.9				
ER78S14		(23.3)	(25.8)	(28.2)	(29.8)				
ER70H14		37.7	41.7	45.5	42.1				
FR78S14		(23.4)	(25.9)	(28.3)	(29.9)				
F78L14 195SR14		36.8	40.7	44.5	47.0				
F78-14LT		(22.9)	(25.3)	(27.6)	(29.2)				
			40.5	44.2	46.7	51.3			
		(22.7)	(25.2)	(27.5)	(29.0)	(31.9)			
				43.4	45.9	57.4			
				(27.0)	(28.5)	(35.7)			

Issued: MAY, 1977

Revised: AUGUST, 1977

HOLDEN 'HZ' FEATURES

SPECIFICATIONS

ENGINE DATA

CAR PERFORMANCE DATA (Continued...)

3.55
3.36

TYRE SIZE (BASE)	PERF. COND.	AXLE RATIO	2.60		3.08			3.36			3.55			3.90		4.44		
		ENGINE	4.2 5.0	2.8	3.3	4.2 5.0	2.8	3.3	4.2 5.0	2.8	3.3	4.2 5.0	2.8	3.3	2.8	3.3	4.2 5.0	

E78S14 E78L14 195R14LT	TOP GEAR MPH/1000 ENGINE RPM (KMH/1000 ENGINE RPM)		24.5 (39.4)	22.5 (36.2)	21.3 (34.3)	19.3 (31.0)	
ER78S14		28.5 (45.8)	24.0 (38.6)	22.0 (35.4)	20.9 (33.6)		
ER70H14		28.4 (45.7)	23.9 (38.4)	21.9 (35.3)	20.3 (33.5)		
FR78S14		29.1 (46.8)	24.5 (39.4)	22.5 (36.2)	21.3 (34.3)		
F78L14 195SR14			24.7* (39.7)	22.6 (36.4)	21.4 (34.4)	19.5 (31.4)	
F78-14LT				23.0 (37.0)	21.3 (35.1)		17.4 (28.0)

HOLDEN 'HZ' FEATURES

SPECIFICATIONS

ENGINE DATA

THE 'HZ' ENGINE RANGE CONSISTS OF CARRYOVER 'HX' ENGINES.

PRINCIPAL COMPONENTS

CYLINDER HEAD

MATERIAL	CAST IRON
COMBUSTION CHAMBER VOLUME WITH VALVES AND SPARK PLUG IN PLACE.			
L6 - 2850 HC,	45.37 ± 1.0CC
2850 LC, 3300	53.50 ± 1.0CC
V8 - 4.2, 5.0	55.60 ± 1.0CC

CYLINDER BLOCK

MATERIAL	CAST IRON
BORE - INS. (MM)			
L6 - 2850	3.5000/3.5030 (88.9004/88.9766)
3300, V8-4.2..	3.6250/3.6280 (92.0754/92.1516)
V8 - 5.0	4.0000/4.0030 (101.6004/101.6766)

CRANKSHAFT

MATERIAL	NODULAR CAST IRON
WEIGHT LBS. (KG) NOM.			
L6 - 2850	44.1 (20.00)
3300	48.0 (21.77)
V8 - 4.2	50.4 (22.86)
5.0	52.0 (23.59)
COUNTER WEIGHTS			
L6	4
V8	6

CRANKSHAFT (CONTD.)

STROKE - INS. (MM)	
L6 - 2850	2.995/3.005 (76.0733/76.3273)
3300	3.245/3.255 (82.4233/82.6773)
V8	3.057/3.067 (77.6481/77.9021)
JOURNAL DIAMETER - INS. (MM)			
L6	2.497/2.498 (63.4240/63.4494)
V8	2.397/2.398 (60.8840/60.9094)
TORSIONAL DAMPER PULLEY DIA. - INS. (MM)			
L6	5.90 (149.86)
V8	6.03 (153.16)

MAIN BEARINGS

TYPE	PRECISION REMOVABLE
MATERIAL			
L6, V8 NUMBER	COPPER/LEAD STEEL BACKED
L6	7
V8	5
DIAMETRAL CLEARANCE - INS. (MM)			
	0010/0018 (.0254/.0457)
END THRUST - INS. (MM) NOM.			
002/.006 (.0508/.1524)
CRANKPIN JOURNAL DIA. - INS. (MM)			
L6	1.899/1.900 (48.2348/48.2602)
V8	2.124/2.125 (53.9492/53.9752)

Issued: MAY, 1977

Revised:

HOLDEN 'HZ' FEATURES

SPECIFICATIONS

ENGINE DATA

PRINCIPAL COMPONENTS (CONT'D)

FLYWHEEL MANUAL TRANSMISSION

WEIGHT INC. RING GEAR - LBS. (kg.)	
L6	23.86 (10.83)
V8	32.13 (14.57)

CAMSHAFT

MATERIAL	LOCATION	CAST IRON
L6	IN CRANKCASE - TOP RH SIDE	
V8	IN CRANKCASE - ABOVE CRANKSHAFT	
END PLAY - INS. (mm)		
L6	.002/.006 (.0508/.1524)	
V8	.002/.014 (.0508/.3556)	

DRIVE TYPE

L6	GEAR
V8	SINGLE ROW CHAIN

PISTONS

MATERIAL	ALUMINIUM ALLOY TIN PLATED
FEATURES	SIDE RELIEVED TRUNK TYPE WITH STRUT AND TRANSLOT

TOP FEATURES & CAPACITY cc's

2850 LC CAVITY	3.71
2850 HC	1.92
3300 LC CAVITY	19.89
3300 HC	2.36
4.2 LC CAVITY	FLAT - EXPORT ENC.
4.2 HC SPERICAL DOME	3.34 LOCAL ENG.
5.0 CAVITY	9.25

*PISTON DIAMETER - INS. (mm)

L6 - 2850	3.4992/3.4995 (88.8800/88.8876)
- 3300	3.6242/3.6272 (92.0550/92.1312)
V8 - 4.2	3.6239/3.6269 (92.0474/92.1236)
- 5.0	3.9989/4.0019 (101.5725/101.6487)

PISTONS (Cont'd....)

SKIRT CLEARANCE IN BORE - INS. (mm)	
L6	.0005/.0011 (.0127/.0279)
V8	.0008/.0014 (.0203/.0356)

* AT DIA. 2.0 INS. (50.8mm) FROM PISTON TOP

TOP LAND CLEARANCE IN BORE - INS. (mm)	
L6 - 2850	.0330/.0440 (.8382/1.1176)
- 3300	.0340/.0450 (.8636/1.1430)
V8 - 4.2	.0340/.0450 (.8636/1.1430)
- 5.0	.0370/.0460 (.9398/1.1684)

PIN BORE OFFSET - INS. (mm) NOM. .060 (1.52)

COMPRESSION HEIGHT - INS. (mm)	
2850	1.799/1.801 (45.69/45.74)
3300	1.674/1.676 (42.51/42.57)
4.2 & 5.0	1.700/1.702 (43.18/43.23)

PISTON WEIGHT - (grams.) NOM.

L6 - 2850	455
3300	466
V8 - 4.2	509
5.0	632

PISTON PINS

TYPE ... SEMI FLOATING RETAIN IN CON RODS

DIAMETER - INS. (mm)	
L6	.8660/.8663 (21.9965/22.0041)
V8	.9270/.9273 (23.5459/23.5535)

LENGTH - INS (mm) NOM.

L6	2.72 (69.0883)
V8 - 4.2	2.72 (69.0883)
5.0	2.88 (73.1523)

DIAMETRAL CLEARANCE IN PISTON - INS. (mm) .00015/.00025
(.0038/.0064)

INTERFERENCE FIT IN CON ROD... .0008/.0016
(.0204/.0407)

COMPRESSION RING UPPER

MATERIAL	CAST IRON
TYPE	BALANCED SECTION
FINISH	BARREL LAPPED MOLYB-DENUM FILLED
WIDTH - INS. (mm)	.0775/.0780 (1.9685/.1.9812)
GAP - INS. (mm) NOM.	.010/.020 (.25/.50)

Issued: MAY, 1977

Revised:

HOLDEN 'HZ' FEATURES

SPECIFICATIONS

ENGINE DATA

PRINCIPAL COMPONENTS (CONT'D)

COMPRESSION RING LOWER

MATERIAL	CAST IRON
TYPE				
L6	TAPERED FACE TORSIONAL
V8	TAPERED FACE TORSIONAL REVERSE TWIST
FINISH	WEAR RESISTANT COATING
WIDTH - INS. (MM)0775/.0780 (1.9685/1.9812)
GAP - INS. (MM)				
L6 - V8	4.2010/.020 (.25/.50)
	5.0011/.021 (.28/.53)

OIL CONTROL RING

MATERIAL	STEEL
TYPE	SEGMENTED (2) WITH CIRCUMFERENTIAL EX- PANDER TYPE SPACER
FINISH	CHROME PLATED PERIPHERY
RAIL GAP - INS. (MM) NOM.015 / .055 (.38/1.39)
EXPANDER GAP	+.19 / -.19

CONNECTING RODS

MATERIAL	STEEL FORGING
ASSEMBLY WEIGHT LESS BEARING SHELLS - OZ. (GRMS.) NOM.				
L6	15.5 (481)
V8	18.9 (588)
END PLAY				
L60085/.0135 (.2159/.3429)
V8008/.014 (.2032/.3556)

CRANKPIN BEARING

TYPE	PRECISION REMOVABLE STEEL BACKED
MATERIAL	COPPER / LEAD
DIAMETRAL CLEARANCE - INS. (MM)				
L60010/.0018 (.0254/.0457)
V80007/.0022 (.0178/.0559)

VALVE TRAIN

TYPE	INCLINED PUSH ROD OPERATED OVERHEAD VALVES WITH NON- ADJUSTABLE ROCKER ARMS MOUNTED IN PAIRS
LIFTERS	HYDRAULIC
VALVE SEATS					
DESCRIPTION	CUT IN CYLINDER HEAD
SEAT / FACE ANGLES - DEG.					

EXHAUST

	EXHAUST	HEAD SEAT	VALVE FACE		
..	46	45
..	46	45
EXHAUST SEAT WIDTH IN HEAD - INS. (MM)					
L6062/.093 (1.5784/2.3622)	
V8050/.075 (1.2700/1.9050)	
INLET SEAT WIDTH IN HEAD - INS. (MM)035/.060 (.8890/1.5240)	

VALVE EXHAUST

MATERIAL	AUSTENITIC 21-4N STEEL
HEAD DIAMETER - INS. (MM)				
L6	1.271/1.281 (32.2835/32.5375)
V8	1.475/1.485 (37.4651/37.7191)
OVERALL LENGTH - INS. (MM)				
L6	4.493/4.513 (114.1226/114.6307)
V8	5.217/ 5.237 (132.5123/133.0203)
STEM DIAMETER - INS. (MM)3410/.3417 (8.6614/8.6792)
STEM CLEARANCE - INS. (MM)				
L60020/.0037 (.0508/.0940)
V80010/.0027 (.0254/.0686)
LIFT - INS. (MM)				
L6338 (8.5852)
V8400 (10.1600)
VALVE CLEARANCE	ZERO

Issued: MAY, 1977

Revised:

HOLDEN 'HZ' FEATURES

SPECIFICATIONS

ENGINE DATA

PRINCIPAL COMPONENTS (CONT'D)

VALVE INLET		
MATERIAL	...	ALLOY STEEL
HEAD DIAMETER - INS. (mm)		
L6	...	1.488/1.498 (37.7955/38.0493)
V8	...	1.755/1.765 (44.5772/44.8312)
OVERALL LENGTH - INS. (mm)		
L6	...	4.495/4.515 (114.1734/114.6315)
V8	...	5.211/5.231 (132.3599/132.8679)
STEM DIAMETER - INS. (mm)3410/.3417 (8.6614/8.6792)
STEM CLEARANCE - INS. (mm)0010/.0027 (.0254/.0686)
LIFT - INS. (mm)		
L6338 (8.5852)
V8400 (10.1600)
VALVE CLEARANCE (HOT) - INS. (mm)		ZERO
VALVE ROCKER ARM TYPE	...	CYLINDRICAL FULCRUM SUPPORTED
RATIO :1		
L6	...	1.50
V8	...	1.60

VALVE SPRING INLET & EXHAUST		
LENGTH AND LOAD - INS. @ LBS. (mm.@ kg.)		
VALVE CLOSED		VALVE OPEN
L6 - 1.513369/75 (38.4031/34)		1.1752166/175 (29.8875/79)
V8 - 1.70276/84 (45.2334/38)		1.252194/206 (31.7288/93)

FREE LENGTH APPROX. - INS. (mm)		
L6	...	1.732 (43.99)
V8	...	2.03 (51.56)
DAMPER FREE LENGTH - INS. (mm)		
L6	...	NONE
V8	...	1.83/1.95 (46.48/49.53)

ENGINE TIMING

FIRING ORDER		
L6	...	1-5-3-6-2-4
V8	...	1-2-7-8-4-5-6-3

ACTUAL VALVE TIMING - DEG. CRANKSHAFT

			EXCLUDING RAMP	INCLUDING RAMP
E A M U I T S O S I R A N N S	L6	INLET - OPENS (BTC)	29	77
		- CLOSSES (ABC)	59	107
		DURATION	268	364
	EXHAUST	- OPENS (BBC)	64	112
		- CLOSSES (ATC)	24	72
		DURATION	268	364
OVERLAP	53	149		
A L L O T H E R	L6	INLET - OPENS (BTC)	15	35
		- CLOSSES (ABC)	45	75
		DURATION	240	290
	EXHAUST	- OPENS (BBC)	50	70
		- CLOSSES (ATC)	10	40
		DURATION	240	290
OVERLAP	25	75		
E M I S S I O N S	V8	INLET - OPENS (BTC)	14	32
		- CLOSSES (ABC)	60	86
		DURATION	254	298
	4.2	EXHAUST - OPENS (BBC)	42	60
		- CLOSSES (ATC)	32	58
		DURATION	254	298
OVERLAP	46	90		
E X P O R T	V8	INLET - OPENS (BTC)	27	43
		- CLOSSES (ABC)	63	91
		DURATION	270	314
	4.2	EXHAUST - OPENS (BBC)	71	87
		- CLOSSES (ATC)	19	47
		DURATION	270	314
OVERLAP	46	90		
V8	INLET	- OPENS (BTC)	28	38
		- CLOSSES (ABC)	72	92
		DURATION	280	310
	5.0	EXHAUST - OPENS (BBC)	78	88
		- CLOSSES (ATC)	30	52
		DURATION	288	320
OVERLAP	58	90		

LUBRICATION SYSTEM

METHOD OF LUBRICATION

MAIN BEARINGS	...	PRESSURE
CON ROD BIG ENDS	...	PRESSURE
CON ROD PISTON PINS		
L6, V8	...	OIL SCEAPED FROM BORE WALLS
CYLINDER WALLS		
L6, V8	...	SPLASH

Issued: MAY, 1977 Revised: JUNE, 1977

HOLDEN 'H2' FEATURES

X

SPECIFICATIONS

ENGINE DATA

PRINCIPAL COMPONENTS (CONT'D)

LUBRICATION SYSTEM (CONT'D)

METHOD OF LUBRICATION (CONT'D)

CAMSHAFT BEARINGS	PRESSURE
VALVE LIFTERS/ TAPPETS	PRESSURE
TIMING GEAR/ CHAIN	NOZZLE SPRAYED
OVERHEAD VALVE GEAR	PRESSURE

OIL PAN

CAPACITY - IMP. PINTS (LITRES) LESS FILTER			
L6	6.0 (3.4)
V8	7.0 (4.0)

OIL FILTER

TYPE	FULL FLOW DISPOSABLE CANISTER
FEATURES	NON RETURN CHECK VALVE
CAPACITY - IMP. PINTS (LITRES)	1.5 (.9)

OIL PUMP

TYPE	GEAR
FEATURES	BY-PASS VALVE UNSEATED UNDER 9-11 PSI (62/76 KPA) PRESSURE DIFFERENTIAL

ENGINE OIL PRESSURE - PSI (KPA)

L6	15MIN (103) @ 500RPM 30/45 (207/310) @ 1500 RPM
V8	7 MIN (48) @ 500 RPM 40/60 (275/414) @ 2000 RPM

OIL PRESSURE WARNING - SWITCH SETTING WITH CONTACTS OPEN - PSI (KPA)

3/5 (21/34)

SENDER OPERATING RANGE - PSI (KPA)

0-80 (0-550)

LUBRICANT GRADES AND TEMPERATURE - °F (°C)

LOWEST ANTICIPATED TEMPERATURE DURING THE INTERVAL IN WHICH THE OIL WILL REMAIN IN THE CRANKCASE

+20°F (-7°C) AND BELOW SAE 5W, SAE 5W-10, SAE 5W-20

0°F (-18°C) TO 60°F (16°C) SAE 10W, SAE 10W-20, SAE 10W-30, SAE 10W-40.

+32°F (0°C) AND ABOVE. SAE DUAL 20/30, SAE 20W, SAE 10W-30, SAE 10W-40.

FUEL SYSTEM

AIR CLEANER AND SILENCER

TYPE	FLUID TREATED PAPER ELEMENT
------	----	----	----	-----------------------------

FUEL PUMP

TYPE	MECHANICAL (DIAPHRAGM)
OUTPUT PRESSURE - PSI (KPA) @ RPM				
L6	3.0/4.0 (21/27) @ 3600
V8	4.5/5.7 (31/39)

INTAKE MANIFOLD

L6	EXHAUST HEATED
V8	EXHAUST HEATED 8 PORT DOUBLE DECK

CARBURETOR

MAKE	L6, V8 - 4.2	BENDIX STROMBERG
	V8 - 5.0	ROCHESTER
MODEL	L6	BXUV-3
	V8 - 4.2	WW
	5.0	QUADRAJET 4MV

TYPE

DOWNDRAFT

NUMBER CARBURETORS & BARRELS

L6	ONE - 1 BARREL
V8 - 4.2	ONE - 2 BARREL
5.0	ONE - 4 BARREL

CHOKE CONTROL

L6 MAN. AUTO. TRANS.	MANUAL
V8 MAN. AUTO. TRANS.	AUTOMATIC

Issued: MAY, 1977

Revised:

HOLDEN 'HZ' FEATURES

SPECIFICATIONS

ENGINE DATA PRINCIPAL COMPONENTS (CONT'D.....)

LOCAL CARBURETOR SPECIFICATIONS

SPECIFICATION		APPLICATION				
		3300 HC	3300 LC	3300 CHASSIS CAR	4.2	5.0
PART NUMBER	MANUAL	92004609	9946313	9940851	9946985	17057294
	AUTOMATIC	92000034	9946314	9940852	9946986	
CODE	MANUAL	MA	MB	MY	ME	-
	AUTOMATIC	AA	AB	AY	AE	-
VENTURI DIAM.	PRIMARY	31 MM			1.188	1.093
	SECONDARY	-			-	AIR VALVE
THROTTLE BORE	PRIMARY	1 9/16			1.43	1.38
	SECONDARY	-			-	2.25
MAIN METERING JET		MAN 340	AUTO 330	MAN 330	AUTO 320	320
POWER JET		1ST. .020 2ND. .051				-
PUMP DISCHARGE JET		0.70 MM			#71	.026
IDLE TUBE/JET		MAN #64	AUTO #66	#62	#66	.038
METERING ROD	PRIMARY	-				.043C/.026
	SECONDARY	-				CT @ 2.165
*FLOAT LEVEL-INS @ PSI/MM @ kPa		.63/.69 (16.0/17.5) @ 3 (20.7)			.62 INS. (15.7) @ 4 (27)	.60 INS. (15.2) @ 5 (34)

EXPORT CARBURETOR SPECIFICATIONS

SPECIFICATION		APPLICATION			
		2850	3300	4.2	5.0
PART NUMBER	MANUAL	9930585	9930587	9931463	7043283
	AUTOMATIC	9930586	9930588	9931464	7043284
CODE	MANUAL	HO	MP	MR	ZJ
	AUTOMATIC	AO	AP	AR	ZK
VENTURI DIAM.	PRIMARY	1.219		1.188	1.093
	SECONDARY	-		-	AIR VALVE
THROTTLE BORE	PRIMARY	1.44		1.43	1.38
	SECONDARY	-		-	2.25
MAIN METERING JET		370 CC.		.050	MAN.77CC. AUTO.76CC.
POWER JET		2 X #53		1ST: .020 2ND: .064	.050/.026 .045/.026
PUMP DISCHARGE JET		2 X #56		MAN.# 71 AUTO.# 68	.026
IDLE TUBE/JET		#62		#66 #67	.031
METERING ROD	PRIMARY	-		-	7034850 7034845
	SECONDARY	-		-	AN
*FLOAT LEVEL - INS./ PSI/mm/kPa		.63/.69 (16.0/17.5) @ 3 (20.7)		.62 INS. (15.7) @ 4 (27)	.60 INS. (15.2) @ 5 (34)

* = FLOAT LEVEL SPECIFIED FOR RECONDITIONING PURPOSES ONLY. NOT TO BE RESET OR ADJUSTED AT LESS THAN 80000 KM.

= DRILL NO.

Issued: MAY, 1977 Revised: OCTOBER, 1977

HOLDEN 'HIZ' FEATURES

SPECIFICATIONS

ENGINE DATA

PRINCIPAL COMPONENTS (CONT'D)

COOLING SYSTEM

ENGINE COOLING

TYPE LIQUID PRESSURISED SYSTEM WITH FULL LENGTH WATER JACKETS AROUND EACH CYLINDER

DRAIN TYPE

L6 LEFT SIDE BLOCK - REAR
V8 RIGHT AND LEFT - CENTRE

WATER PUMP

CAPACITY - IMP. GALL. (LITRES)/ MIN. @ RPM
L6 40 (182) @ 4400
V8 31 (141) @ 3000

WATER THERMOSTAT

TYPE WAX PELLETT
LOCATION
L6 IN CYLINDER HEAD WATER OUTLET
V8 INLET MANIFOLD WATER CROSSOVER PASSAGE

STARTS TO OPEN DEG. F (C) NOM. - 180 (82) EXPORT
FULL FLOW DEG. F (C) NOM. - 195 (91) EMISSION
- 202 (94)

ENGINE FAN

BLADES NUMBER AND DIAMETER - INS. (MM)
L6 4 - 15.5 (394)
V8 4 - 17.6 (447)
AIRCONDITIONING .. 7 - 18" (457)

WATER PUMP ENGINE SPEED RATIO :1

L6 1.15
V8 1.05
AIRCONDITIONING .. 1.30

FAN BELT - WIDTH X LENGTH - INS. (MM) X PITCH ANGLE

L638 (9.6) x 35.25 (895) x 40°
V8 - 4.238 (9.6) x 43.00 (1092) x 40°
5.038 (9.6) x 43.67 (1109) x 40°

TEMPERATURE WARNING SWITCH SETTING - DEG. F (C)

L6, V8 243 (117)

MAX. GENERATOR OPERATING RANGE DEG. F (C) - 248 (120)

COOLING SYSTEM CAPACITY - IMP. PINTS (LITRES)

L6 15.0 (8.5)
V8 - 4.2 21.0 (12.0)
5.0 20.0 (11.5)

PRESSURE CAP

PSI (KG/CM) - NOMINAL .. 15 (1.05)

ENGINE ELECTRICAL SYSTEM

GENERATOR

MAKE BOSCH OR LUCAS
NON AIRCONDITIONED PART NO. 9930535 OR 2825480
AIRCONDITIONED PART NUMBER. 9930537 OR 5930764

TYPE 12 POLE ALTERNATING CURRENT GENERATOR - STAR WOUND STATOR - DIODE RECTIFIED WITH INTEGRAL TRANSISTOR REGULATOR

OUTPUT RATING - AMPS. & VOLTS

NON AIRCONDITIONED .. 40A - 13.5V
AIRCONDITIONED EQUIPMENT.. 55A - 13.5V

PULLEY PITCH DIA. - INS. (MM)

L6, V8 2.50 (63.5)

SPEED RATIO - GEN. TO CRANK/S. REVS. :1

L6 2.36
V8 2.41

CUT IN SPEED (HOT) @ ERPM

L6 460 OR IDLE
V8 450 OR IDLE

ENGINE SPEED @ MAX. GEN. OUTPUT - RPM

L6 1910
V8 1870

MAX. CONTINUOUS OUTPUT - AMPS.

@ GENERATOR RPM .. 40 OR 55 @ 4500

VOLTAGE REGULATOR

TYPE INTEGRAL TRANSISTOR

VOLTAGE SETTING @ 68F (20C)

14.1/14.5

Issued: 1970, 1971

Revised:

HOLDEN 'HZ' FEATURES

SPECIFICATIONS

ENGINE DATA

PRINCIPAL COMPONENTS (CONT'D)

ENGINE ELECTRICAL SYSTEM (Cont'd...)

STARTER MOTOR

MAKE BOSCH (ALTERNATIVE LUCAS)
 TYPE 4 POLE 4 BRUSH PRE-ENGAGED DRIVE

NUMBER OF TEETH

PINION 9
 FLYWHEEL
 L6 137
 V8 153

STARTER MOTOR TEST DATA

ENGINE MODELS	LOCK TEST CURRENT AMPS @ 7V	LOCK TORQUE LBS/FT. NM	BRUSH TENSION oz. (kg.)
ALL MODELS	510	19 25.8	42/46 (1.19/1.30)

IGNITION COIL

MAKE BOSCH OR LUCAS
 CURRENT DRAW - AMPS
 RUNNING (IDLING) 3.3
 STOPPED 3.7

SPARK PLUGS

MAKE AC
 TYPE & GAP SETTING - INS (mm)
 LOCAL ENGINES (1976 EMISSIONS EQUIPMENT)
 3300 45 T .040 (1)
 4.2 & 5.0 44 T .040 (1)
 EXPORT ENGINES (WITHOUT 1976 EMISSIONS EQUIP)
 2850 44 T .038 (.965)
 3300 45 T .038 (.965)
 4.2 & 5.0 44 T .038 (.965)

ENGINE	CENTRIFUGAL ADVANCE DEGREES @ ENG. RPM			VACUUM ADVANCE DEGREES AT KPa		APPROX. BREAKER GAP INS. (mm)	CAM. ANGLE DEGREES	CONDENSOR CAPACITY MICROFARAD
	START	INTERMEDIATE	FULL	START	FULL			

LOCAL ENGINES (WITH 1976 EMISSIONS EQUIPMENT)

3300 HC M	0/4.0 @ 1000	13/17 @ 1700	23/27 @ 4400	0 @ 13/21	11 @ 37 TO 15 @ 30	.018 (.45)	30/34	.15/.20
3300 LC M	0/2.0 @ 1100	22/26 @ 2000	33/37 @ 4400					
3300 HC A	0/2 @ 1000	14/18 @ 2000	23/27 @ 4400					
3300 CHASSIS CAB	0/1.4 @ 1200	9.4/13.4 @ 2000	26/30 @ 4400	5/9 0 @ (127/229)	10 @ 110 TO 14 @ 96	.016 (.41)	26/30	
4.2	0/2 @ 750	16/20 @ 2500	27/31 @ 4400	0 @ 15/25	14 @ 40 TO 18 @ 35			
5.0			22/26 @ 4400	0 @ 20/30	14 @ 47 TO 18 @ 37			

EXPORT ENGINES (LESS 1976 EMISSIONS EQUIPMENT)

2850	0/2 @ 600	20/24 @ 2000	31/35 @ 4600	5/7 0 @ (127/178)	11 @ 69 TO 15 @ 59	.022 (.56)	30/35	.15/.20
3300					9 @ 76 TO 13 @ 62			
4.2	0/2 @ 500	17/21 @ 2000	28/32 @ 4400	4/8 0 @ (152/203)	14 @ 96 TO 18 @ 83	.014 (.36)	30/34	
5.0					15/19 @ 2000			

TIMING SPARK ADVANCE INITIAL SETTING DEG. BTDC/RPM
 LOCAL ENGINES (WITH 1976 EMISSIONS EQUIPMENT)
 3300 6° BELOW 900
 3300 CHASSIS CAB 3° BELOW 900
 4.2 & 5.0 12° at 1350

EXPORT ENGINES (LESS 1976 EMISSIONS EQUIPMENT)

L6 8° @ 800
 V8 4.2 LC 8° @ 800
 4.2 HC MAN. 10° @ 800
 4.2 HC AUTO. 12° @ 800
 5.0 6° @ 800

TIMING MARK

L6, V8 - TDC LONG MARK ON TIMING COVER AND MARK ON HARMONIC BALANCER PULLEY

Issued: MAY, 1977 Revised: JULY, 1978

HOLDEN 'HIZ' FEATURES

SPECIFICATIONS

CLUTCH AND TRANSMISSION

CLUTCH AND CONTROLS

CLUTCH					
TYPE	SINGLE DRY PLATE
SPRINGS					
TYPE	BELLVILLE DIAPHRAGM
LINING MATERIAL	ASBESTOS FABRIC

DRIVEN PLATE SPECIFICATIONS

ENGINE	OUTSIDE DIA.		INSIDE DIA.		THICKNESS		AREA GROSS (2 LININGS)	
	INS.	MM.	INS.	MM.	INS.	MM.	SQ. INS.	SQ. CM.
6 CYL.	8.62	218.95	6.12	155.45	.298	7.57	57.88	373.4
4.2 V8	9.50	241.30	6.00	152.40			85.22	549.80
5.0 V8	10.00	254.00	6.50	165.10			90.71	581.71

CLUTCH OPERATION SYSTEM

.. .. . CABLE

BEARING THROWOUT

TYPE SINGLE ROW BALL

MANUAL TRANSMISSION

TRANSMISSION TYPE ALL SYNCHROMESH

SHIFT LOCATION

3 SPEED COLUMN

4 SPEED FLOOR

CENTRE DISTANCE INS.(MM) 2.75 (69.8)

GEAR RATIOS :1

TRANSMISSION	OPTION CODE	FIRST	SECOND	THIRD	FOURTH	REVERSE
3 SPEED	M15	3.07	1.68	1.00	-	3.59
4 SPEED	M20	3.05	2.13	1.51	1.00	3.05
	M21	2.54	1.83	1.38	1.00	2.54
	M22	3.74	2.68	1.68	1.00	3.72

OIL CAPACITY AND OIL TYPE

3 AND 4 SPEED 3.4 PINTS (2.0 LITRE) - HN 1046

Issued: MAY, 1977

Revised:

HOLDEN 'HZ' FEATURES

SPECIFICATIONS

AUTOMATIC TRANSMISSION

GENERAL DATA

TYPE

AUTOMATIC HYDRAULIC TORQUE CONVERTOR WITH COMPOUND PLANETARY GEAR SYSTEM - THREE FORWARD SPEEDS AND ONE REVERSE

GEAR RATIO

TRANSMISSION	DRIVE	SECOND	LOW	REVERSE
TRIMATIC	1.00	1.46	2.31	1.85
TURBO HYDRAMATIC 400	1.00	1.48	2.48	2.08

DOWNSHIFT SWITCH SOLENOID OPERATED

TORQUE MULTIPLICATION :1 (CONT'D)

COOLING METHOD WATER

TURBO HYDRAMATIC 400 - 5.0 V8

CONVERTOR ASSEMBLY

LOW 4.96

STALL RATIO :1

REVERSE 4.16

TRIMATIC

LUBRICANT

L6

.. .. . 2.40

V8 4.2

.. .. . 2.20

5.0

.. .. . 2.00

TYPE

■ DEXRON TYPE II

DIAMETER NOMINAL - INS. (MM)

CAPACITY IMP. PINTS (LITRES)

L6

.. .. . 10.00 (254)

TRIMATIC

V8

.. .. . 11.75 (298)

DRY

L6 10.7 (6.1)

TORQUE MULTIPLICATION :1

V8 15.3 (8.7)

TRIMATIC

REFILL 3.0 (1.7)

LOW

L6

.. .. . 5.54

TURBO HYDRAMATIC

V8 4.2

.. .. . 5.08

DRY

.. .. . 18.3 (10.4)

REVERSE

L6

.. .. . 4.44

REFILL

.. .. . 6.5 (3.7)

V8 4.2

.. .. . 4.07

TRANSMISSION OUTPUT SPEEDS - RPM

(TO CALCULATE SHIFT SPEEDS IN MPH)

ENGINE	UPSHIFTS				DOWNSHIFTS			
	CLOSED	THROTTLE	FULL	THROTTLE	CLOSED	THROTTLE	FULL	THROTTLE
	1 - 2	2 - 3	1 - 2	2 - 3	2 - 1	3 - 2	3 - 2	2 - 1
L6	535	752	1917	2972	419	634	2600	1510
V8 - 4.2	535	752	1917	2972	419	634	2600	1480
V8 - 5.0	488	895	1670	2770	286	488	2444	815

SHIFT SPEED IN MPH = $\frac{\text{TRANSMISSION OUTPUT SPEED IN RPM}}{\text{ENGINE RPM/MPH}}$

EXAMPLE : SPEED IN MPH FOR 1-2 FULL THROTTLE UPSHIFT FOR A POWER TRAIN COMBINATION OF L6 ENGINE, ER72514 TYRES AND 3.36:1 REAR AXLE.

TRANSMISSION OUTPUT SPEED = 1917 RPM

ENGINE RPM/MPH = (REFER PAGE F - 29) 45.4

= $\frac{1917}{45.4}$ = 42.22 MPH.

THEREFORE 1-2 FULL THROTTLE UPSHIFT OCCURS AT 42 MPH APPROXIMATELY

Issued: MAY, 1977 ■ Revised: AUGUST, 1977

HOLDEN 'HIZ' FEATURES

SPECIFICATIONS

EXHAUST SYSTEM AND FUEL TANK SPECIFICATIONS

EXHAUST SYSTEM:

DESCRIPTION:	
L6 Engines	Single front and rear exhaust pipe with muffler and tail pipe.
V8 Engine except GTS & Production Option N10	Separate front exhaust pipes from each side of engine with cross-over into single rear pipe and into muffler with single tailpipe.
GTS & Production Option N10 (Standard GTS)	Separate front exhaust pipes from each side of engine with balance tube into individual mufflers with single tailpipes.
Statesman	Same as GTS with larger mufflers and separate additional resonators. Chrome extensions are fitted to the tail pipes.

MUFFLER:

All models	Reverse flow with resonant chamber incorporated. Double skin shell and asbestos insulator.
------------	--

EXHAUST PIPES:

Type	Steel Tubing
Outside Diameter - Ins./(mm)	
L6 engines	1.875 / 47.6
V8 engines	2.000 / 50.8
Wall thickness - Ins./(mm)	.06 / 1.5

TAILPIPES:

Type	Steel Tubing
Outside Diameter - Ins./(mm)	
L6 engines	1.625 / 41.2
V8 engines	2.000 / 50.8

MOUNTING

	2 Points plus attachment to manifold.
--	---------------------------------------

FUEL TANK:

Type	Two pressings seam welded forming a basic rectangular shape incorporating evaporative emission fuel vapour pipes
Location:	
All except Commercial Vehicles	Externally strap mounted under rear compartment floor.
Commercial Vehicles	RH chassis forward of rear axle.
Capacity - Imp. gals/litres	
Passenger Vehicles	16.5/ 75.0
Commercial Vehicles	15.5/ 70.4
Filler Location	
Sedans	Behind hinged rear licence plate.
Station Sedans, Panel Vans, Utilities	Flush fitting circular. Fuel filler cap in RH side body rear quarter panel.
Chassis Cab	Circular fuel filler cap on neck of fuel tank.
Filter	
Primary	Primary saran filter for initial dirt and water infiltration in fuel tank on riser pipe combined with fuel gauge.
Secondary	
L6 Engines	In fuel pump
5.0 V8 Engines	In carburetor
4.2 V8 Engines	On fuel pipe between fuel pump and carburettor.

Issued: MAY, 1977

Revised:

HOLDEN 'HZ' FEATURES

SPECIFICATIONS

STEERING

TURNING CIRCLE - FEET (METRES)

WHEELBASE - INS.(CMS)	CURB TO CURB **	WALL TO WALL **
111.0 (282)	39.7 (12.1)	42.1 (12.8)
114.0 (289.5)	40.5 (12.3)	43.0 (13.1)
120.4 (306)	42.0 (12.8)	44.0 (13.4)

** CALCULATED

DESCRIPTION
ENERGY ABSORBING STEERING COLUMN WITH UPPER INTERMEDIATE SHAFT COUPLING AND FLEXIBLE COUPLING AT RECIRCULATING BALL TYPE STEERING BOX.					
POWER ASSISTANCE	STANDARD ON STATESMAN DEVILLE AND STATESMAN CAPRICE P/O N40 ON ALL OTHER MODELS EXCEPT CHASSIS AND CAB.
OVERALL STEERING RATIO					
MANUAL	25.0:1
STATESMAN & P/O N40 POWER STEERING	18.1:1 ON CENTRE TO 11.7:1 AT LOCK
MANUAL STEERING GEAR TYPE	RECIRCULATING BALL
LUBRICATION TYPE	LIFE LUBRICATED AT ASSEMBLY
CAPACITY - FLUID OZS. (ML)	9.0 (256)
SPECIFICATION	GMH CG-1
STEERING COLUMN TYPE	ENERGY ABSORBING
DESCRIPTION	LOWER PORTION OF COLUMN MESHED AND INCORPORATES A STEERING SHAFT OF THREE PIECE DESIGN AND A TWO SECTION FABRICATED SHIFTER TUBE.
STEERING WHEEL DIAMETER INS. (MM) AND TYPE ALL MODELS EXCEPT GTS	16 (406) X 15.0 (381) TWO SPOKE DISHED - OVAL
GTS	15.5 (394) THREE SPOKE DISHED - CIRCULAR
POWER STEERING TYPE	INTEGRAL VARIABLE RATIO GEAR - ROTARY TYPE CONTROL VALVE
PUMP - MAKE AND TYPE	SAGINAW - CONSTANT DISPLACEMENT TYPE
DRIVE	PULLEY ON CRANKSHAFT
LUBRICATION TYPE	AUTOMATIC TRANSMISSION OIL (9985158)
NUMBER TURNS LOCK TO LOCK					
MANUAL	5.2
POWER	2.6
LINKAGE TYPE	PARALLELOGRAM

Issued: MAY, 1977

Revised: JUNE, 1977

HOLDEN 'HZ' FEATURES

SPECIFICATIONS

WHEELS AND TYRES - SPECIFICATIONS

STANDARD TYRE AVAILABILITY

SIZE	TYRE CONSTRUCTION		LOAD RATING	MODEL
	TYPE	CORD MATERIAL		
185SR14	RADIAL	TEXTILE	4 P/R	10 cwt. DERATED PANEL VAN & UTILITY 500 kg.
195SR14				MAX. RATED PANEL VAN & UTILITY KINGSWOOD (A9K)
195R14LT		STEEL	8 P/R	CHASSIS CAB
ER78SR14			4 P/R	STATION WAGONS, SHORT WHEELBASE SEDANS
ER70H14			6 P/R	MONARO GTS AND 10 cwt. DERATED SANDMAN 500 kg.
FR78S14			4 P/R	STATESMAN, MAX. RATED SANDMAN

WHEELS

Type

All except GTS & Chassis Cab	Short spoke steel disc. Rim incorporates safety hump on inner and out flanges.
Chassis & Cab	As above but heavy duty construction.
Monaro GTS & P/O N66	5 spoke pressed steel slotted rally wheel. Rim incorporates safety hump on inner and outer flanges.
PE1 Wheel Option	Short spoke disc. Rim incorporates safety hump on inner and outer flanges. A honeycomb pattern polyurethane insert is permanently moulded to the wheel.
N71 Wheel Option	72 spoke triple laced chrome wire wheel with 5 bolt flange attachment. Rim incorporates safety hump on inner and outer flanges.

Attachment to Hub	5 bolts 7/16 20 UNF. - 2A thread
Bolt Pitch Circle dia. - ins. (mm.)	4.75 (120.7)
Rim Size	
All except P/O PE1	14 X 6.00JJ
P/O PE1	14 X 7.00JJ
(Note 1) Offset - ins. (mm.)	
■ All except Chassis Cab	.50 (12.7)
■ Chassis Cab	.63 (16.0)
P/O PE1	.34 (8.6)
P/O N71	.39 (10)

TYRES

Spare Wheel Location	
Sedans (except Statesman)	Horizontally mounted to rear compartment floor. Obliquely mounted on forward section of luggage compartment.
Station Sedans	Mounted horizontally below load compartment floor.
Commercials	Mounted to chassis at rear on drop cradle.
Inflation Pressures recommended:	
Refer to Tyre placard located inside instrument panel compartment door.	

NOTE 1. Front and Rear Vehicle Track should be adjusted when optional Wheels are fitted. Refer Sheets F - 7 & F - 9 for standard dimensions.

Issued: MAY, 1977 ■ Revised: AUGUST, 1977

HOLDEN 'HZ' FEATURES

SPECIFICATIONS

ELECTRICAL

BATTERY

MAKE	LUCAS, CHLORIDE.
TYPE	POLYPROPYLENE CASE SYNTHETIC MATERIAL SEPARATORS.
NUMBER OF PLATES PER CELL	
L6, V8	7
RATED VOLTAGE	12
CAPACITY @ 20 A/H RATING	
7 PLATE	L6 - 48 / V8 - 61

HEADLAMPS

TYPE	SAE STANDARD ROUND
PANEL VAN	SINGLE 7" SEALED BEAM
UTILITY K/WOOD (A9K)	
KINGSWOOD SL	SINGLE 7" QUARTZ HALOGEN SEMI-SEALED BEAM
CHASSIS CAB	SINGLE 7" SEALED BEAM WITH PARK LAMP
GTS, SANDMAN	DUAL 5 3/4" QUARTZ HALOGEN SEMI-SEALED WITH HI-INTENSITY HI-BEAM
PREMIER, STATESMAN	DUAL 5 3/4" QUARTZ HALOGEN SEMI-SEALED BEAM

BULBS

BULBS	GMH NO	BASE TYPE	RATING	TRADE NUMBER
FRONT PARK INSTRUMENT ILLUMINATION GLOVE BOX BRAKE WARNING - GTS PARK BRAKE WARNING - GTS AUTO. TRANS. SELECTOR (COLUMN) TEMPERATURE TELL-TALE	9421330	10 mm. WEDGE BASE	2CP	194
OIL PRESSURE & GEN TELL-TALE HI-BEAM ASH-TRAY & CIGAR LIGHTER ILLUMINATION BRAKE WARNING EXCEPT GTS PARK BRAKE WARNING EXCEPT GTS	SP 2103	5 mm. WEDGE BASE	2CP	-
FRONT TURN SIGNAL REAR TURN SIGNAL & BACK/UP	9417866	STANDARD PARALLEL PIN	32CP	1156
FOOTWELL	SP 1467	MINI PARALLEL PIN	6 WATT	989
DOME LAMP	9414045 OR 9422525	FESTOON	12CP	211 211/1
REAR QUARTER CORNER DOOR COURTESY LAMPS	SP 1932	FESTOON	5 WATT	-
REAR QUARTER READING LAMP ROOF MOUNTED READING LAMPS	455136	STANDARD PARALLEL PIN	15CP	-
LUGGAGE COMPARTMENT	455490	STANDARD PARALLEL PIN	15CP	1003
STOP/TAIL	9417867	STANDARD OFFSET PIN	4-32CP	H 57
LICENCE PLATE SIDE MARKERS HEATER & AIRCONDITIONING CONTROLS AUTO. TRANS. CONSOLE SELECTOR	9417863	STANDARD PARALLEL PIN	2CP	1895
HEADLAMP - 7" PANEL VAN, UTILITY, TUNGSOL KINGSWOOD (A9K) - 1 GE	7434806		75/50	
CHASSIS CAB - TUNGSOL GE	2823661			
KINGSWOOD 'SL' P/O TT5	9939957	DUPLO	60/55	
KINGSWOOD 'SL' P/O TT5	9939957	DUPLO	60/55	
HEADLAMPS 5.75 INNER HI BEAM HI INTENSITY STD.	9946970 9945933	DUPLO	55 W	
OUTER LO BEAM ALL	9946097			

FUSE POSITION	CIRCUIT	FUSE NO. & CAPACITY
1-2	INSTRUMENT & CONTROL ILLUMINATION.	3 AMP.
3-4	TRAILER CIRCUIT.	15 AMP.
5-6	HORN, HORN RELAY, CLOCK, PWR. ANT. MTR.	15 AMP.
7-8	FRONT PARK, TAIL, LICENCE PLATE, GLOVE-BOX, RR. COMPARTMENT, DOME LAMP, FUSE 1-2, FOOTWELL ILLUMINATION.	25 AMP.
9-10	SIDE WINDOWS, DOOR LOCKS, POWER ENDGATE.	15 AMP.
11-12	BACK-UP, ANTI DIES. SOLENOID, DIST. ADV. SOLENOID, INSTRUMENTS, DETENT SOLENOID, POWER WINDOW RELAY.	15 AMP.
13-14	HEATER FAN, WIPER DWELL CONTROL, AIR-CONDITIONING FAN, AIRCONDITIONING CLUTCH.	15 AMP.
15-16	TURN SIGNAL LAMPS, WIPER MOTOR, POWER ANTENNA MOTOR & RELAY, WASHER PUMP, FLASHER UNIT.	15 AMP.
17-18	RADIO/ STEREO.	3 AMP.
19-20	CIGAR LIGHTER, HEATED WINDOW, HEATED WINDOW PILOT LAMP.	25 AMP.
20-21	HEADLAMP FLASH STOP LAMPS.	25 AMP.
22-23	BRAKE ANTI-LOCK SYSTEM.	15 AMP.
IN-LINE FUSE	AUXILIARY DRIVING LIGHTS, AIRCONDITIONING AUXILIARY COOLING FAN, AIRCONDITIONING FAN (HI) ELECTRIC DECK LID LOCK.	15 AMP.
CIRCUIT BREAKER	HEADLAMPS IN SWITCH, AIRCONDITIONING AUXILIARY COOLING FAN, AIRCONDITIONING HI-BLOWER SPEED.	

HORNS

BELMONT, KINGSWOOD, MONARO, CHASSIS & CAB ... SINGLE
 PREMIER, GTS, STATESMAN ... DUAL -
 LOW & HIGH NOTE

Issued: MAY, 1977

Revised: AUGUST, 1977

HOLDEN 'HZ' FEATURES

SPECIFICATIONS

GLASS AREAS

MODELS	GLASS	TYPE	DAYLIGHT OPENING		THICKNESS	
			SQ. IN.	SQ. CM.	mm.	
HOLDEN COMMERCIAL KINGSWOOD AQK & ALL EXCEPT STATESMAN CAPRICE	WINDSHIELD	CURVED HEAT TREATED SAFETY PLATE WITH MODIFIED ZONE.	1388	8955	5.0 ± 0.2	
STATESMAN CAPRICE ALL EXCEPT KINGSWOOD AQK & HOLDEN COMM.		LAMINATED WITH TINTED UPPER SHADED BAND			6.0 + 0.3 - 0.6	
SEDANS EXCEPT STATESMAN	REAR WINDOW	HEAT TREATED SAFETY SHEET	1136	7328	5.0 ± 0.2	
HOLDEN SEDANS STATESMAN		HEAT TREATED SAFETY SHEET ELECTRICALLY HEATED (TINTED CAPRICE) EXCEPT KINGSWOOD	1037	6690	4.0 ± 0.2	
UTILITY, CHASSIS & CAB	END GATE	HEAT TREATED SAFETY SHEET	544	3510	5.0 ± 0.2	
STATION SEDAN			664	4283		
PANEL VAN			466	3009		
ALL			780	5032		
SEDANS, HOLDEN SEDANS	FRONT DOOR (2 SIDES)	HEAT TREATED SAFETY SHEET	569	3671	4.0 ± 0.2	
STATION SEDANS	REAR DOOR SLIDING (2 SIDES)		578	3729		
SEDANS			569	3671		
HOLDEN SHORT WHEELBASE SEDANS			165	1066		
STATION SEDAN	REAR DOOR FIXED (2 SIDES)		219	1413		
STATESMAN			219	1413		
STATION SEDAN	REAR QUARTER		990	6387		5.0 ± 0.2

TOTAL DAYLIGHT OPENING - SQ. IN. (sq. cm.)

HOLDEN SHORT WHEELBASE SEDANS	3993	4037	(26045) 25761
STATESMAN	4622	2993	(23761) → BE ADVISED
STATION SEDAN	4622		(29819)
COUPE UTILITY & CHASSIS CAB	2712		(17497)
PANEL VAN	2634		(16993)

STATESMAN CAPRICE

TINTED UPPER SHADE BAND WINDSCREEN, TINTED SIDE WINDOWS, & TINTED HEATED REAR SCREEN.

4037
3993
044

Issued: MAY, 1977 Revised:

HOLDEN 'HZ' FEATURES

SPECIFICATIONS

SERIAL NUMBERS IDENTIFICATION AND LOCATION

ENGINE SERIAL NUMBER

HOLDEN ENGINE - L6

HOLDEN ENGINE - V8

LOCATION

L6 - ON PAD ABOVE ENGINE MOUNTING BOSSES
RIGHT HAND SIDE OF ENGINE.

V8 - ON PAD AT TOP FRONT LEFT SIDE OF
CYLINDER CASE.

ASSIGNMENT OF SERIAL NUMBERS

THE ENGINE SERIAL NUMBER PREFIX CONSISTS OF A TWO LETTER CODE. *THE FIRST LETTER RELATES TO* 'HX' ENGINES RETAIN 'HOLDEN' EXTERNAL FEATURES, *COMMON TO AN ENGINE THAT WILL FIT A PARTICULAR MODEL SERIES,* I.E. OIL PAN SHAPE, ENGINE MOUNTING POINTS, ETC. *THEREFORE, CODE LETTER 'Q' WILL CONTINUE AS FIRST LETTER* OF 'HX' ENGINE CODES. SECOND CODE LETTER INDICATES ENGINE CHARACTERISTICS AND IS ALSO UNCHANGED FROM PREVIOUS MODEL SERIES.

RUNNING NUMBERS RUNS
THE ENGINE SERIAL NUMBER STARTS AT 1001 AND RUNS IN CONTINUOUS NUMERICAL SEQUENCE *BETWEEN 1001 & 999999* REGARDLESS OF ENGINE SIZE. ENGINE SIZE DESIGNATIONS ARE :-

<u>L6 ENGINE</u>		<u>V8 ENGINE</u>	
173 LC (2850)	QE	253 LC (4.2)	QS
173 HC (2850)	QD	253 MC (4.2)	WR
<i>3-3LC</i> 202 LC (3300)	WM	300 MC (5.0)	WT
<i>3-34C</i> 202 HC (3300)	WL		

EXAMPLE :-

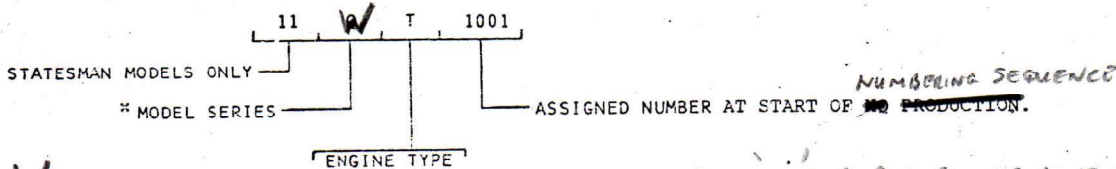

W REFERS TO ENGINES WITH EXTERNAL FEATURES SAME AS HQ. *TO FIT W CAR BODY CHASSIS CONFIGURATION*

VEHICLE SERIAL NUMBER

LOCATION: STAMPED ON FRAME RIGHT HAND SIDE FRONT, IN ENGINE COMPARTMENT.

CODE: VEHICLE SERIAL NUMBER AT EACH BODY ASSEMBLY PLANT EXCEPT DANDENONG, STARTS AT 00001 AND IS PREFIXED BY MODEL SERIES AND SUFFIXED BY A PLANT LETTER WHERE THE BODY IS BUILT. DANDENONG COMMENCES AT 00021*

EXAMPLE :-

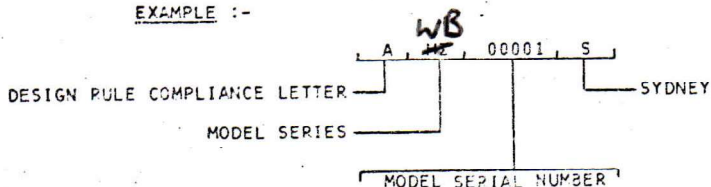

ALPHA CODE LETTER DENOTES COMPLIANCE WITH SAFETY DESIGN RULE.

LETTER STARTS AT 'A' AND ADVANCE TO 'B', 'C' ETC. WITH INTRODUCTION OF ADDITIONAL DESIGN RULES.

* FIRST 20 NUMBERS ARE RESERVED FOR PRE-TEST VEHICLES.

Issued: 2A7, 1977

Revised:

HOLDEN 'HZ' FEATURES

SPECIFICATIONS

SERIAL NUMBERS IDENTIFICATION AND LOCATION (CONTINUED)

BODY IDENTIFICATION PLATE

LOCATION : ATTACHED TO TOP LEDGE OF SHROUD PANEL - LEFT SIDE - UNDER ENGINE HOOD

EXAMPLE :-

37208 N
 BODY SERIAL NUMBER ASSEMBLY PLANT

ADDITIONAL INFORMATION ON PLATE :- MODEL, TRIM, PAINT, ENGINE, TRANSMISSION AND REAR AXLE NUMBERS. PRODUCTION OPTION NUMBERS FOR ENGINE, TRANSMISSION AND REAR AXLE TO BE STAMPED ON WHEN OPTION/S IS/ARE EXERCISED OVER STANDARD POWER TRAIN COMBINATION.

V.I.N. PLATE

LOCATION : ATTACHED TO TOP LEDGE OF SHROUD PANEL - RIGHT SIDE - UNDER ENGINE HOOD

EXAMPLE :-

8 N 69 L D J5 00025 B

GMH DESIGNATION SERIES CODE
 MODEL CODE VEHICLE SERIAL NUMBER
 BODY STYLE ASSEMBLY PLANT CODES
 ENGINE IDENTIFICATION
 MODEL YEAR H1 THRU H4 - BRISBANE
 F - 1976 J 1979 H5 THRU H9 - SYDNEY
 G - 1977 K 1980 J1 THRU J9 - DANDENONG
 H - 1978 L 1980 L1 THRU L5 - ADELAIDE

V.I.N. CODES

MODEL	MODEL IDENTIFICATION	V.I.N. CODE
HOLDEN CHASSIS & CAB	8WM60	8M60
HOLDEN PANEL VAN	8WM70	8M70
HOLDEN UTILITY	8WM80	8M80
KINGSWOOD SL SEDAN	8WM69	8M69
KINGSWOOD SL STATION WAGON	8WN35	8N35
KINGSWOOD PANEL VAN	8WN70	8N70
KINGSWOOD UTILITY	8WN80	8N80
PREMIER SEDAN	8WP69	8P69
PREMIER STATION WAGON	8WP35	8P35
GTS SEDAN	8WQ69	8Q69
STATESMAN DEVILLE	8WS99	8S99
STATESMAN CAPRICE	8WT99	8T99
(OPTIONAL MODELS - BASED ON REGULAR MODELS LISTED ABOVE)		
KINGSWOOD SEDAN	8WN69	8N69
KINGSWOOD SEDAN	8WN35	8N35
SANDMAN PANEL VAN	8WM70	8M70
SANDMAN UTILITY	8WM80	8M80

SAFETY COMPLIANCE PLATE (EXCEPT EXPORT VEHICLES)

LOCATION : ATTACHED TO TOP LEDGE OF SHROUD PANEL - RIGHT SIDE - UNDER ENGINE HOOD

PLATE STAMPED WITH THE FOLLOWING INFORMATION :-

AUSTRALIAN DESIGN RULE NUMBERS	VEHICLE SERIAL NUMBER
VEHICLE MAKE - HOLDEN OR STATESMAN	GROSS VEHICLE WEIGHT IN KG'S (COMMERCIALS ONLY)
VEHICLE MODEL NAME AND STYLE	SEATING CAPACITY OF VEHICLE
MONTH AND YEAR OF MANUFACTURE	

FOR EXPORT COMMERCIAL VEHICLES A G.V.W. PLATE IS FITTED IN THIS LOCATION.

* ASSEMBLY PLANT CODES

S - SYDNEY M - MELBOURNE A - ADELAIDE B - BRISBANE

Issued: MAY, 1977 Revised: OCTOBER, 1977

HOLDEN 'HZ' FEATURES

SPECIFICATIONS

VEHICLE WEIGHTS

LBS.
kg's.
NOMINAL.

MODEL	TARE kg's ONLY	SHIPPING TOTAL	CURB			MAXIMUM LOADED VEHICLE WEIGHT *				
			TOTAL	FRONT	REAR	TOTAL	FRONT	REAR AXLE ENCRG.	SALES	
SEDAN										
KINGSWOOD (A9K)	1313	2879 1306	3001 1361	1581 717	1420 644				2300 1043	
KINGSWOOD 'SL' ¹⁰⁶⁹	1321	2897 1314	3018 1369	1594 723	1424 646				2300 1043	
PREMIER	1362	2987 1355	3109 1410	1614 732	1495 678				2300 1043	
CTS	1452	3186 1445	3307 1500	1770 803	1537 697				2300 1043	
STATESMAN DEVILLE ⁸¹⁹	1550	3402 1543	3523 1598	1867 847	1656 751				2400 1088	
STATESMAN										
STATESMAN CAPRICE ⁷¹⁹	1647	3615 1640	3737 1695	2028 920	1709 775				2400 1088	
STATION WAGON										
KINGSWOOD (A9K)	1388	3044 1331	3166 1423	1568 711	1598 725				2600 1180	
KINGSWOOD 'SL' ¹⁰³⁵	1397	3064 1390	3186 1445	1581 717	1605 728				2600 1180	
PREMIER	1420	3115 1413	3235 1468	1609 730	1627 738				2600 1180	
PANEL VAN										
HOLDEN	1384	3036 1377	3150 1429	1607 729	1543 700	4752 2155	1881 853	2871 1302	2900 1315	
KINGSWOOD	1395	3060 1388	3175 1440	1623 736	1552 704	4752 2155	1881 853	2871 1302	2900 1315	
UTILITY										
HOLDEN	1321	2897 1314	3011 1356	1629 739	1382 627	4752 2155	1881 853	2871 1302	2900 1315	
KINGSWOOD	1331	2919 1324	3034 1376	1634 741	1400 635	4752 2155	1881 853	2871 1302	2900 1315	
CHASSIS & CAB										
HOLDEN	1242	2723 1235	2837 1297	1697 770	1140 517	5733 2650	MIN. 1669 757	MAX. 2205 1000	3951 1792	3900 1700

INCLUDES PASSENGERS, LUGGAGE & WEIGHT OF MAJOR (+5 LB.) OPTIONS WITH STANDARD ENGINE TYPE AND TYRES.
THESE LOADS CAN ONLY BE USED INDIVIDUALLY AS PART OF THE GVW.

SALES REAR AXLE RATING

THIS IS AN ARBITRARY FIGURE FOR USE BY SALES DEPARTMENT. IT IS AN AVERAGE GROUPING OF ENGINEERING AXLE WEIGHTS OF CHOSEN VEHICLE TYPES AND IS SUBJECT TO MUTUAL SALES AND ENGINEERING DEPARTMENT AGREEMENT.

TARE WEIGHT:

THIS WEIGHT IS USED BY GOVERNMENT DEPARTMENTS FOR REGISTRATION. IT IS CURB LESS FUEL +2 GALLONS (DELIVERY WEIGHT).

BALANCE TO BE ADVISED.

Issued: MAY, 1977 Revised: OCTOBER, 1977

HOLDEN 'HZ' FEATURES

SPECIFICATIONS

ENGINE DATA

PRINCIPAL COMPONENTS (CONT'D)

ENGINE ELECTRICAL SYSTEM (Cont'd...)

STARTER MOTOR

MAKE BOSCH (ALTERNATIVE LUCAS)
 TYPE 4 POLE 4 BRUSH PRE-ENGAGED DRIVE

NUMBER OF TEETH

PINION 9
 FLYWHEEL
 L6 137
 V8 153

STARTER MOTOR TEST DATA

ENGINE	LOCK TEST CURRENT AMPS. @ 7V	LOCK TORQUE LBS./FT. NM	BRUSH TENSION oz. (kg.)
ALL MODELS	510	19 25.8	42/46 (1.19/1.30)

IGNITION COIL

MAKE BOSCH OR LUCAS
 CURRENT DRAW - AMPS
 RUNNING (IDLING) 3.3
 STOPPED 3.7

SPARK PLUGS

MAKE AC
 TYPE & GAP SETTING - INS (mm)
LOCAL ENGINES (1976 EMISSIONS EQUIPMENT)
 3300 3.3 45 T .040 (1)
 4.2 & 5.0 44 T .040 (1)
EXPORT ENGINES (WITHOUT 1976 EMISSIONS EQUIP)
 2850 44 T .038 (.965)
 3300 45 T .038 (.965)
 4.2 & 5.0 44 T .038 (.965)

ENGINE	CENTRIFUGAL ADVANCE DEGREES @ ENG. RPM			VACUUM ADVANCE DEGREES AT KPa		APPROX. BREAKER GAP INS. (mm)	CAM. ANGLE DEGREES	CONDENSOR CAPACITY MICROFARAD
	START	INTERMEDIATE	FULL	START	FULL			

LOCAL ENGINES (WITH 1976 EMISSIONS EQUIPMENT)

3300 HC M	0/4.0 @ 1000	13/17 @ 1700	23/27 @ 4400	0 @ 13/21	11 @ 37 TO 15 @ 30	.018 (.45)	30/34	.15/.20
3300 LC M	0/2.0 @ 1100	22/26 @ 2000	33/37 @ 4400					
3300 HC A	0/2 @ 1000	14/18 @ 2000	23/27 @ 4400					
3300 CHASSIS CAB	0/1.4 @ 1200	9.4/13.4 @ 2000	26/30 @ 4400	5/9 0 @ (127/229)	10 @ 110 TO 14 @ 96			
4.2	0/2 @ 750	16/20 @ 2500	27/31 @ 4400	0 @ 15/25	14 @ 40 TO 18 @ 35	.016 (.41)	26/30	
5.0			22/26 @ 4400	0 @ 20/30	14 @ 47 TO 18 @ 37			

EXPORT ENGINES (LESS 1976 EMISSIONS EQUIPMENT)

2850	0/2 @ 600	20/24 @ 2000	31/35 @ 4600	5/7 0 @ (127/178)	11 @ 69 TO 15 @ 59	.022 (.56)	30/35	.15/.20
3300					9 @ 76 TO 13 @ 62			
4.2	0/2 @ 500	17/21 @ 2000 15/19 @ 2000	28/32 @ 4400 22/26 @ 4000	4/8 0 @ (152/203)	14 @ 96 TO 18 @ 83	.014 (.36)	30/34	
5.0								

TIMING SPARK ADVANCE INITIAL SETTING DEG. BTDC/RPM
 LOCAL ENGINES (WITH 1976 EMISSIONS EQUIPMENT)
 3300 6° BELOW 900
 3300 CHASSIS CAB 3° BELOW 900
 4.2 & 5.0 12° at 1350

EXPORT ENGINES (LESS 1976 EMISSIONS EQUIPMENT)
 L6 8° @ 800
 V8 4.2 LC 8° @ 800
 4.2 HC MAN. 10° @ 800
 4.2 HC AUTO. 12° 800
 5.0 6° 800

TIMING MARK

L6, V8 - TDC LONG MARK ON TIMING COVER AND MARK ON HARMONIC BALANCER PULLEY

Issued: MAY, 1977 Revised: JULY, 1978

HOLDEN 'HZ' FEATURES

SPECIFICATIONS

CLUTCH AND TRANSMISSION

CLUTCH AND CONTROLS

CLUTCH				
TYPE SINGLE DRY PLATE
SPRINGS				
TYPE BELLVILLE DIAPHRAGM
LINING MATERIAL ASBESTOS FABRIC

DRIVEN PLATE SPECIFICATIONS

ENGINE	OUTSIDE DIA.		INSIDE DIA.		THICKNESS		AREA GROSS (2 LININGS)	
	INS.	MM.	INS.	MM.	INS.	MM.	SQ. INS.	SQ. CM.
6 CYL.	8.62	218.95	6.12	155.45	.298	7.57	157.88	373.4
4.2 V8	9.50	241.30	6.00	152.40			85.22	549.80
5.0 V8	10.00	254.00	6.50	165.10			90.71	581.71

CLUTCH OPERATION SYSTEM

.. .. . CABLE

BEARING THROWOUT

TYPE SINGLE ROW BALL

MANUAL TRANSMISSION

TRANSMISSION TYPE ALL SYNCHROMESH

SHIFT LOCATION

3 SPEED COLUMN

4 SPEED FLOOR

CENTRE DISTANCE INS.(MM) 2.75 (69.8)

GEAR RATIOS :1

TRANSMISSION	OPTION CODE	FIRST	SECOND	THIRD	FOURTH	REVERSE
3 SPEED	M15	3.07	1.68	1.00	-	3.59
4 SPEED	M20	3.05	2.19	1.51	1.00	3.05
	M21	2.54	1.83	1.38	1.00	2.54
	M22	3.74	2.68	1.68	1.00	3.72

OIL CAPACITY AND OIL TYPE

3 AND 4 SPEED 3.4 PINTS (2.0 LITRE) - HN 1046

Issued: MAY, 1977

Revised: